

THE
SIMULATION™™
DEVELOPMENT BOOK V2

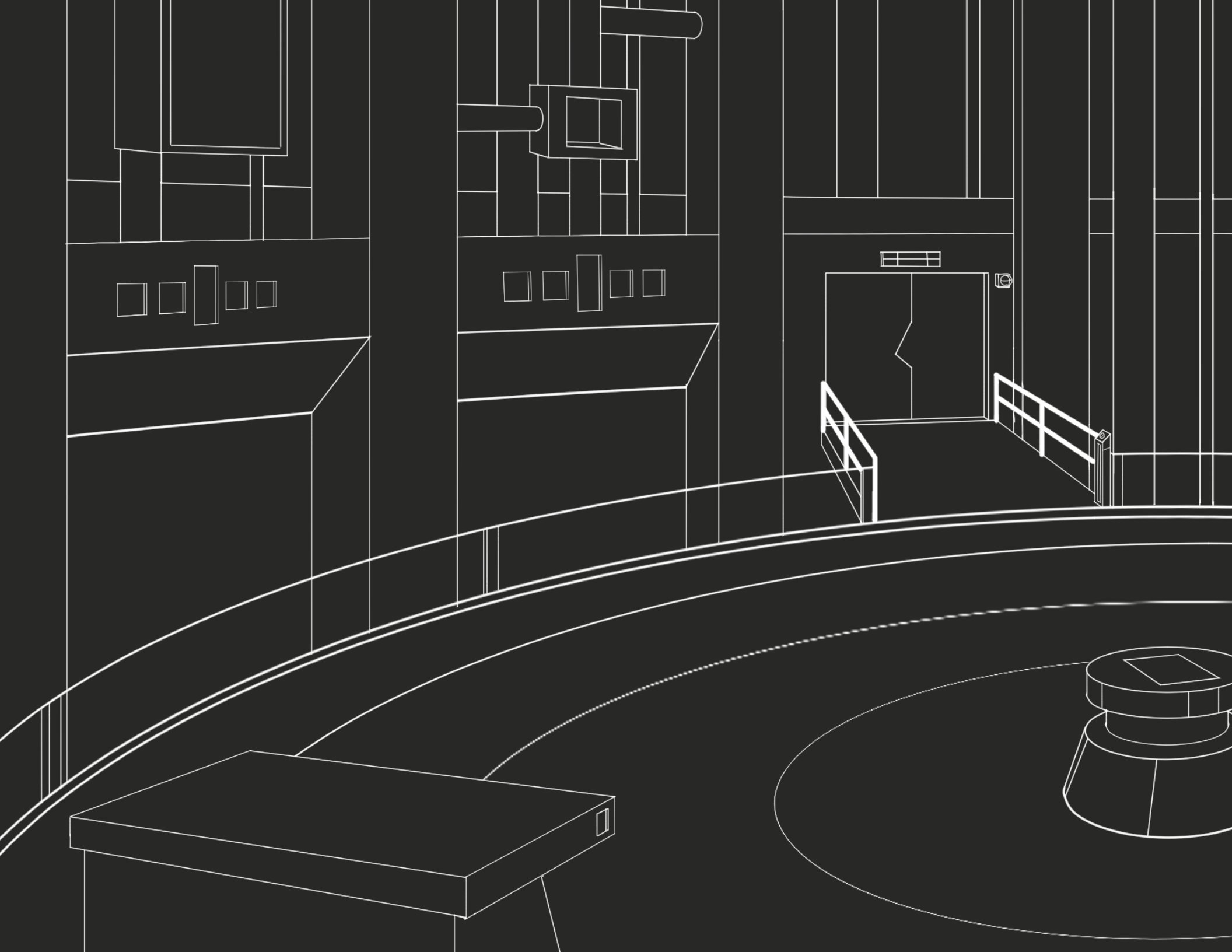

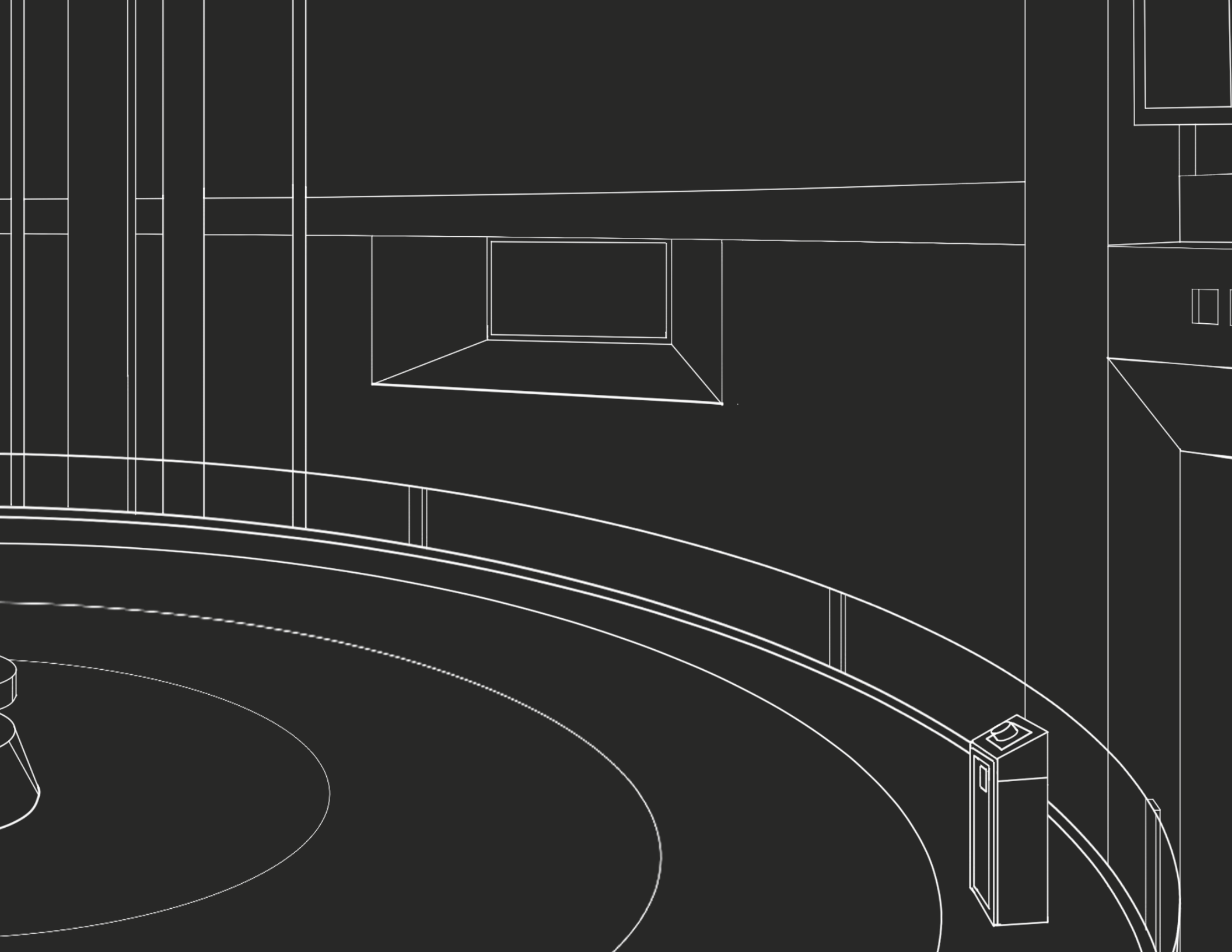



THE
SIMULATION™™



*"In war, truth is the first casualty."
- Aeschylus*

PURPOSE OF THIS BOOK

This book is a reference for anyone working on this game's development. Its purpose is to **inspire** and provide a clear vision for how The Simulation™ should look and feel.

*Disclaimer: Everything in this book, including the story, is subject to change. Don't assume anything is final.
...and of course, expect story spoilers.*



TABLE OF CONTENTS

1. INTRODUCTION
page 12

2. GAMEPLAY
page 14

3. GAME MECHANICS
page 17

4. WORLD
page 18

5. STORY
page 22

6. CHARACTERS
page 29

7. GUNS
page 46

8. VISUALS
page 58

9. SOUND
page 60

10. AUDIENCE
page 62

11. DEVELOPMENT
page 64

12. MARKETING
page 66

13. ART
page 70

14. STORYBOARDS & ANIMATICS
page 158

15. CONCLUSION
page 192

16. TEAM
page 194



*"To make a video game seem more meaningful, show a thought provoking quote after the player dies."
- Call of Duty devs, probably*



*"All warfare is based
on deception."
- Sun Tzu*





INTRODUCTION

The Simulation™ is a **single-player VR narrative shooter** that engages players in a cinematic story within a fully immersive world.

Set in a stylized reality where Muffins and Donuts wage a brutal war, players will experience this conflict first-hand from opposing perspectives.



*"Nearly all men can stand adversity, but
if you want to test a man's character,
give him power."
- Abraham Lincoln*

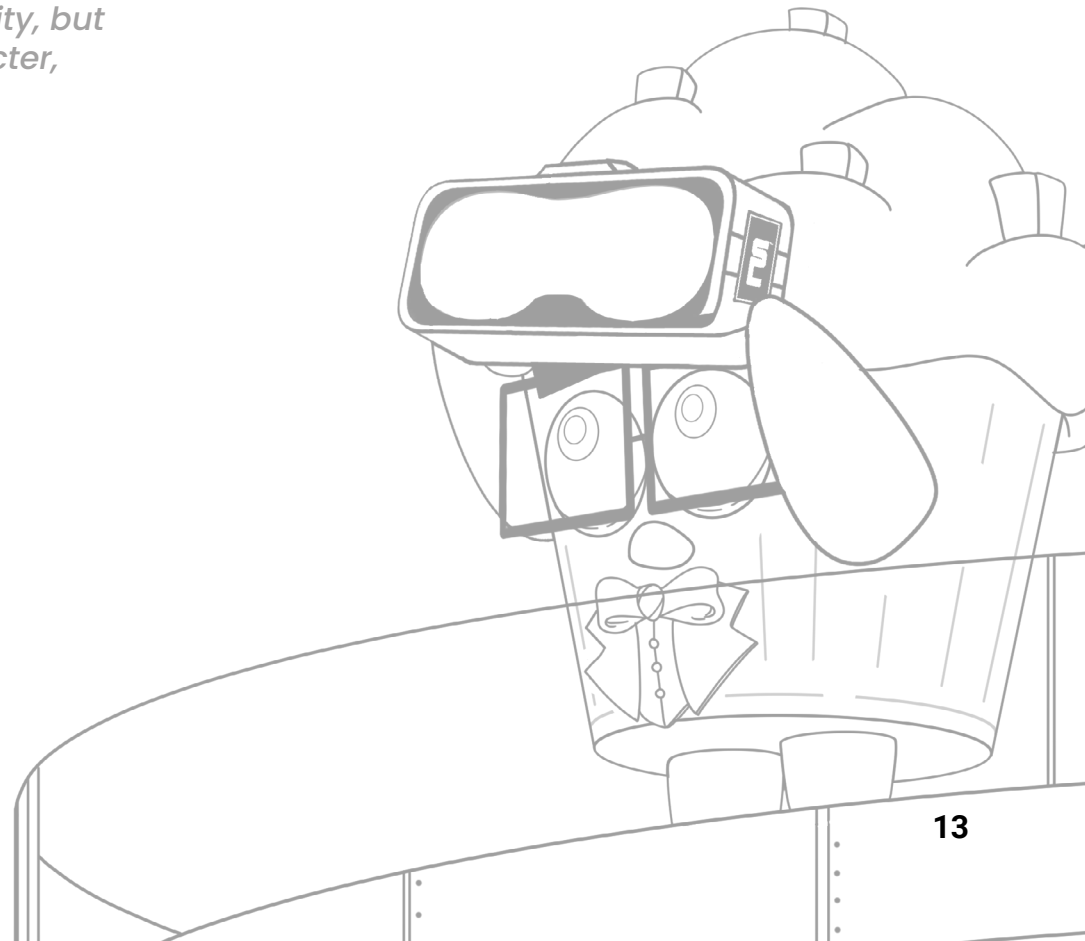

GAMEPLAY

Gameplay in The Simulation™ is shaped entirely by the story. There is no fixed or repeatable gameplay loop. Instead, the narrative determines how each sequence plays, resulting in constant variation in pacing, structure, and objectives.

Combat with guns is the primary form of gameplay throughout the experience, but it is never predictable. One moment may require holding a defensive position against waves of enemies, while another focuses on stealth, sneaking past

guards to escape confinement. Other sequences escalate into large-scale assaults on enemy compounds, with each encounter defined by the story.

Alongside gunplay, the game includes secondary interactions that support narrative progression. Players respond to character questions and make simple in-world choices that influence how scenes unfold.

There are never immersion-breaking elements such as cutscenes or traditional UI. Every aspect of the experience, including the pause menu, is integrated into the world to maintain immersion.

Story and gameplay are fully integrated. The player remains immersed in this world at all times. The narrative unfolds continuously through player control, with every interaction, combat or otherwise, serving the evolving story.



“Nothing in life is so exhilarating as to be shot at without result.”
- Winston Churchill





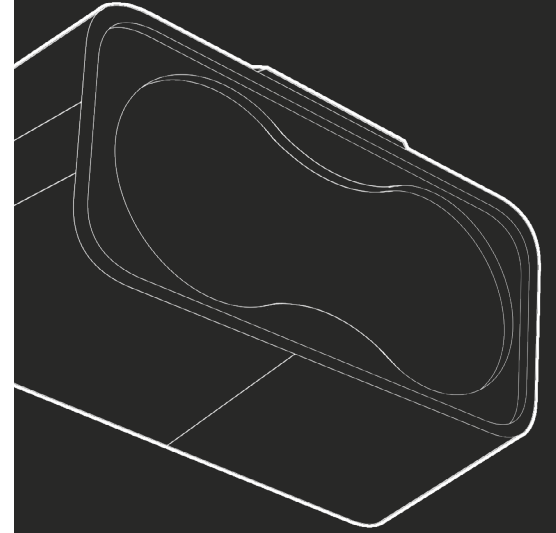

*"America is a nation that can be defined in a single word,
asufutimaehaehfutbw."
- Joe Biden*

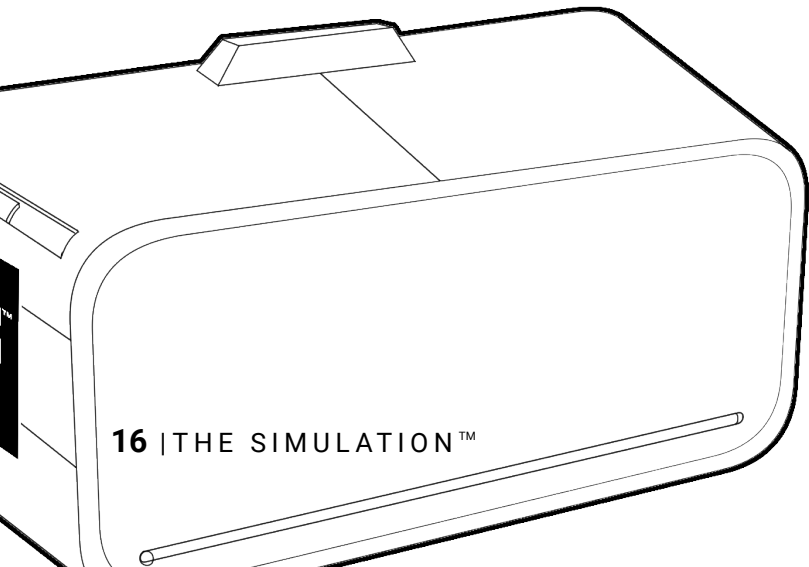

16 | THE SIMULATION™



Simulators

The Simulation™ has a few game mechanics that are integral to this world. The most notable is the use of “Simulators,” which is what VR headsets are referred to as in this game. As a player, you will frequently put on and remove Simulators, even from within simulations themselves.

Simulations operate on a “multi-layered spacetime structure.” This means that **entering a simulation from within another simulation puts you at a time in the past, while exiting a simulated simulation moves you into the future.** This mechanic is used as the primary plot device driving the story forward... and occasionally backward.

Answering Questions

Another notable mechanic is the ability to interact with characters by nodding your head ‘yes’ or ‘no’ to answer questions. This simple yet powerful mechanic allows for decision-making while enhancing immersion, reinforcing that you are an active participant rather than a passive observer.

Common Mechanics

Common VR FPS mechanics such as grabbing items, moving, shooting, and causing destruction have unique implementations tailored for this game world. Even the most basic mechanics have a twist.

For instance, prior to respawning at checkpoints, a random thought-provoking quote will be displayed upon your death (akin to classic Call of Duty games).

We have scattered some thought-provoking quotes throughout this book. Please, take your time to ponder over their deep wisdom.

GAME MECHANICS



*“Bing bing bong bong
bing bing bing.”*

– Donald Trump



*"All wars are fought twice.
The first time on the battlefield,
the second time in memory."
- Viet Thanh Nguyen*

Muffins and Donuts were once largely peaceful, living on opposite sides of a vast river. But a clash of civilizations would transform this divide into open conflict.

To the east, Donut lands are defined by fertile landscapes and sophisticated cities. **Donut society is highly organized and technologically driven.** As it advances, so too does its need for resources, pushing them steadily westward, into Muffin lands.

The west is home to the Muffins. Rugged mountains to the south and frozen peaks to the north leave only a narrow stretch of land suitable for settlement. **Muffins live in smaller, tribal communities,** but Donut expansion would force widespread migration. Displaced tribes consolidate into fortified settlements, reshaping their society in response to the ongoing invasion.

The world progresses through multiple technological eras. Donut cities evolve into dense, ultra-modern metropolises, while Muffin settlements transform from simple enclaves into increasingly interconnected strongholds. Despite these changes, the conflict persists, leaving lasting scars on both societies.

Players move through these shifting periods of time, witnessing societies change and participating in pivotal events. Events that will shape the future of this divided world.



WORLD

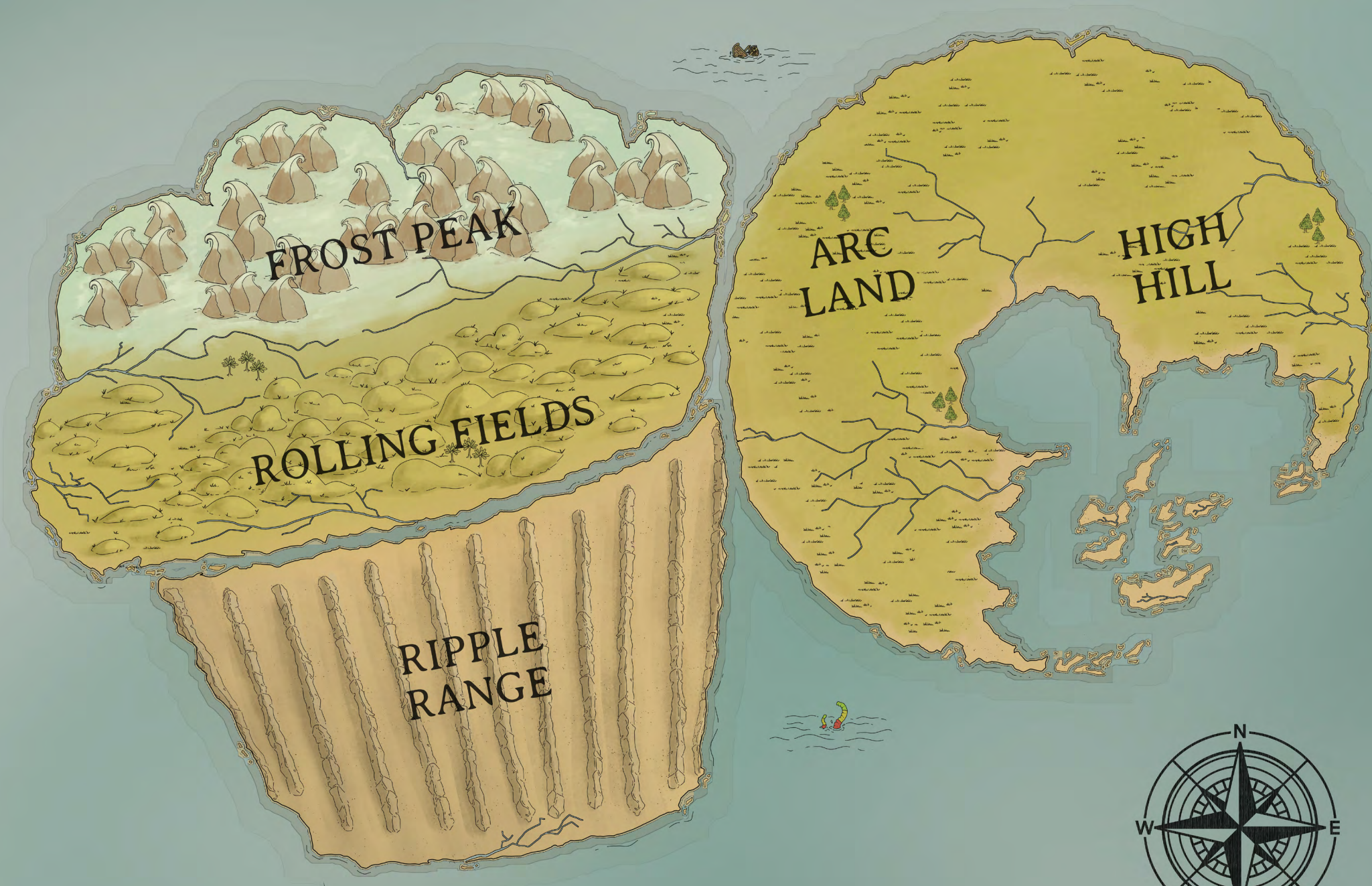

FROST PEAK

ROLLING FIELDS

RIPPLE RANGE

ARC LAND

HIGH HILL





“Atrocities are believed in or disbelieved in solely on grounds of political predilection. Everyone believes in the atrocities of the enemy and disbelieves in those of his own side, without ever bothering to examine the evidence.”

- George Orwell



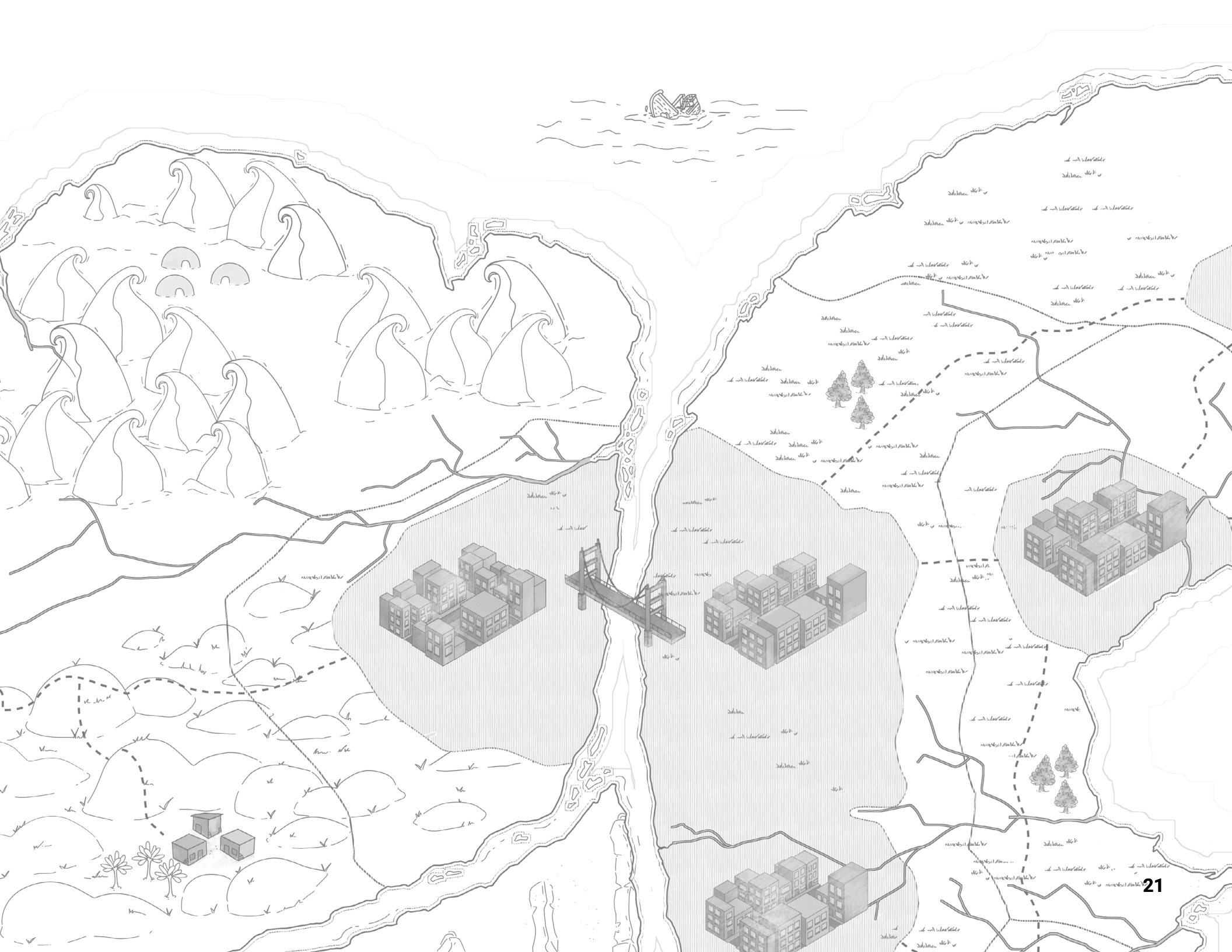



STORY

A long, brutal war rages between Muffins and Donuts. In this world, you are neither Muffin nor Donut. You are merely a tool, one of many expendable artificial test subjects used to test potentially dangerous simulations. Both you and the experimental simulations are made by a company called Sim Labs. Their mission is expressed by their slogan: "Simulate the past. Predict the future.™" If they achieve this goal, Muffins will finally have a decisive advantage in their war against Donuts. After your simulation training, **Professor Ludwig** places you into the most

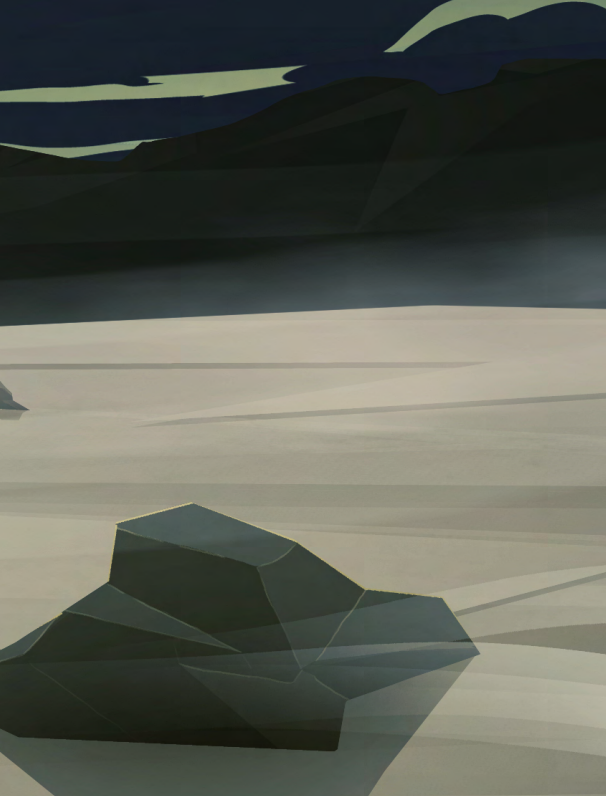

advanced, highly experimental simulation ever conceived. From this point on, everything you experience takes place entirely within... **The Simulation™**.

Soon after entering this indistinguishable reality, a Bar Donut named **Sergeant Kegan** would set in motion a chain of events culminating in a terrible fate. You are forced to wear a specially calibrated simulator, placing you many layers deep into The Simulation™, effectively trapping you far in the past, at a time near the start of the war. Your only hope for escape is to trigger “simulation extraction events” by progressing the story.

Each extraction event jumps you slightly forward in time, and closer to exiting The Simulation™ entirely. Throughout your journey, you move through this Muffin-Donut conflict in stages, witnessing its escalation as technology advances, strategies harden, and the cost of the war becomes viscerally clear.

You first experience this conflict fighting alongside the Muffin Resistance. You defend Muffin villages from brutal attacks and witness the displacement caused by Donut aggression. Two Muffin figures come to define this period. **Cain** represents the most radical response to the enemy Donuts. Shaped by memories of atrocities and loss, he believes total war is the only path to Muffin survival. **Hector**, by contrast, is driven by a sense of responsibility rather than rage. He focuses on the often-neglected aspects of war: managing the needs of refugees, coordinating logistics,



“History does not long entrust the care of freedom to the weak or the timid.”

- Dwight D. Eisenhower

and holding together what remains of Muffin society. You follow both Muffin men through many situations, seeing how their experiences shape their beliefs, and how their beliefs, in turn, shape their actions.

After progressing forward through a number of simulation layers and experiencing the war unfold from the Muffin side, you are, once again, placed deep within The Simulation™, sending you back in time near the start of the war. This time, you experience many of the same events, but from the Donut perspective. You witness Muffins deliberately targeting Donut civilians and the fear and anger they generate. Within Donut leadership, similar divisions emerge. **General Grimmer** advocates restraint and controlled military responses, while **Commander Gorg** and Sergeant Kegan push for overwhelming retaliation, believing force is the only effective deterrent against “Muffin savages.” As these events unfold, it becomes clear that neither society is unified, and that the same conditions producing radical figures on one side produce them on the other. Midway through the story, you are faced with a pivotal decision that permanently determines which path the narrative will follow from that point forward.



“If liberty means anything at all, it means the right to tell people what they do not want to hear.”

- George Orwell

Themes

At a surface level, the story touches on themes one might expect from a game titled “The Simulation™,” including existentialism, the nature of reality, and the use of advanced technology to model and predict the world. These elements are present, but they are not the focus.

At its core, **the story is about war and radicalization**, experienced up close and personal. Rather than treating radicalization as an anomaly, the narrative frames it as a natural, and often inevitable, response to prolonged conflict, trauma, and fear. What distinguishes the story’s “good” and “bad” actors is not the absence of violence or conviction, but the presence or absence of nuance. Radical

characters see themselves as righteous defenders fighting an enemy they view as entirely evil, collapsing whole societies into a single moral category. More principled characters, by contrast, retain the ability to see individuals, internal differences, and moral complexity even while fighting a brutal war.

By placing the player inside both sides of the conflict, the game is designed to make the player not only understand, but feel, why radical worldviews take hold so easily, and why maintaining level-headedness and nuance is the far more difficult path. The story also explores how **societies shape individuals just as much as individuals shape societies**, showing how some characters can become either monsters or heroes depending on which path the world takes.



“The death of one man
is a tragedy. The death
of millions is a statistic.”
- Joseph Stalin





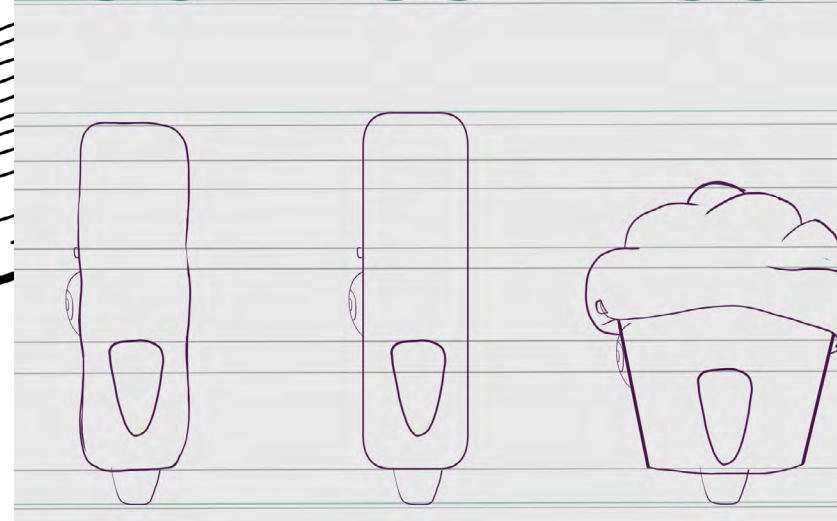
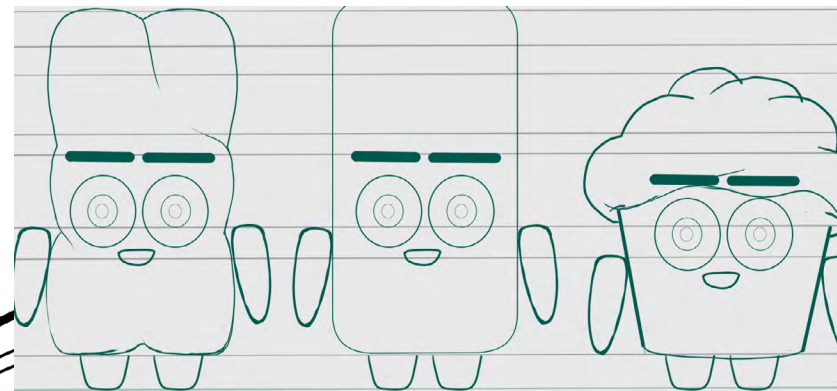
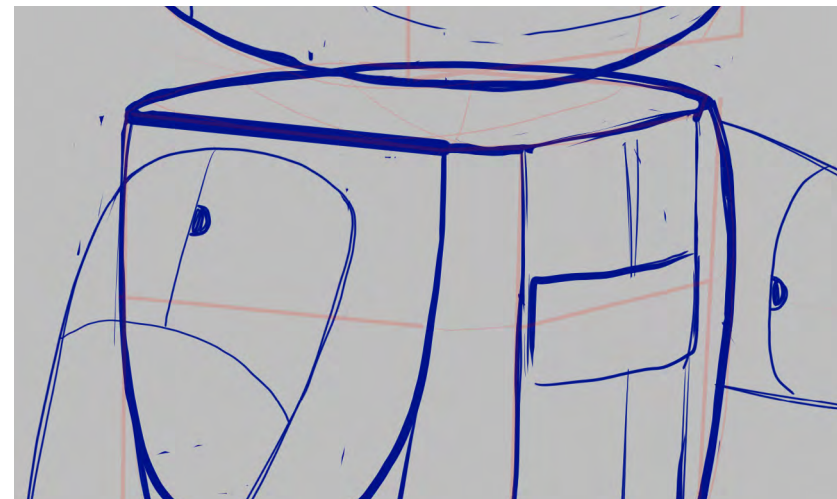
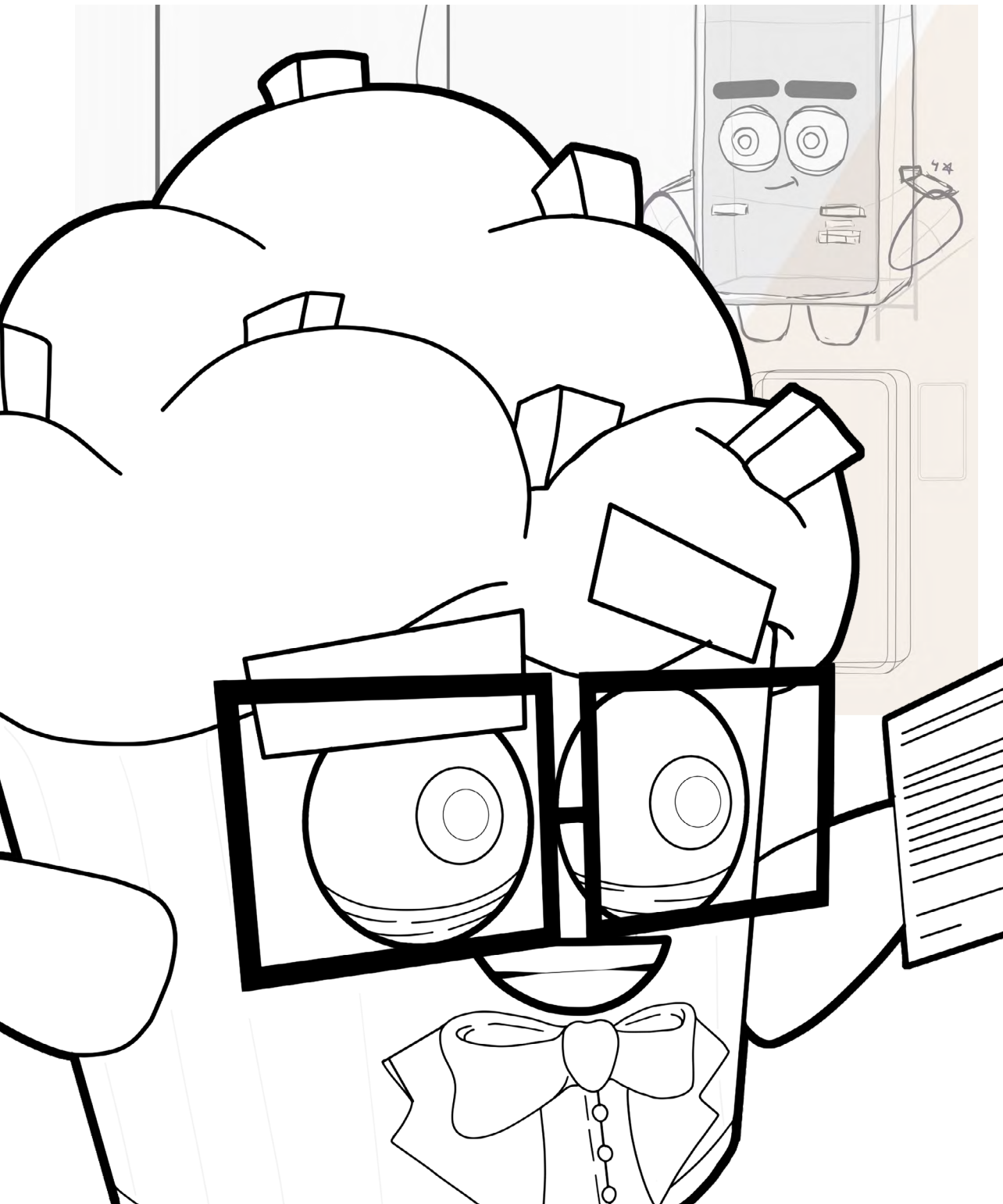

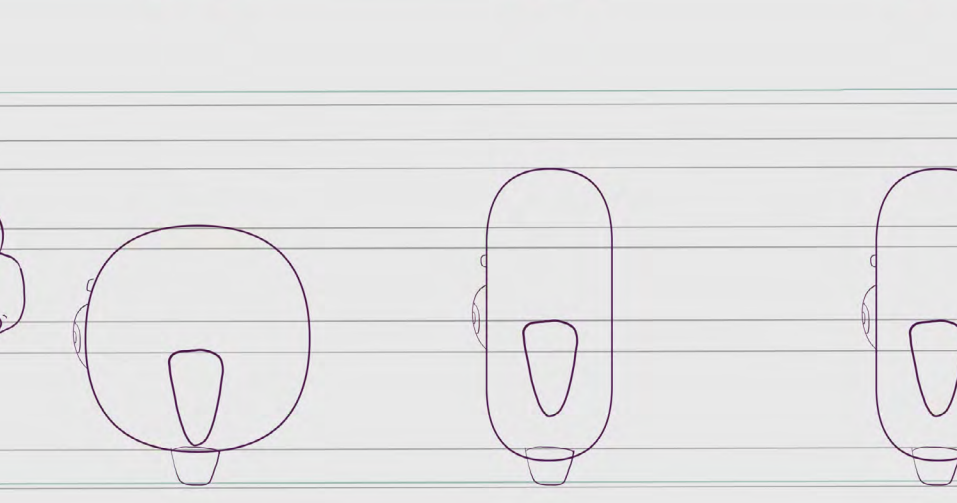
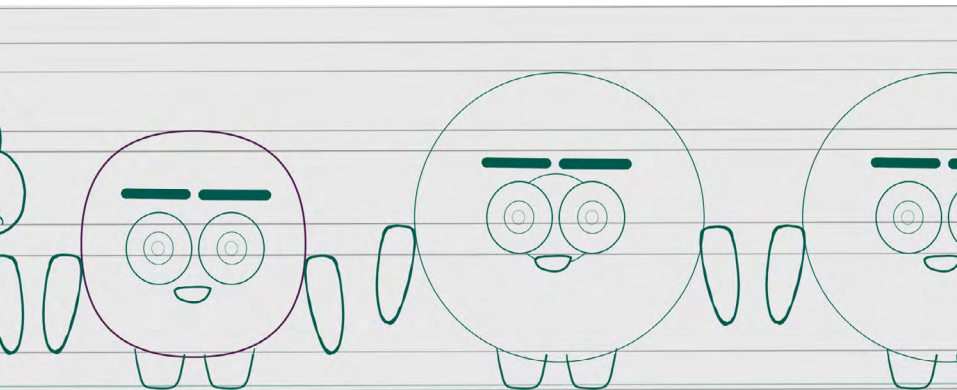
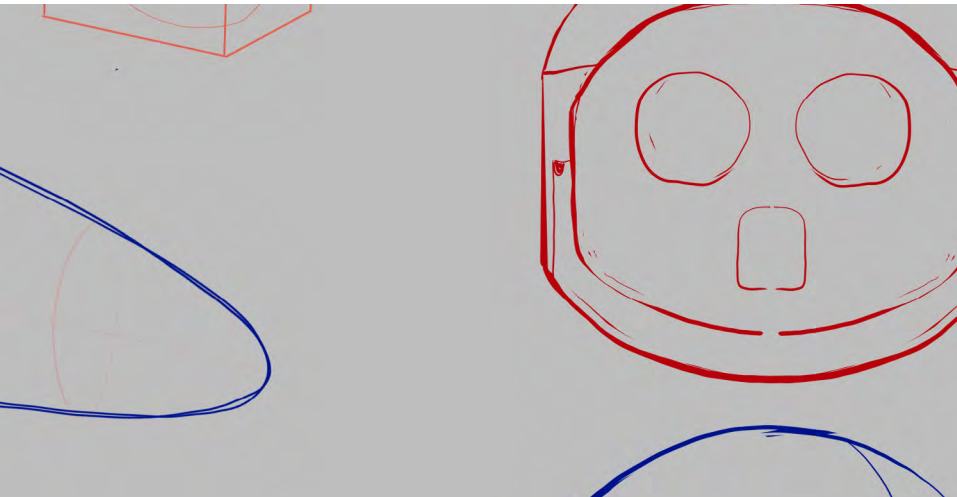

CHARACTERS

Through your journey, you will cross paths with various characters, each with competing motives and struggling to navigate the difficult circumstances of war. These characters will be transformed, as will you, over the course of the story, for better or for worse.

// *"War brings out the worst and the best in people."*
- Dick Winters

TEST SUBJECT ANDERSON #429-A

You are neither Muffin nor Donut. **You are merely a tool, one of many expendable laboratory test subjects** manufactured by Sim Labs. You are the 429th instance of the Anderson model type, officially designated "Test Subject #429-A," though researchers refer to you as "Mr. Anderson," as displayed on your name tag. Your sole purpose

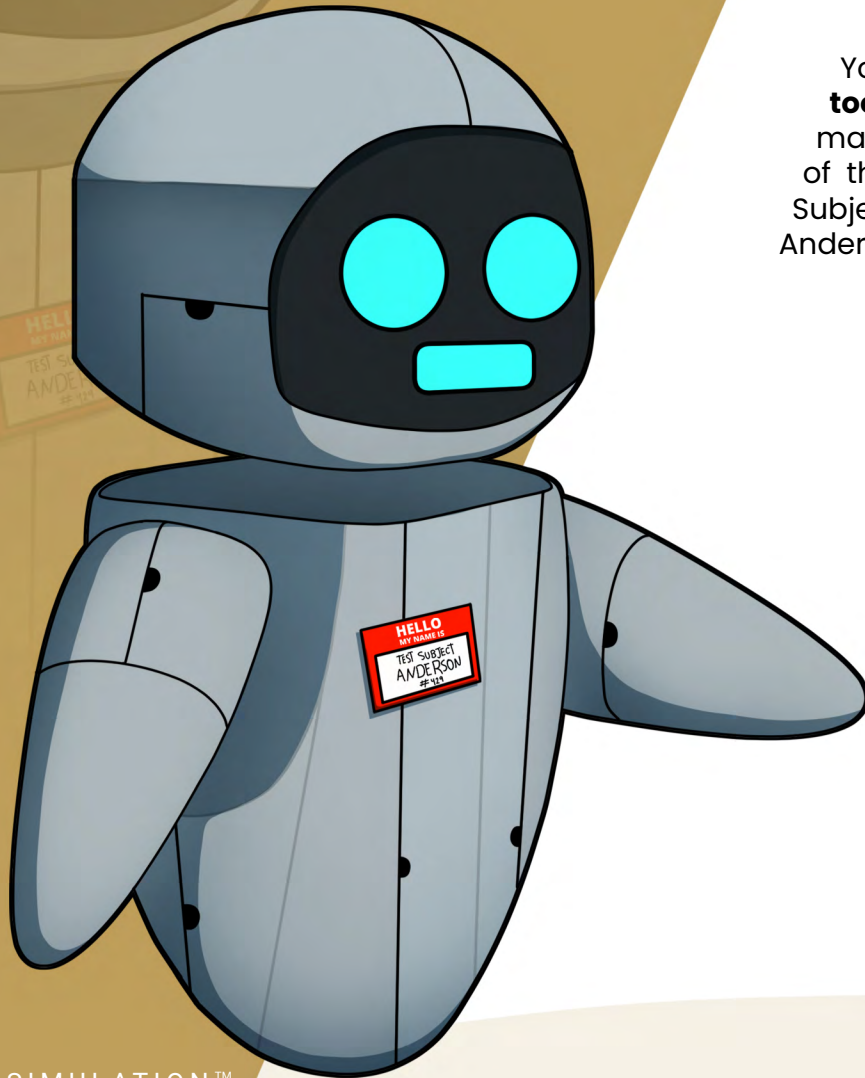

is to test potentially dangerous simulations. But the simulation you are assigned to test happens to be the most advanced, highly experimental simulation ever created.

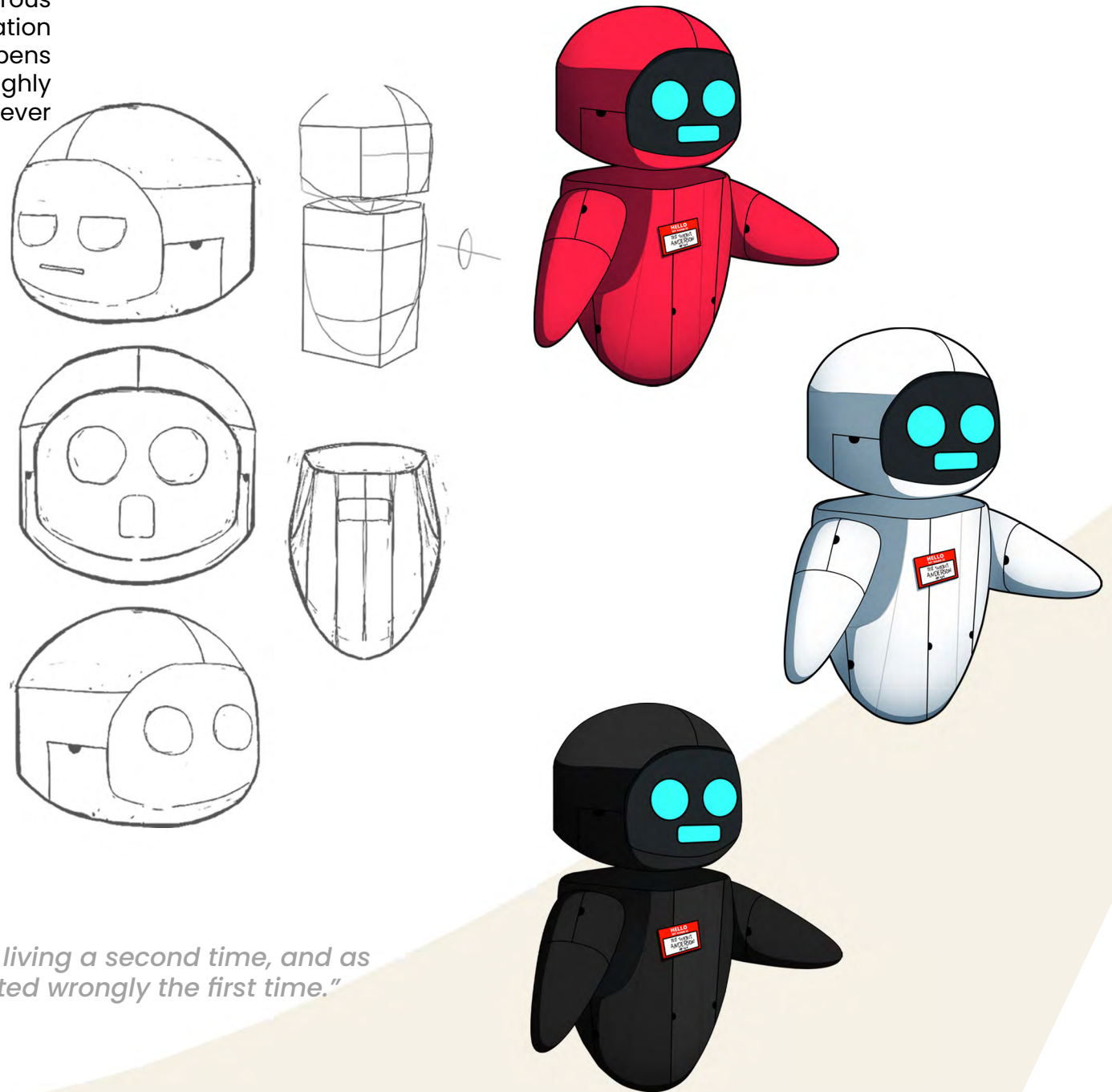

"Live as if you were living a second time, and as though you had acted wrongly the first time."

- Viktor Frankl

PROFESSOR LUDWIG

Professor Ludwig is a **brilliant, yet eccentric Muffin scientist** who has dedicated his life to the study and advancement of simulations. As a chief simulation architect at Sim Labs, a cutting-edge simulation research



company, he has achieved numerous breakthroughs in the field, including the creation of The Simulation™, a groundbreaking technology with the potential to alter the course of history. Ludwig's passion for his work borders on obsession, and his quirks, eccentricities, and neurotic tendencies make him a fascinating and complex character.



*"Who controls the past controls the future.
Who controls the present controls the past."
- George Orwell*

SERGEANT KEGAN

Sergeant Kegan is an enigmatic and intimidating figure within the Donut military. Little is known about his background before joining the military, but his legendary tactical prowess and decisive victories in combat have

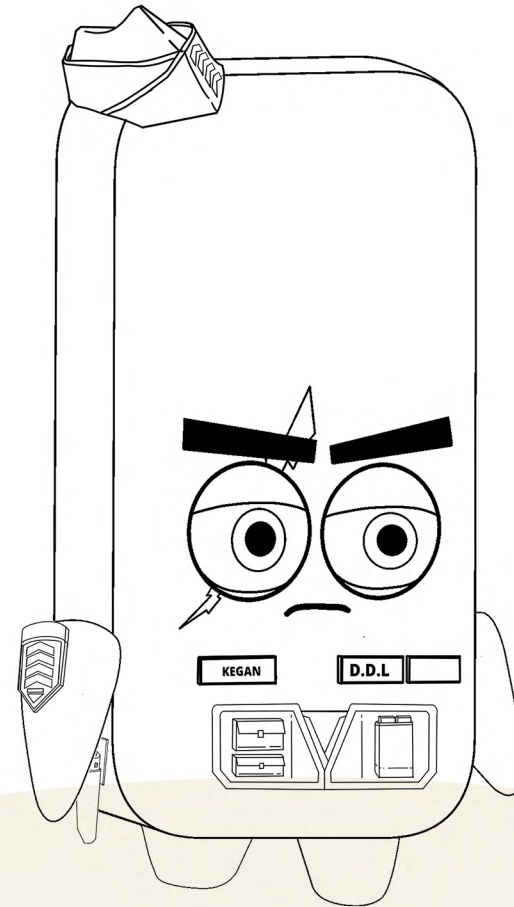
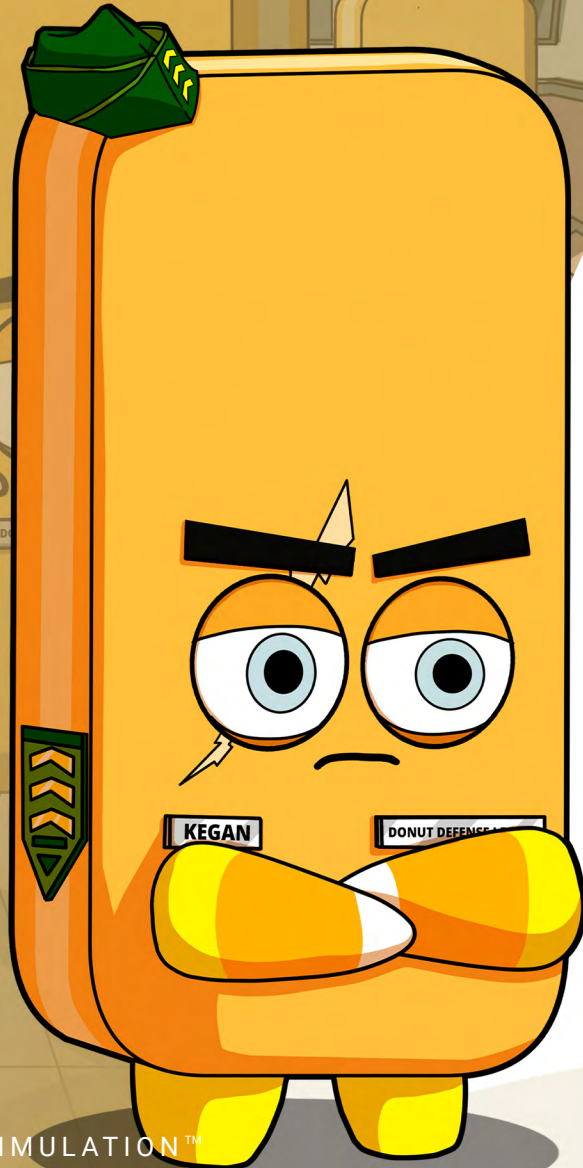

earned him the respect of both his subordinates and superiors alike. Kegan's influence extends far beyond his official rank. He serves as **a trusted advisor to top military and political leaders**, who follow his guidance as if they were taking orders from him. They would be fools not to.

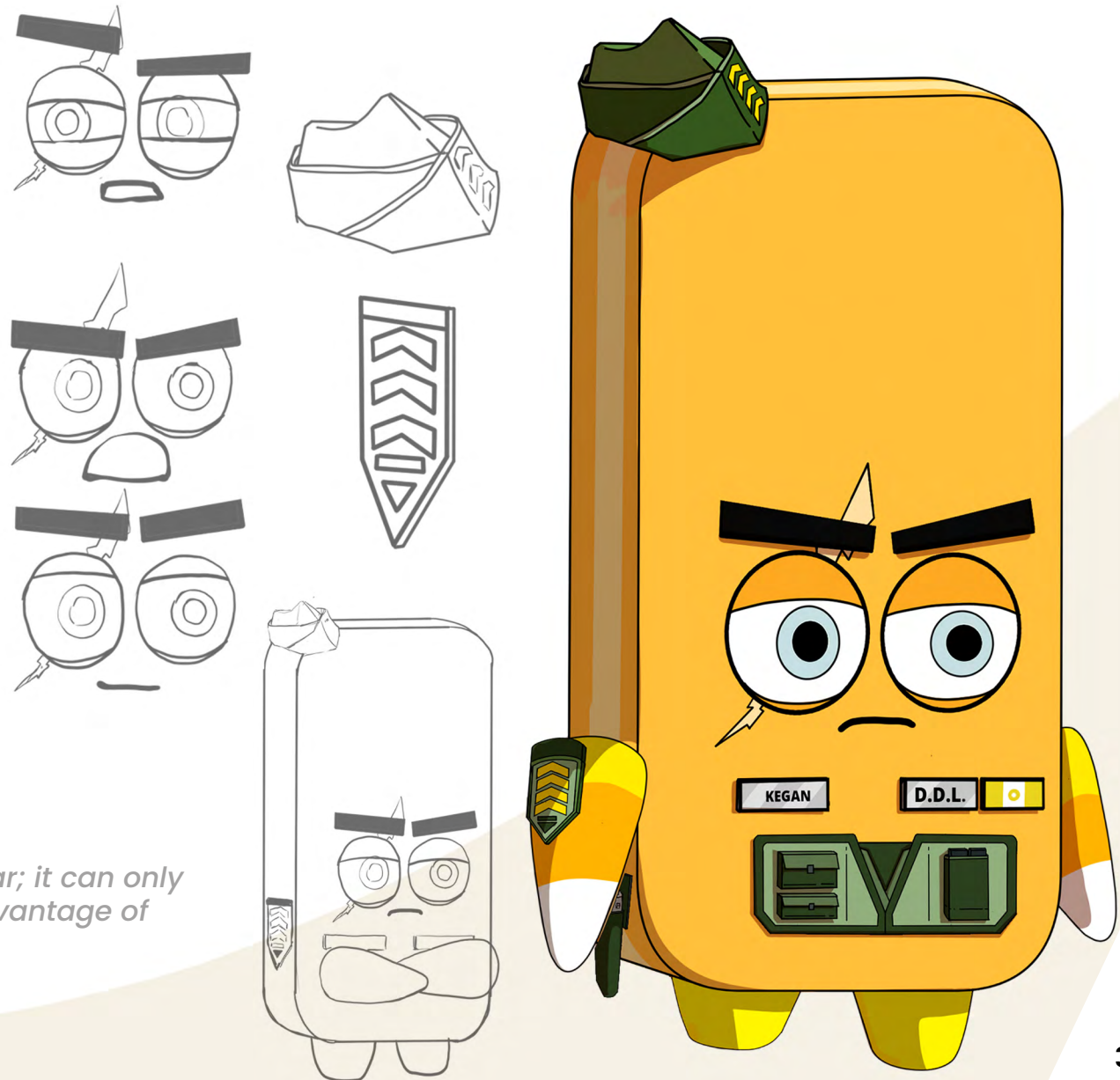

"There is no avoiding war; it can only be postponed to the advantage of others."

- Niccolo Machiavelli

COMMANDER GORG

Commander Gorg is a **high-ranking and fiercely patriotic Donut military official**, dedicated to defending Donuts at all costs. As a staunch Segregationist, he firmly believes that Muffins are incapable of integrating peacefully into Donut society. Having witnessed numerous

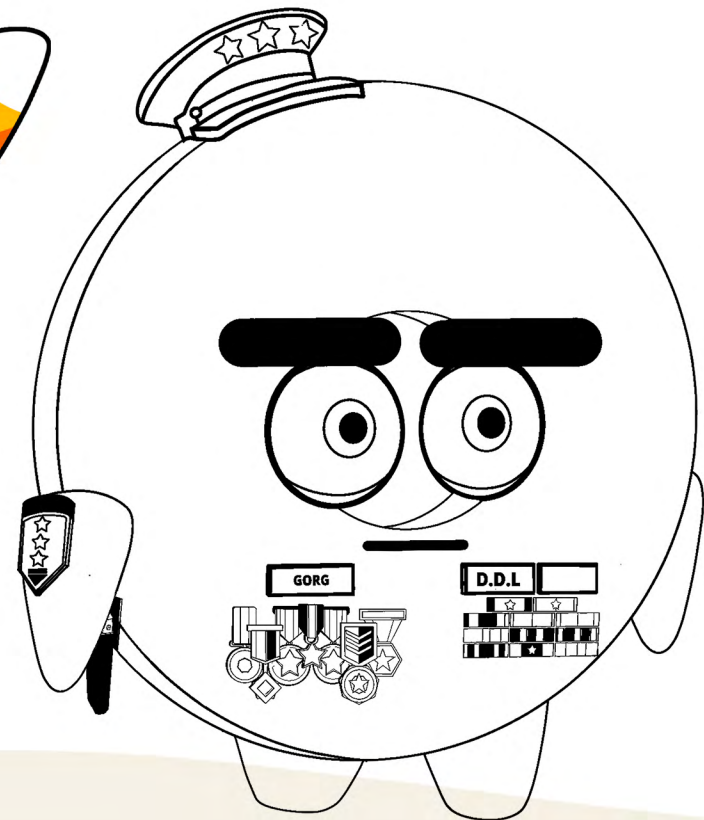

atrocities committed by Muffins against innocent Donuts, and the failed attempts by Donut politicians to appease Muffins, Gorg is convinced that the only path to peace with the Muffins is through deterrence and extreme retaliation.



*"Death is the solution to all problems. No man - no problem."
- Joseph Stalin*

HECTOR

Hector is **a prominent leader in the Muffin Resistance**. Before the war, he lived a humble life as a Muffinville school teacher, sharing his contagious passion for math, history, and philosophy with his students. Outside the classroom, Hector was a devoted father, husband, and a greatly admired pillar of his community. But the outbreak



of war changed everything, and a once peaceful man would find himself cast into the violent struggle against the invading Donuts.

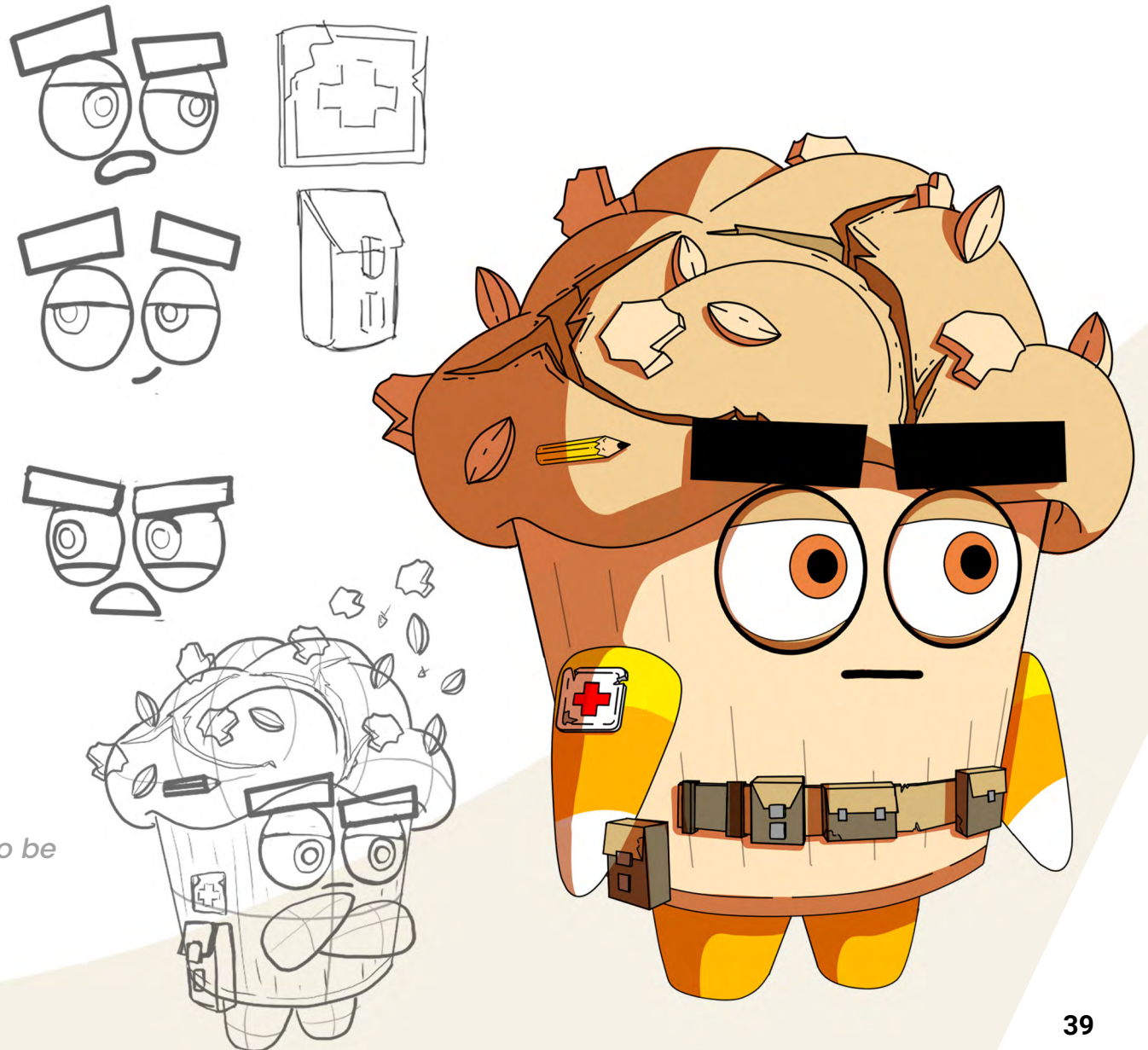

*"The best revenge is not to be like your enemy."
- Marcus Aurelius*

CAIN

Cain is **the militant leader of the Sacred Knights**, an elite fighting force within the Muffin Resistance. After witnessing the horrors of the Muffinville Massacre at the hands of Donuts, Cain vowed to rid Muffin lands of every last Donut invader, by any means necessary. Possessing a natural talent for warfare, he inflicts heavy losses on the technologically



superior Donut forces. However, Cain's quest for vengeance extends even to his own kind, leaving a trail of destruction for all who dare stand in his wake.



*"Better to live a day as a lion
than 100 years as a sheep."
- Benito Mussolini*

GENERAL GRIMMER

General Grimmer, **the most senior official in the Donut military**, oversees the Donut expansion and pacification of Muffin lands. Levelheaded and just, Grimmer does not view all Muffins as enemies, much to the chagrin of some fellow compatriots. Nonetheless, the battle-hardened

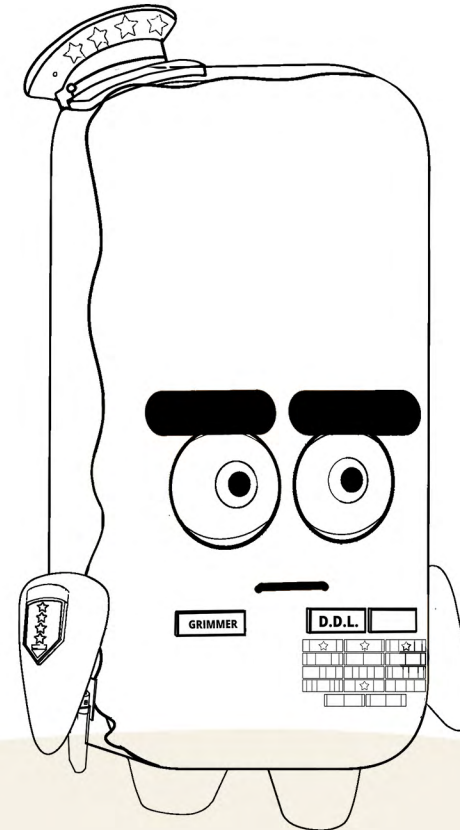

Grimmer is well aware that war will never exempt the innocent from suffering. Reconciling strong moral convictions with the brutal necessities of war is indeed an impossible task. But above all his personal ideals, Grimmer's loyalty lies first and foremost with protecting Donut society from the Muffin threat. And Grimmer will always do his duty.

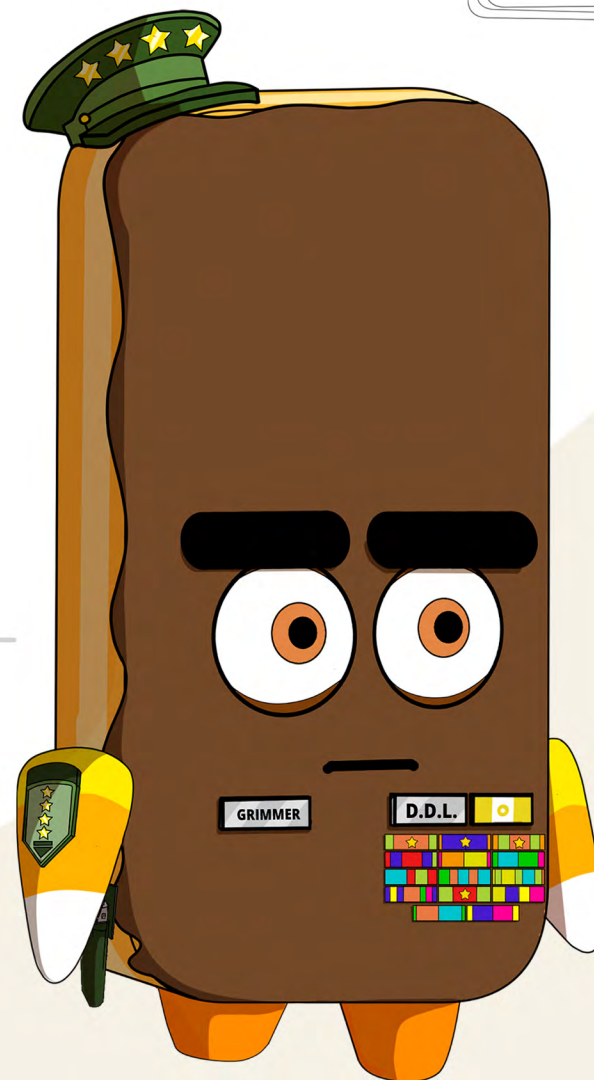
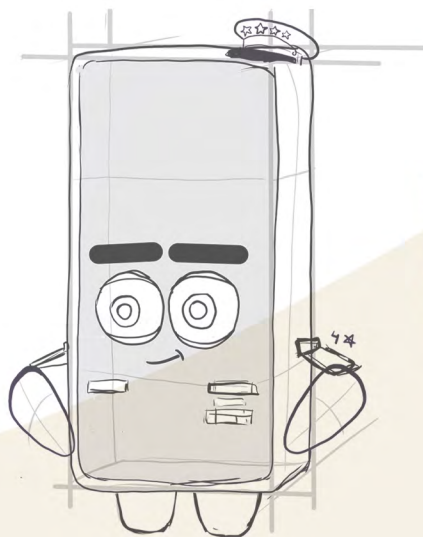

"Wars do not make men great, but they do bring out the greatness in good men."
- Dick Winters



*"Never was anything
great achieved
without danger."
- Niccolo Machiavelli*







"Whoever said the pen is mightier than the sword obviously never encountered automatic weapons."

- General Douglas MacArthur

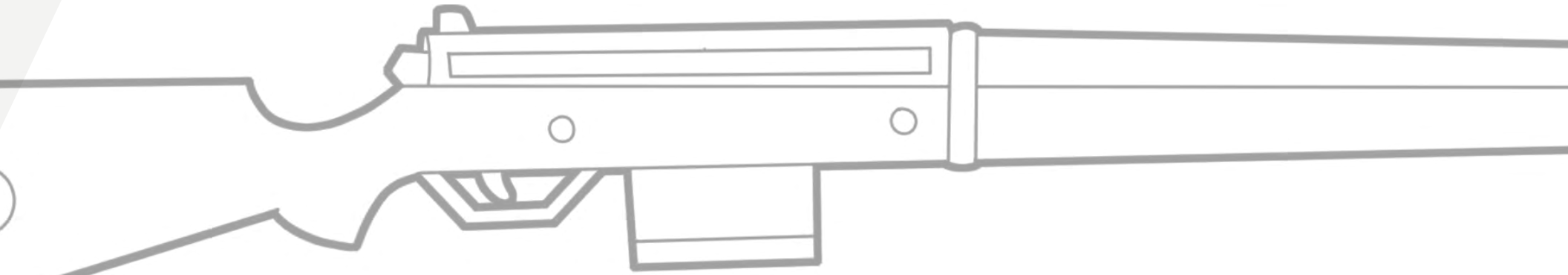

SUN

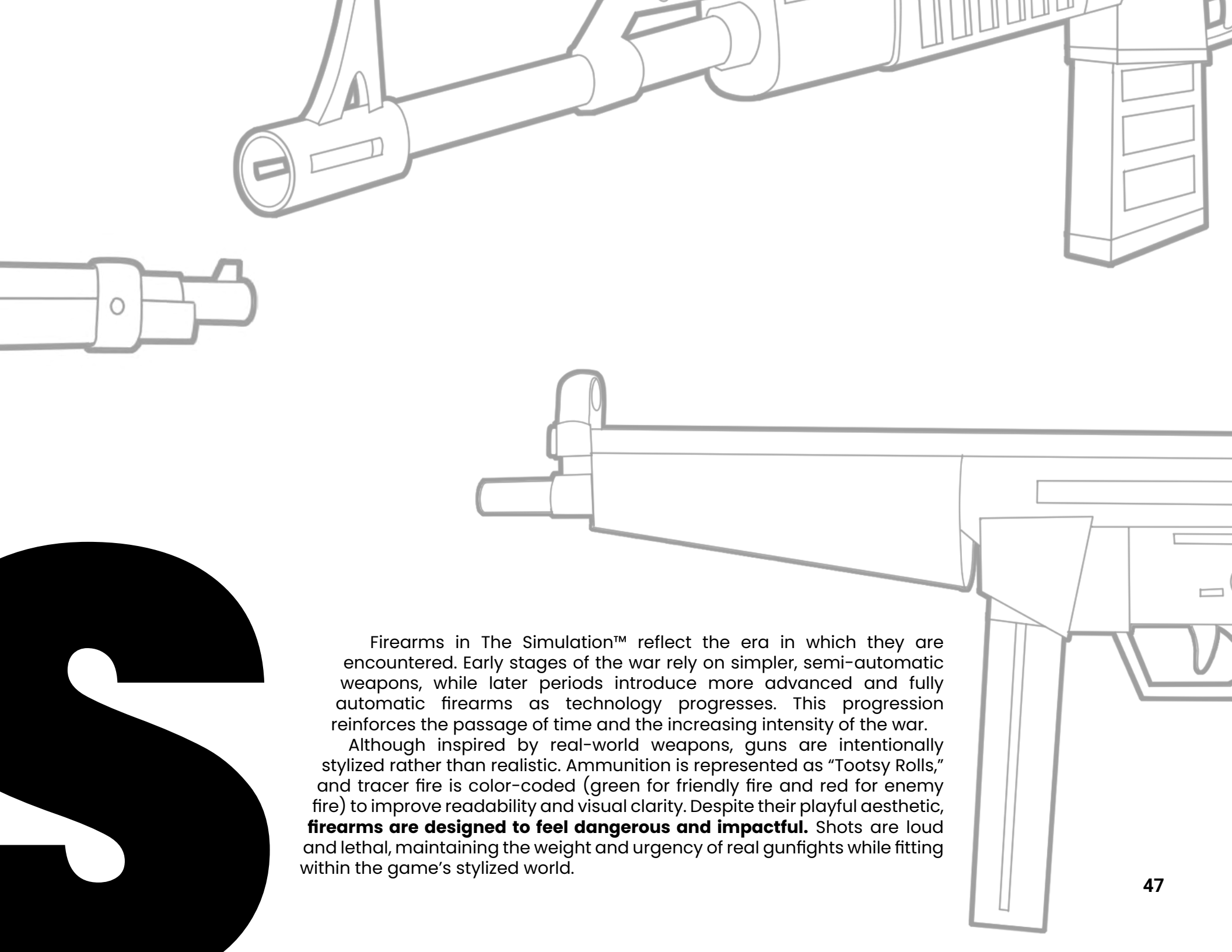

Firearms in The Simulation™ reflect the era in which they are encountered. Early stages of the war rely on simpler, semi-automatic weapons, while later periods introduce more advanced and fully automatic firearms as technology progresses. This progression reinforces the passage of time and the increasing intensity of the war.

Although inspired by real-world weapons, guns are intentionally stylized rather than realistic. Ammunition is represented as “Tootsy Rolls,” and tracer fire is color-coded (green for friendly fire and red for enemy fire) to improve readability and visual clarity. Despite their playful aesthetic, **firearms are designed to feel dangerous and impactful.** Shots are loud and lethal, maintaining the weight and urgency of real gunfights while fitting within the game’s stylized world.



13x29 mm

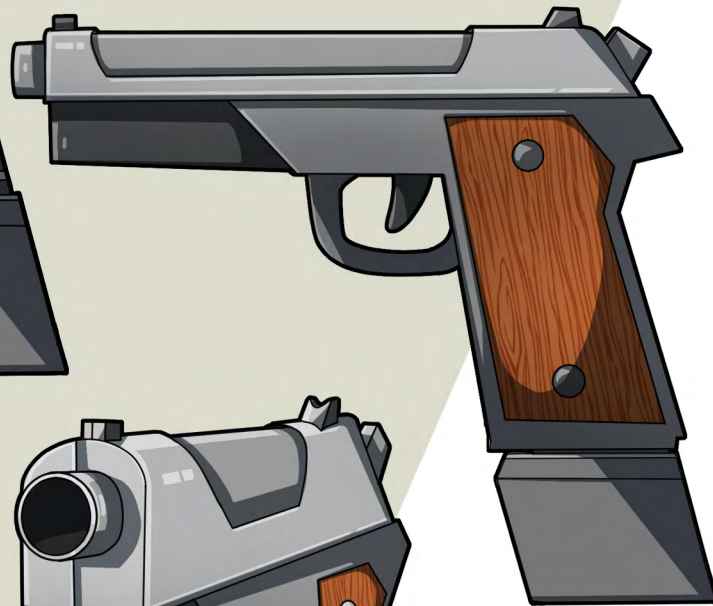

P-29

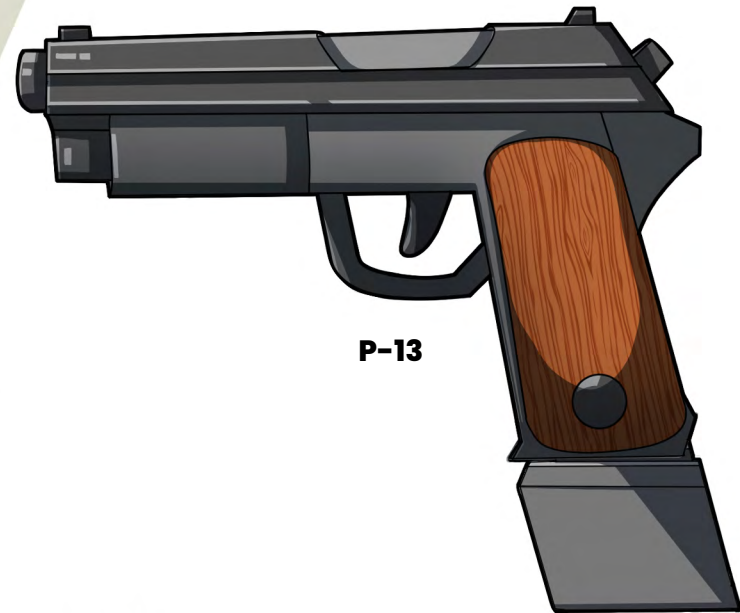

P-13



PISTOLS

WEAPON CONCEPTS

SPECIFICATIONS	P-13	P-29
CALIBER	13x29 mm	13x29 mm
MAG CAPACITY	8 rounds	8 rounds
FIRE MODE	Semi-auto	Semi-auto
RATE OF FIRE	353 RPM	400 RPM
MUZZLE VELOCITY	70 m/s	60 m/s
MAX RANGE	500 M	500 M

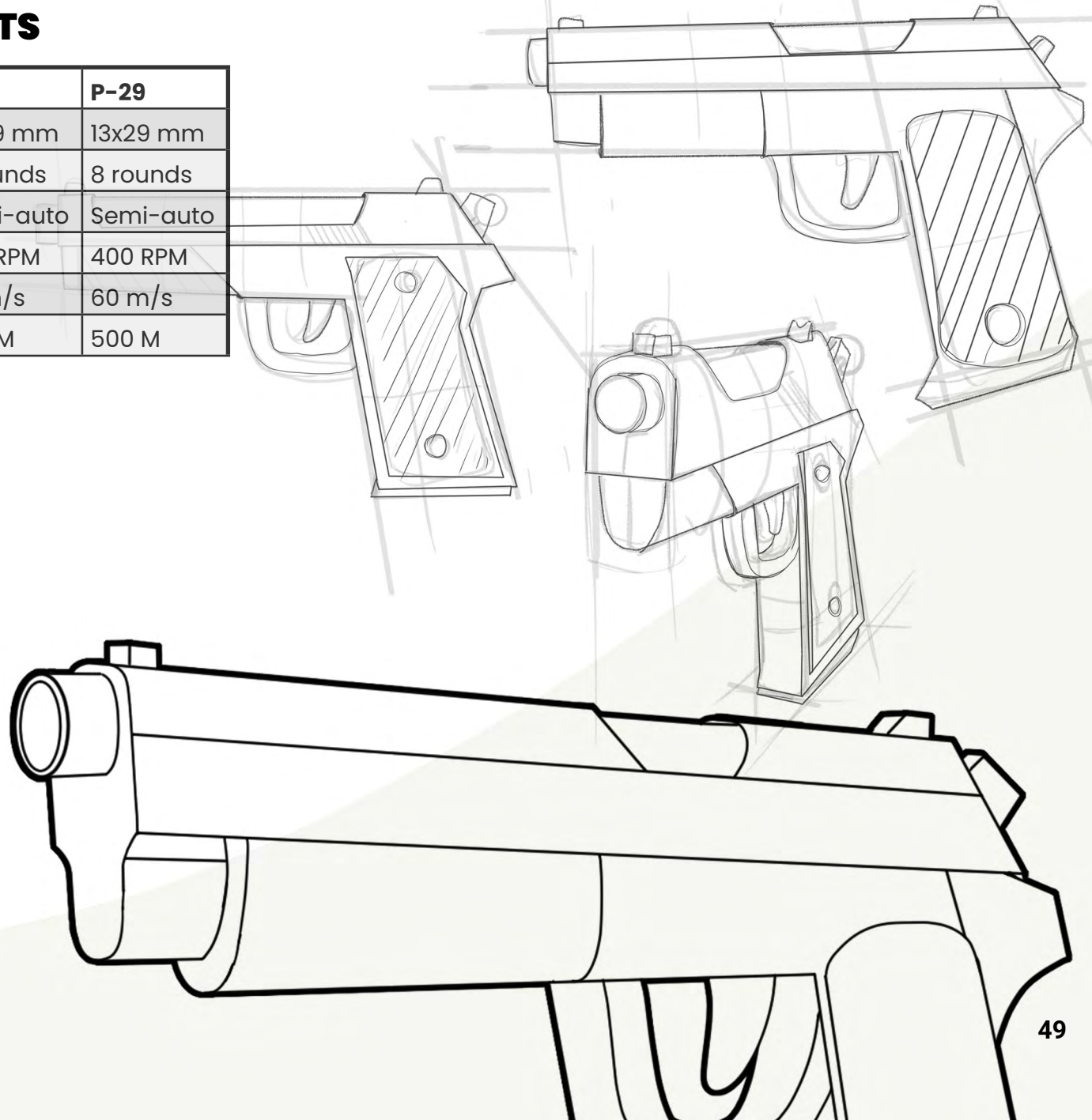

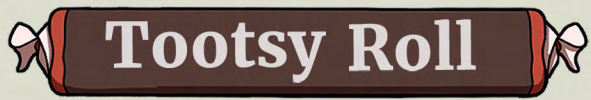

Tootsy Roll

13x71 mm



R-13



R-71

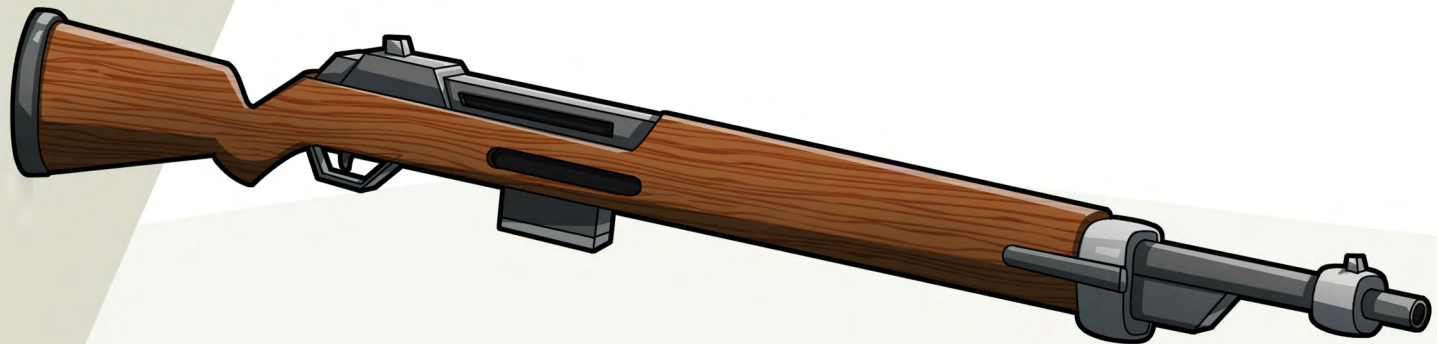

(SEMI-AUTO) RIFLES

WEAPON CONCEPTS

SPECIFICATIONS	R-13	R-71
CALIBER	13x71 mm	13x71 mm
MAG CAPACITY	6 rounds	6 rounds
FIRE MODE	Semi-auto	Semi-auto
RATE OF FIRE	286 RPM	316 RPM
MUZZLE VELOCITY	160 m/s	150 m/s
MAX RANGE	1000 M	1000 M

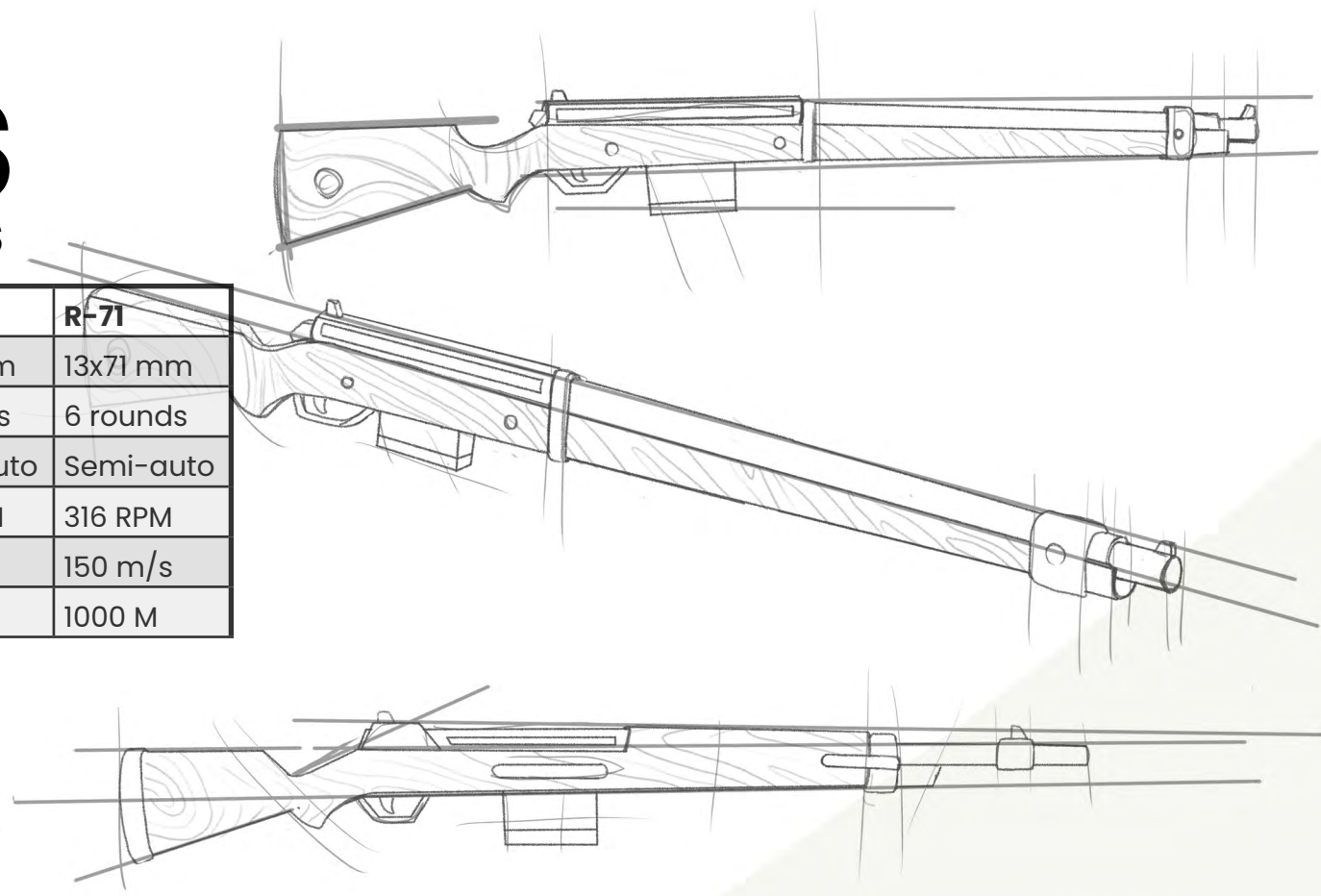

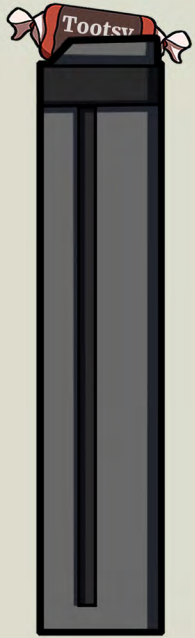

9x23 mm

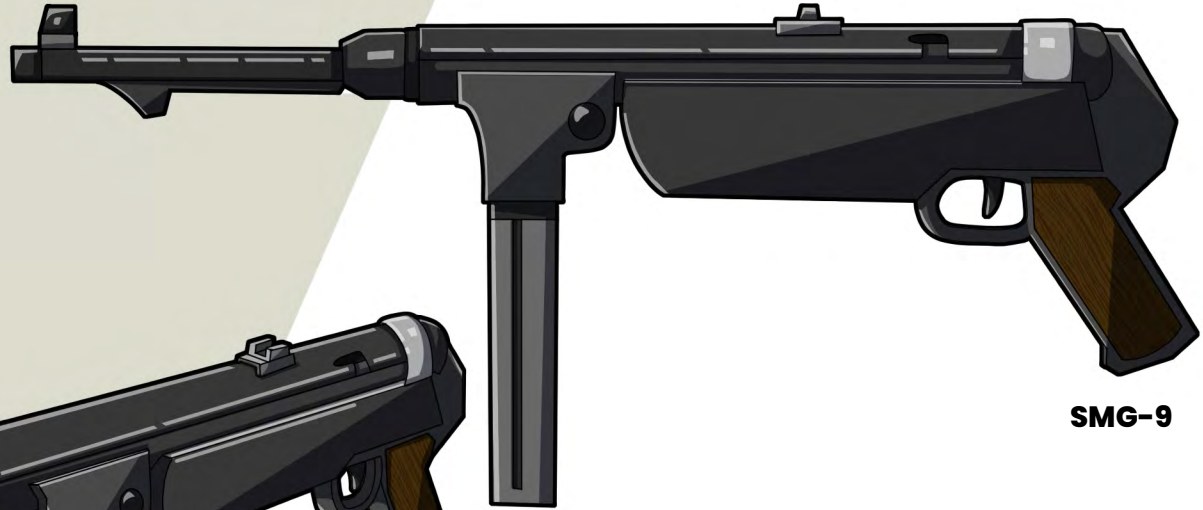

SMG-9

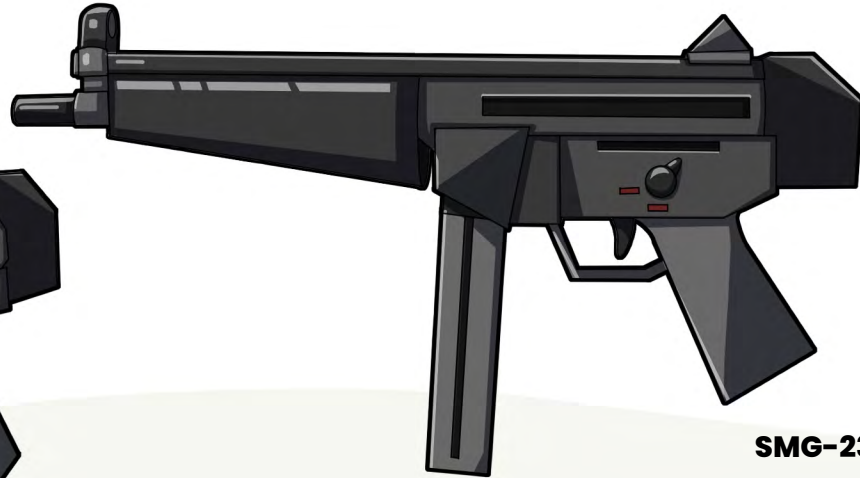
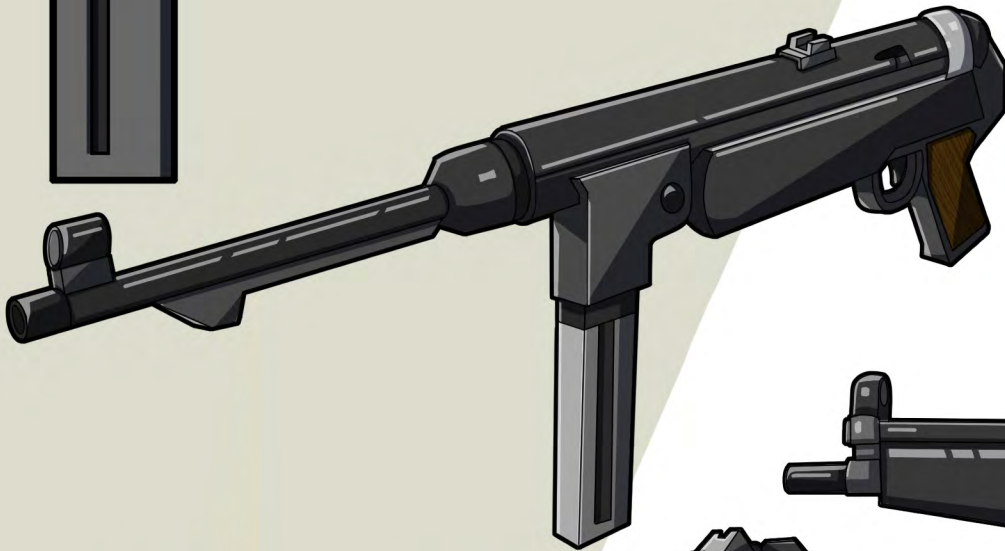

SMG-23

SMG

WEAPON CONCEPTS

SPECIFICATIONS	SMG-9	SMG-23
CALIBER	9x23 mm	9x23 mm
MAG CAPACITY	42 rounds	42 rounds
FIRE MODE	Full-auto	Full-auto
RATE OF FIRE	667 RPM	857 RPM
MUZZLE VELOCITY	70 m/s	60 m/s
MAX RANGE	500 M	500 M

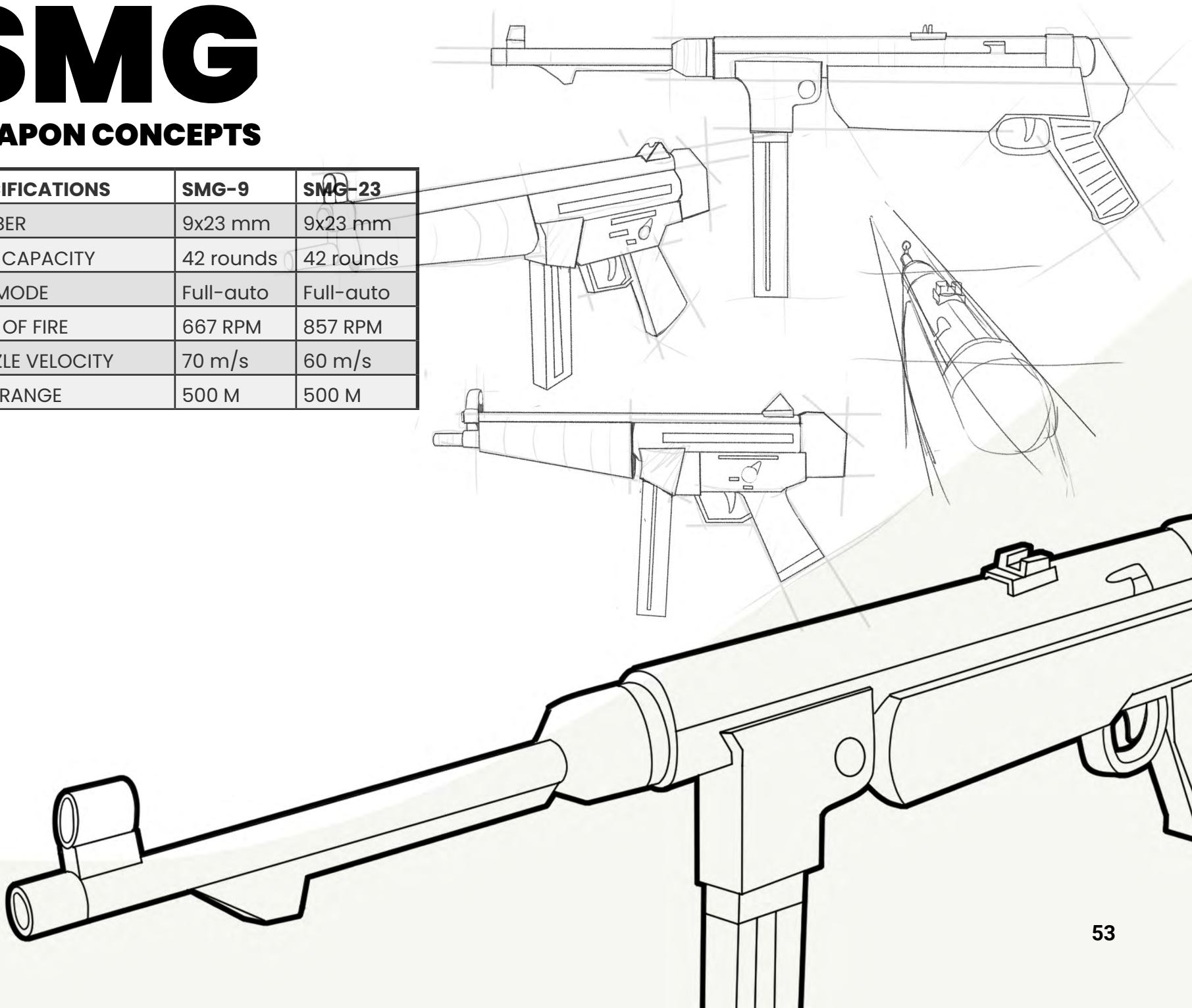

Tootsy Roll

Tootsy Roll

9x56 mm

Tootsy Roll

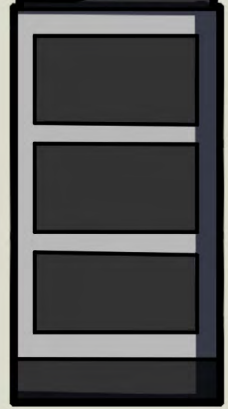

AR-56



AR-9

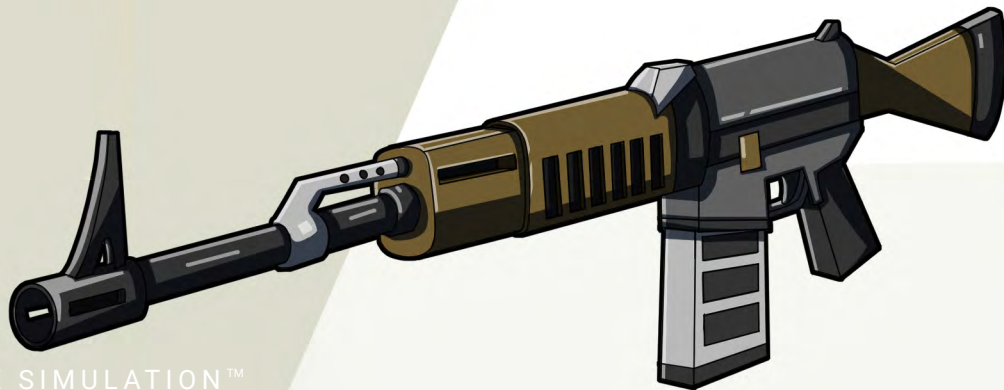

ASSAULT RIFLES

WEAPON CONCEPTS

SPECIFICATIONS	AR-9	AR-56
CALIBER	9x56 mm	9x56 mm
MAG CAPACITY	30 rounds	30 rounds
FIRE MODE	Full-auto	Full-auto
RATE OF FIRE	400 RPM	462 RPM
MUZZLE VELOCITY	110 m/s	100 m/s
MAX RANGE	800 M	800 M

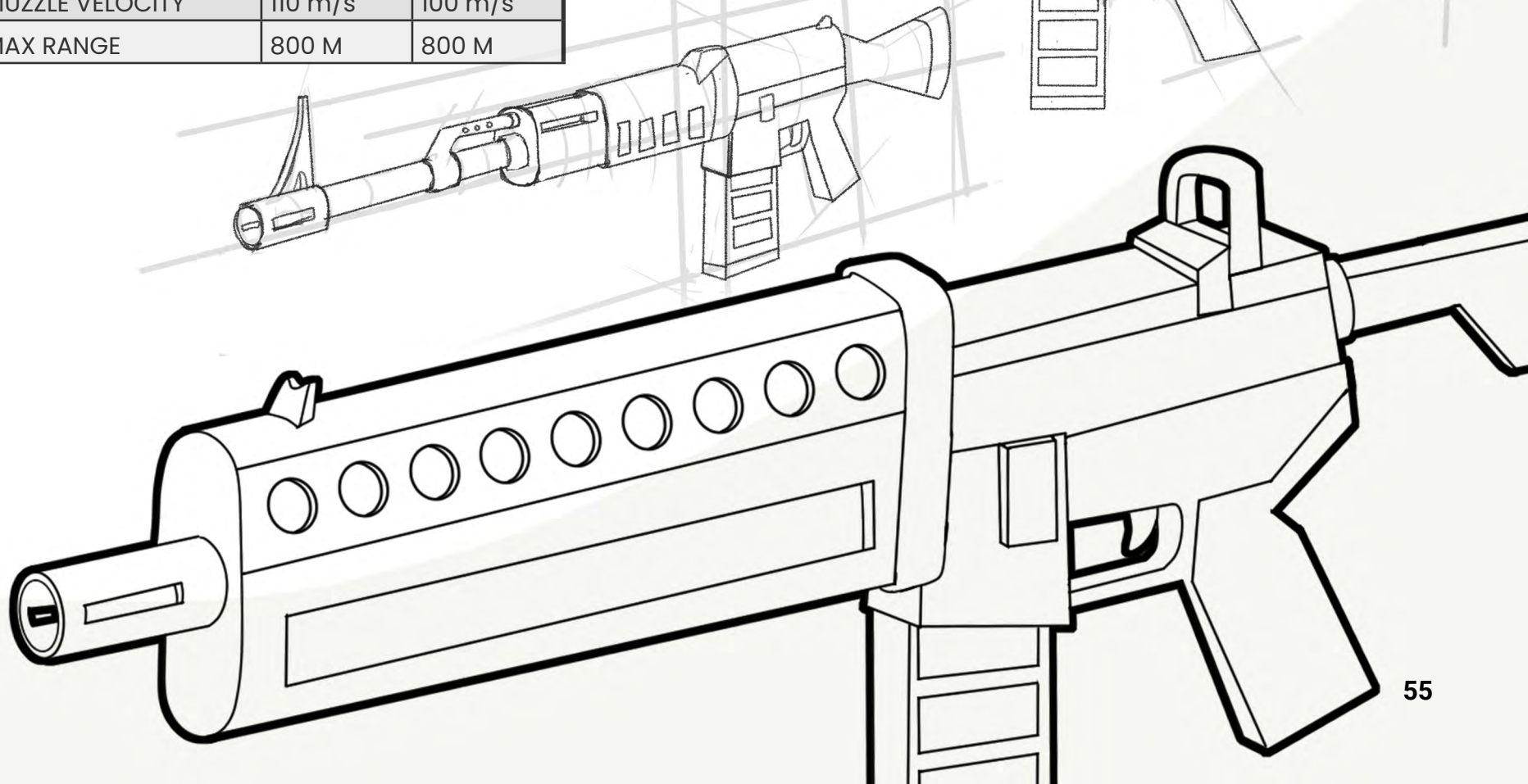



"Peace cannot be kept by force; it can only be achieved by understanding."

- Albert Einstein

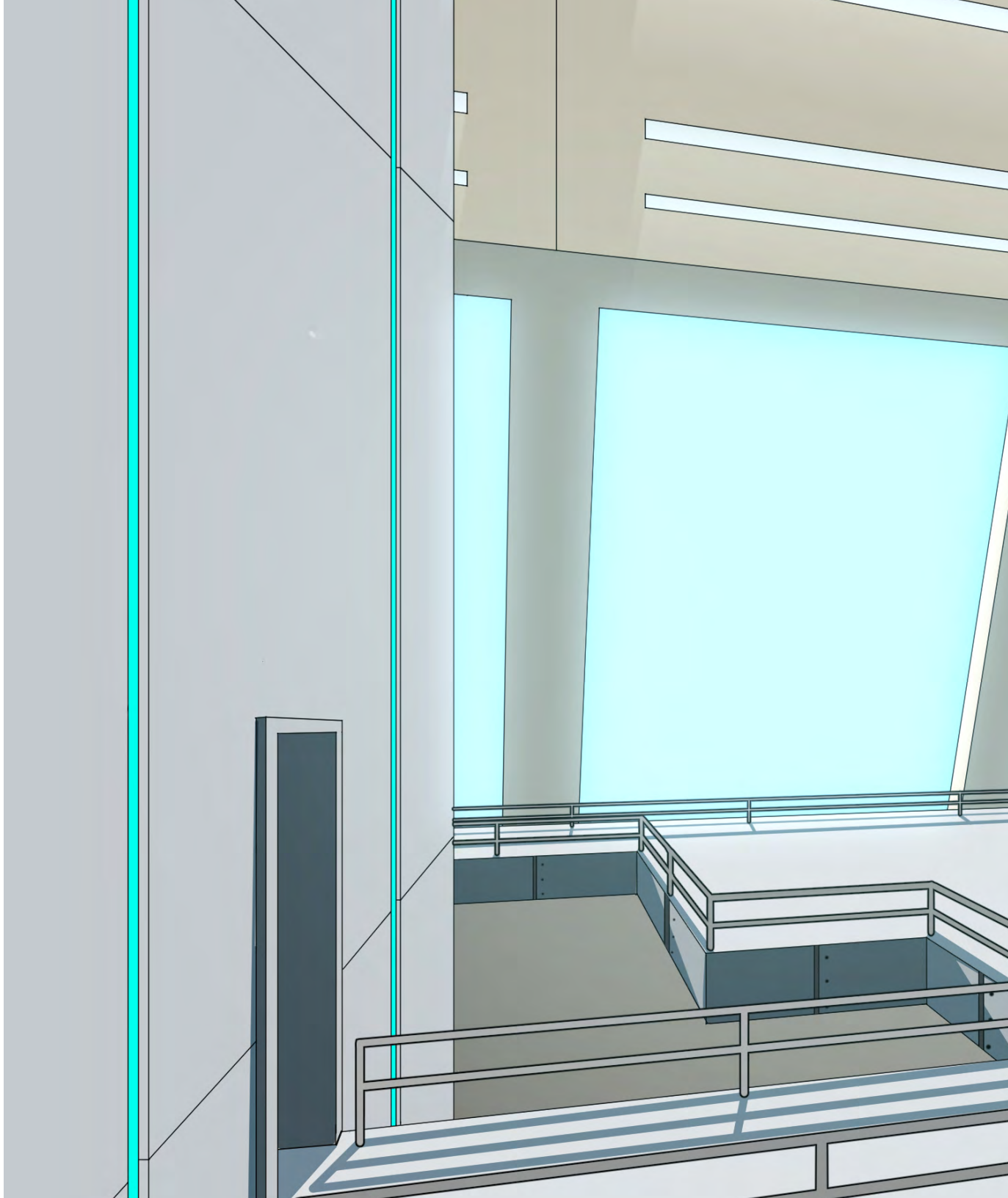

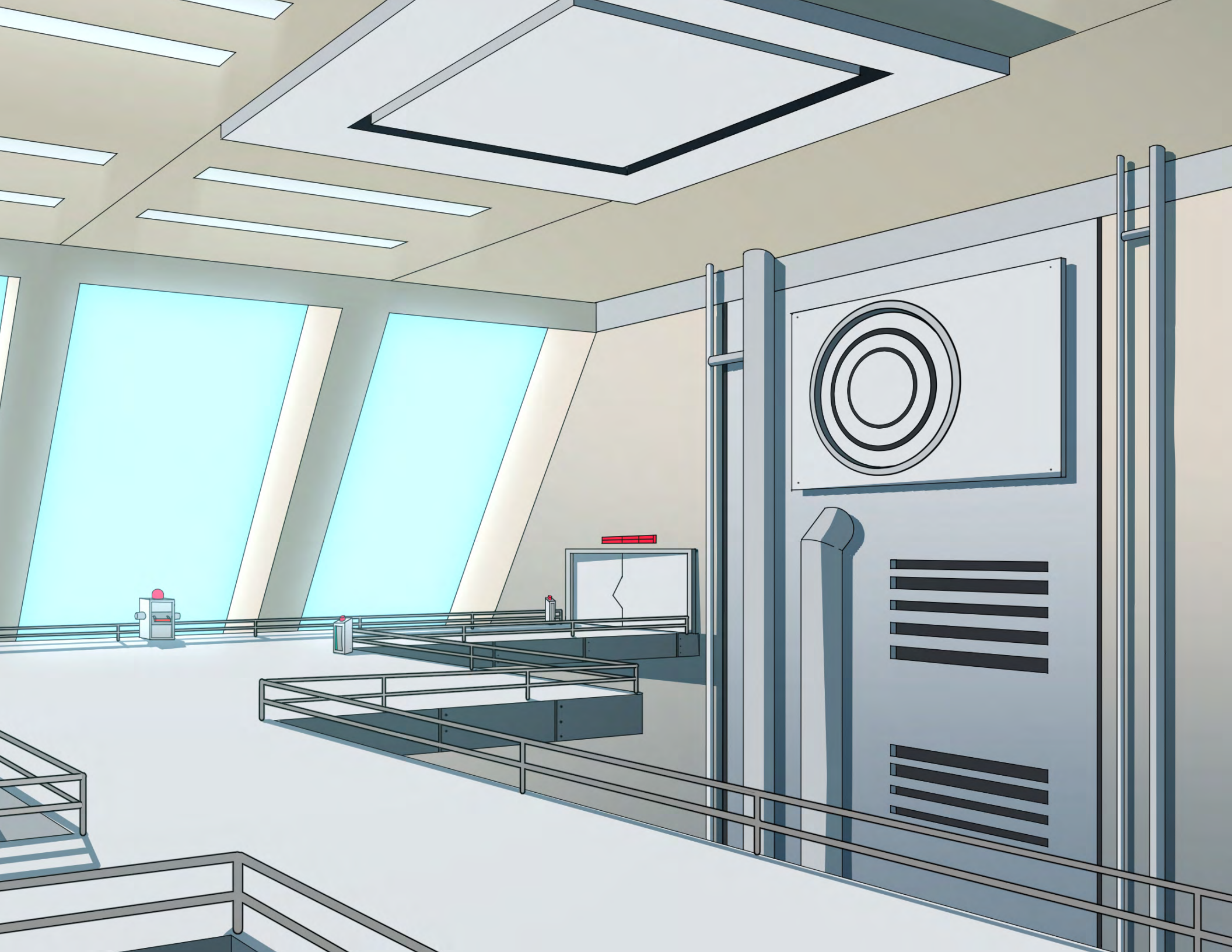

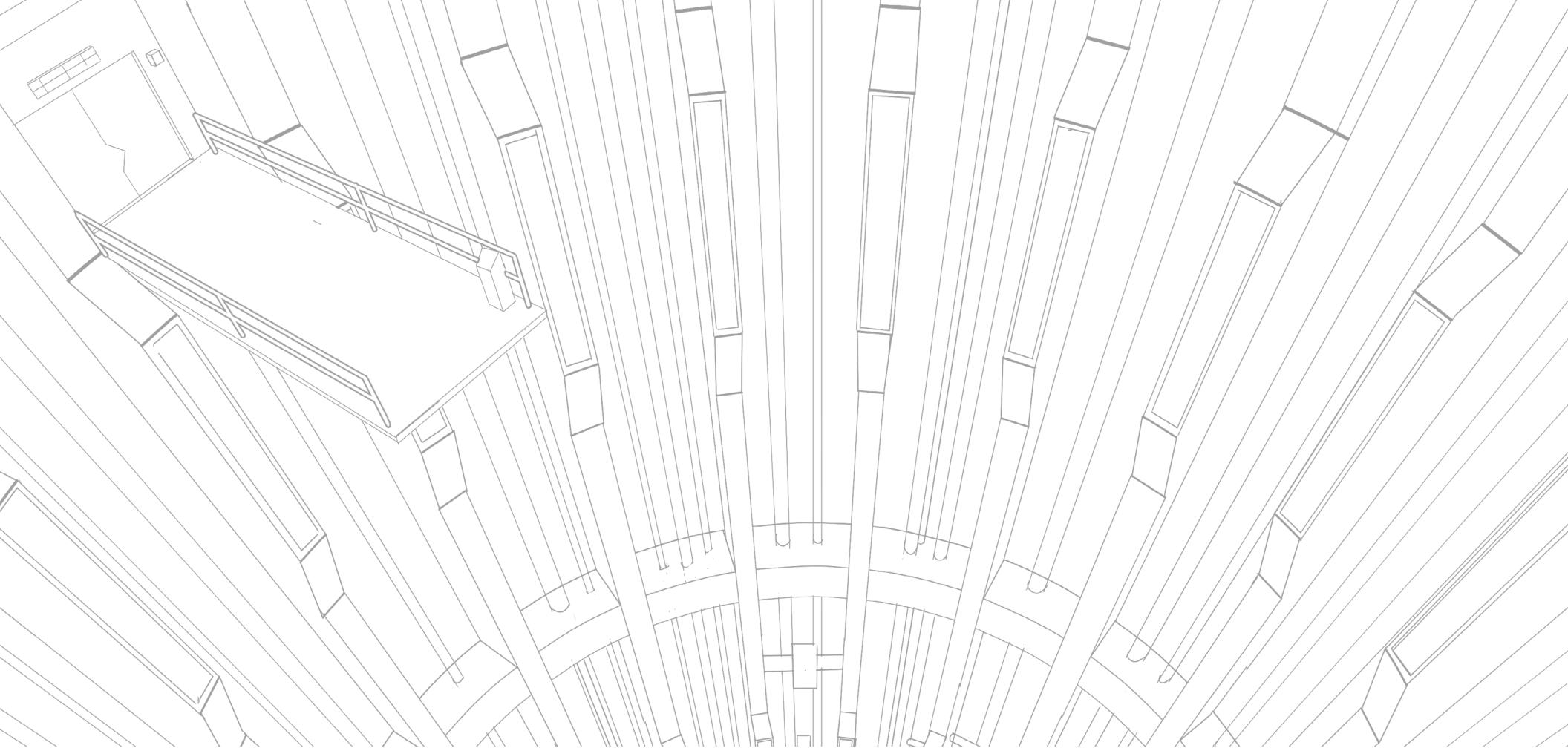

The visual style of The Simulation™ combines the intensity of war with the absurdity of a world inhabited by sentient Muffins and Donuts. The result is grounded conflict presented through a stylized, semi-cartoony aesthetic.

VISUALS



Character Design

Donuts and Muffins are anthropomorphized with candy corn arms and gumdrop legs. Characters use simplified, stylized clothing and accessories, such as small hats and floating glasses, to communicate personality and role without leaning into realism.

Environment

Environments reflect the progression of the war over time. Early stages are more rustic, while later periods show increasing technological advancement and the effects of prolonged conflict. These visual changes help orient the player within the timeline, providing context for where (and when) they are in the war as time shifts forward and backward.

Visual Effects

Visual FX support gameplay and storytelling. This includes explosions, tracer fire, and simulation distortions among others.

Inspiration

Combat visuals take inspiration from the film *Fury*, particularly in their use of tracer fire, impact, and battlefield chaos. Environmental design draws from *Walkabout Mini Golf*, which demonstrates how stylized VR spaces can remain expressive and performant.



“War is delightful to those who have not yet experienced it.”

- Erasmus

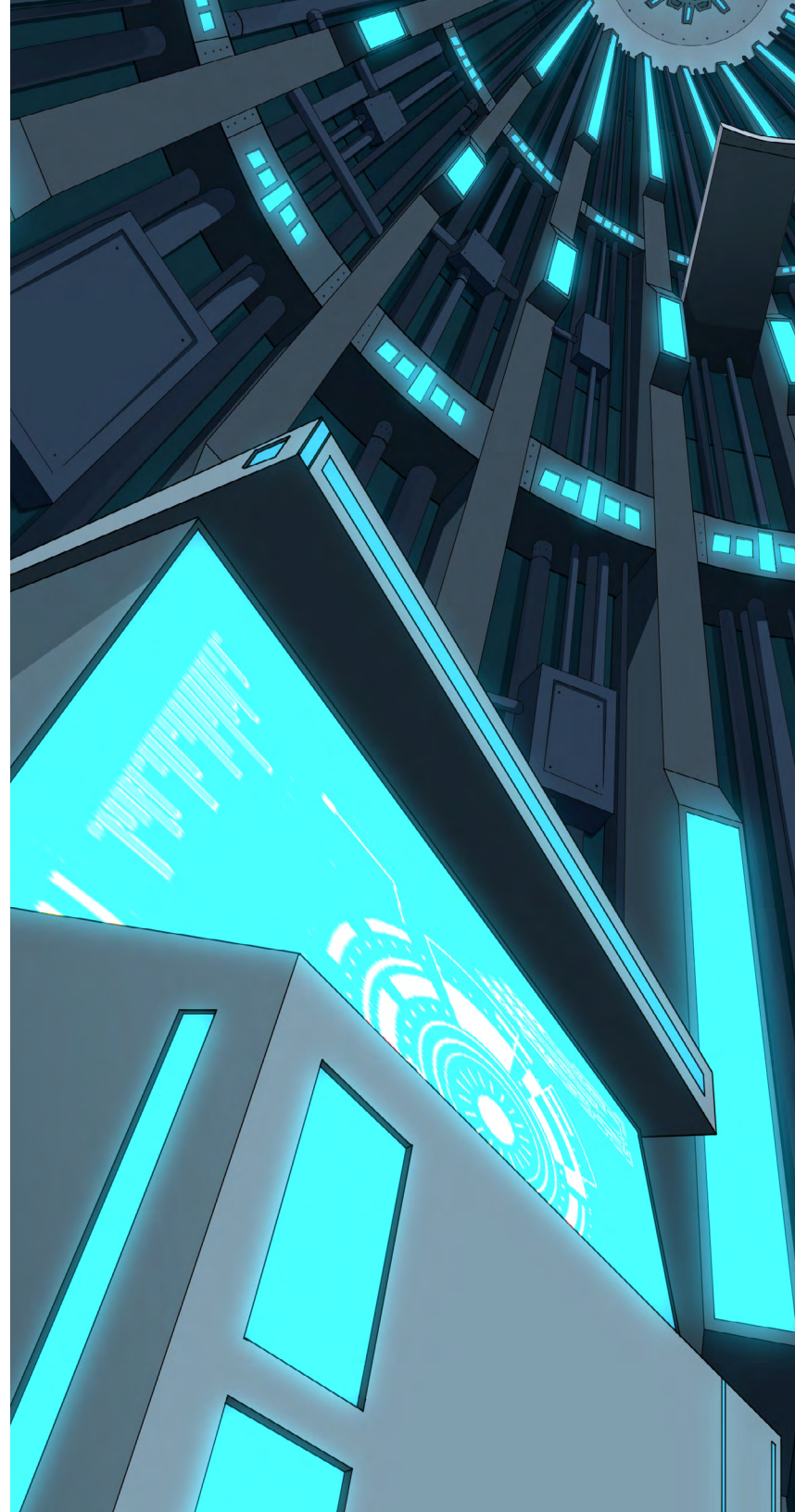

Sound in The Simulation™ is intended to support clarity, tone, and immersion. Audio is treated as a core part of the experience, grounding the player in the world and reinforcing the weight of events as they unfold.

SC

Ambient Sounds

Environmental audio establishes atmosphere and tension. Wind, distant movement, machinery, and battlefield noise help situate each scene within its setting. Silence is used deliberately, allowing moments to breathe and directing focus during critical situations.

Character Voices

Character voices convey personality, authority, and cultural distinction. Muffins speak with British-style accents, while Donuts speak with American-style accents. Dialogue is delivered entirely in-world, unfolding naturally through interaction rather than narration or cutscenes.

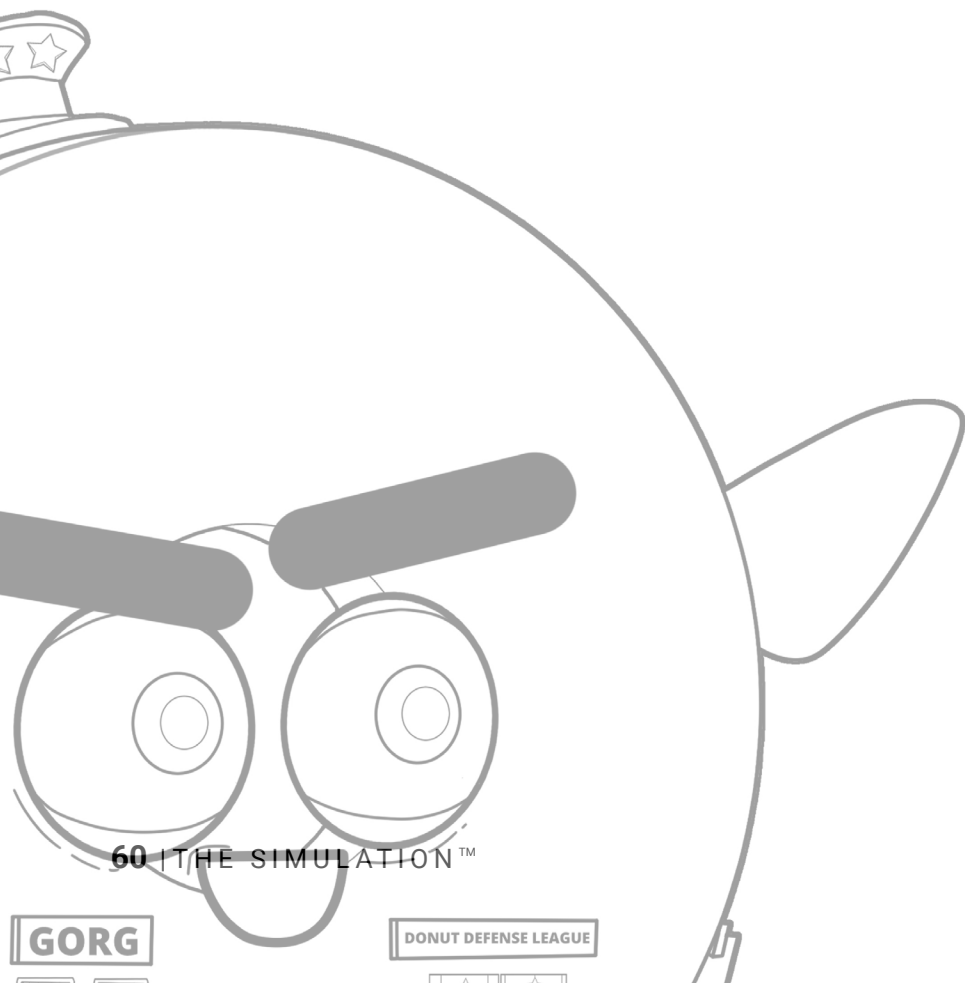

DUNND

Sound Effects

Sound effects emphasize the physicality and danger of combat. Weapons, explosions, and environmental interactions are intended to feel impactful and threatening while remaining clear and readable during gameplay.

Audio Feedback & Perception

Audio may be altered during intense moments to convey impact, using effects such as muffling or ringing. Subtle, non-diegetic cues, such as hit markers, are used sparingly for player feedback and are designed to blend seamlessly with in-world sound, enhancing impact without breaking immersion.

Music

The Simulation™ does not use traditional background music. There is no continuous score guiding emotion or pacing. All music is diegetic and exists within the world itself, such as radios, public broadcasts, anthems, or other in-world audio sources. In certain sequences, sound design may take on rhythmic or tonal qualities that function like music to achieve specific emotional effects, while remaining entirely diegetic.



“The truth, it is felt, becomes untruth when your enemy utters it.”

- George Orwell

The Simulation™ is an immersive gaming experience designed to captivate a diverse audience.

AUDI



*“Waste no more time arguing about what a good man should be. Be one.”
– Marcus Aurelius*

Casual Gamers

For players who want to jump in and play, The Simulation™ offers straightforward controls and clear objectives. The experience remains engaging without requiring extensive game knowledge or mechanical mastery.

Experienced Gamers

Experienced gamers know the disappointing feeling of playing a new game only to feel like they’ve already played it many times before. They do not need to worry about that happening with The Simulation™. This game is guaranteed to be a unique game unlike any other they’ve played before.

Hardcore Gamers

For players who consistently succeed, the game naturally remains more demanding. The Simulation™ features a dynamic difficulty system that adapts over time, becoming more forgiving when players struggle and remaining more challenging when they do not. As a result, players who rarely die will experience a tougher version of the game without needing to select explicit difficulty settings.

ENCE

Story Lovers

For those who value story above all else in their games, The Simulation™ provides a narrative rich in conflict, character development, and intrigue. The storyline allows for players to meaningfully affect the game's outcome, providing two distinct storytelling experiences.

Scholars of History

Even though The Simulation™ takes place in a fantasy world, the progression of its societies and the evolution of its conflict echo aspects of our real-world history. This lends a sense of realism and depth to the narrative, making it appealing to those who study history.

RATING

Despite having a cartoony and delicious aesthetic, The Simulation™ is not intended for children. The violence in this game is quite visceral, featuring destructible characters. Having said that, characters are desserts, making the violence no more graphic than putting googly eyes on a Donut and taking a bite.

Predicted rating is **T for Graphic Dessert Violence**. Notably, there is no strong language, as real expletives are substituted with thematically appropriate counterparts like "cranberry sauce," "holy sprinkles," and "fudge!"

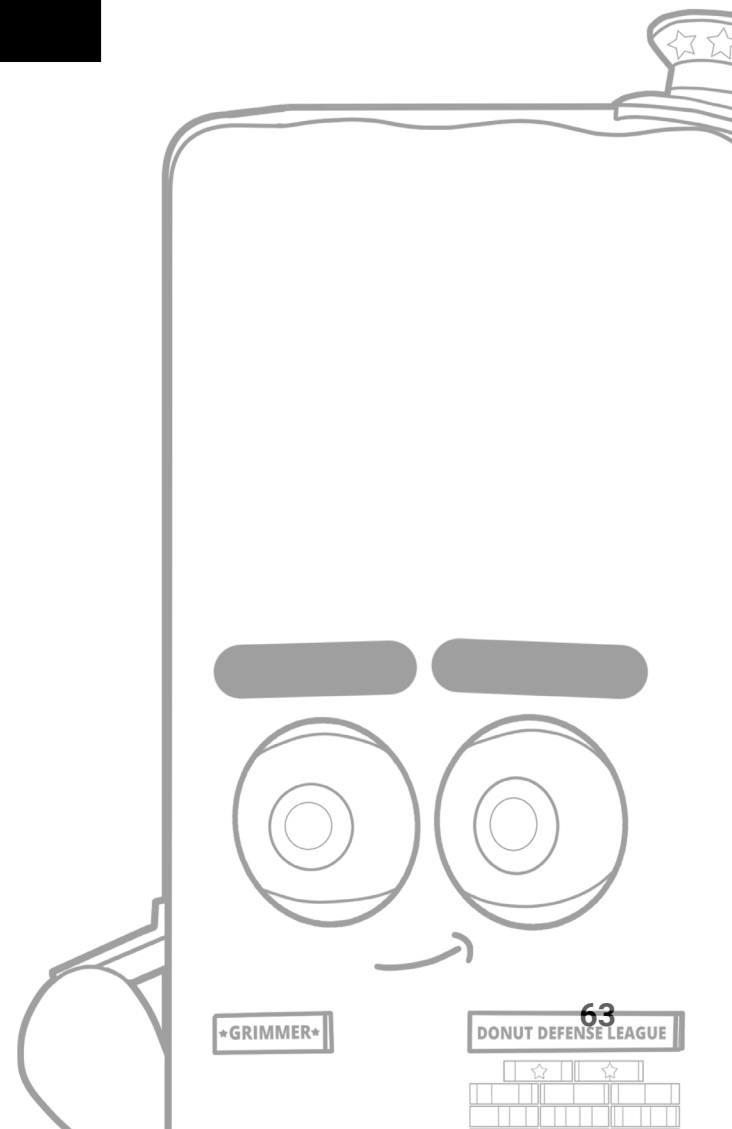

DEVELO

The Simulation™ is a large, story-driven project, and its development is structured deliberately to reduce risk and validate core ideas before committing to full production. Progress is divided into distinct stages, each with a specific goal that must be met before moving forward.

Stage 1: Act 1 Vertical Slice (Current Focus)

The full story of The Simulation™ is structured into 5 acts, spanning approximately 99 scenes. The current focus is the complete development and polish of Act 1, which consists of nine scenes.

Act 1 is treated as a fully playable vertical slice rather than a demo. It is designed to represent the game as a whole, including narrative flow, combat, player choice, simulation mechanics,

and overall tone. Most of the core systems intended for the final game appear in some form during this act.

The goal of this stage is to ensure the game is genuinely fun, coherent, and mechanically sound before expanding its scope. Act 1 serves as a test of both the creative vision and the practical execution of the game.

Stage 2: Full Production Planning

Once Act 1 is complete and validated, the next stage is to plan the full game in detail. This includes locking scope, pacing, and structure across all five acts, as well as determining realistic timelines, resource requirements, and team needs.

Decisions around funding, hiring, and partnerships are made during this stage, informed by the lessons learned from Act 1. Full production does not begin until the foundation has proven itself.



P M M E N T

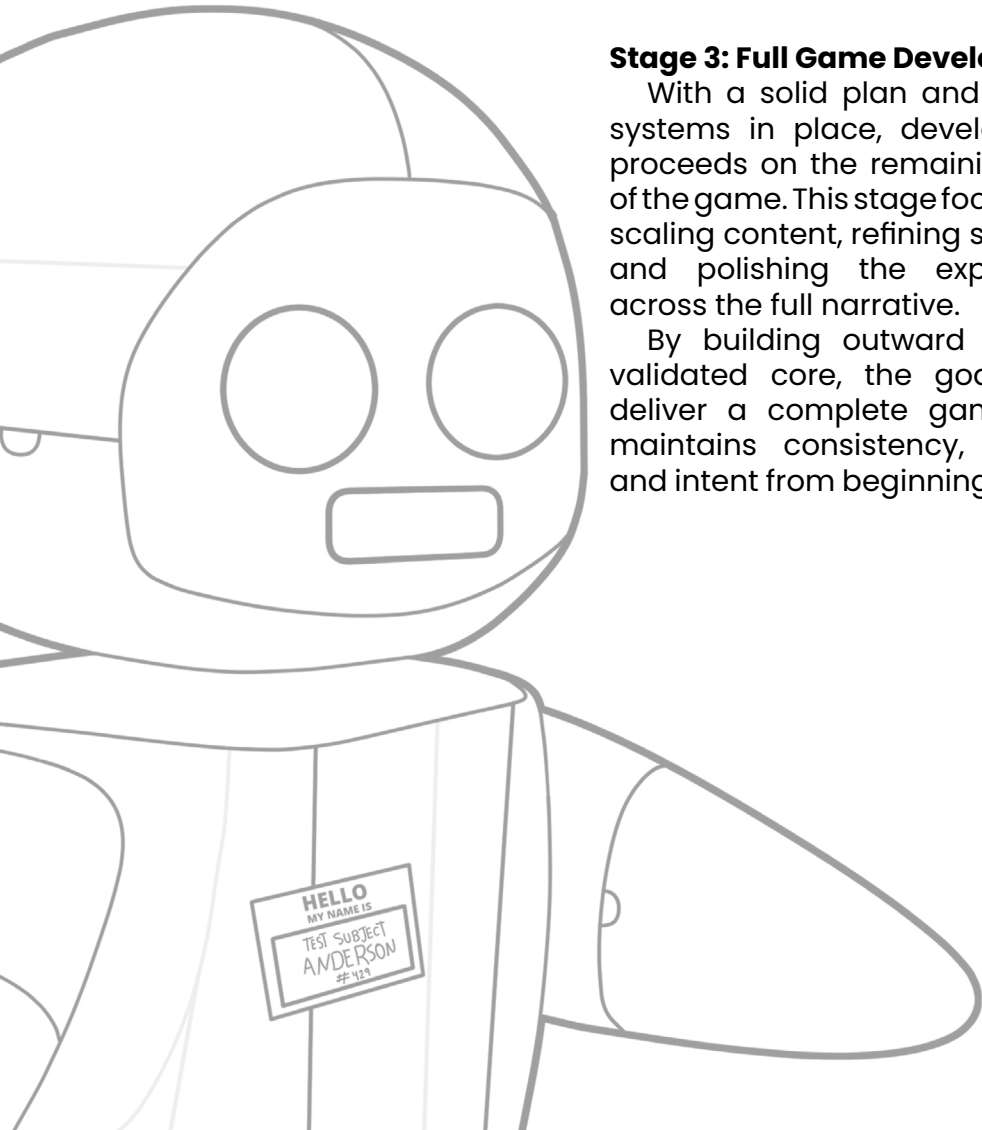

Stage 3: Full Game Development

With a solid plan and proven systems in place, development proceeds on the remaining acts of the game. This stage focuses on scaling content, refining systems, and polishing the experience across the full narrative.

By building outward from a validated core, the goal is to deliver a complete game that maintains consistency, quality, and intent from beginning to end.

// *"You may have to fight a battle more than once to win it."*
- Margaret Thatcher

PLATFORM

The Simulation™ is a VR game designed to run across a wide range of headsets. While optimization is a priority, development is not constrained by the limitations of today's hardware. By the time the game releases, current standalone devices may be phased out, with more powerful headsets becoming the norm.

The goal is to make the game **accessible on as many VR platforms as possible**. Temporary platform exclusivity is acceptable if it supports development, but long-term accessibility remains the priority. Support for alternative input methods, including hand tracking, is also considered where appropriate as VR hardware continues to evolve.

MARKE



"Everyone sees what you appear to be, few experience what you really are."

- Niccolo Machiavelli

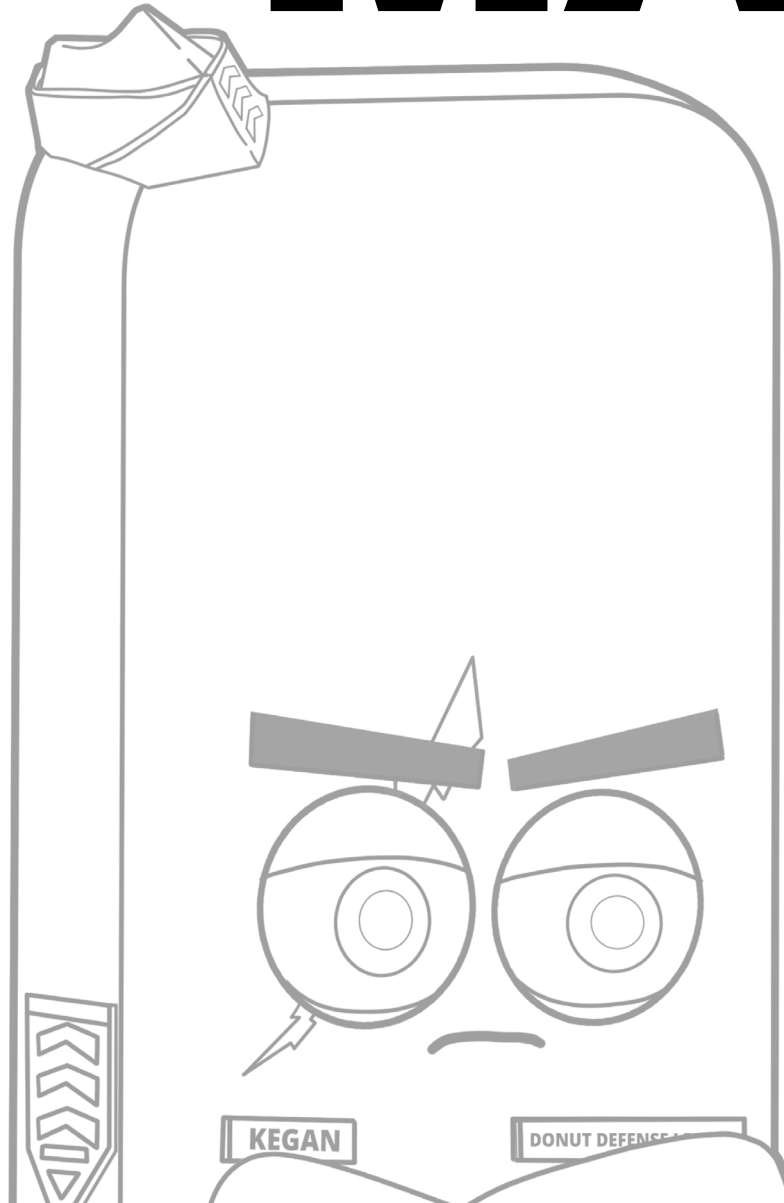

Marketing for The Simulation™ is approached as a structured, deliberate process rather than a broad promotional campaign. The focus is on clarity, positioning, and validation, ensuring that the project is introduced to the right audience at the right time, with the right expectations.

TING

Purpose of Act 1

Act 1 is used as a controlled release to test messaging, positioning, and player response before committing to larger-scale efforts. It functions as both a narrative experience and a proof of concept. It demonstrates tone, pacing, world-building, and the project's underlying design philosophy in a contained, standalone form.

Pre-Release Approach

Before release, marketing efforts remain intentionally limited. From a marketing perspective, Act 1 allows us to observe how players interpret the experience, what aspects resonate most strongly, and how the project is discussed organically, without relying on aggressive promotion. We will engage with people at conferences and meetups. The goal during this phase is alignment, not reach.

Beyond the Release of Act 1

The release of Act 1 will mark the start of a more active marketing phase. This will include the gradual establishment of a Discord community, ongoing developer logs, and structured opportunities for direct interaction with the team through AMAs and post-release discussions. These efforts are intended to support players who choose to engage early, create space for meaningful feedback, and allow the community to grow around the project in an intentional and sustainable way.

MONETIZATION STRATEGY

The Simulation™ is planned as a premium, upfront purchase with no microtransactions or in-game monetization mechanics.

The **full game** is intended to be priced in the **\$30-\$40** range, reflecting its scope as a complete, story-driven VR experience. **Act 1**, released as an early standalone entry, is planned to be priced at **\$10**. This higher relative price is intentional, positioning Act 1 as an early-access experience for more committed players rather than a mass-market release.

This approach allows the initial player base to remain smaller and more focused, with broader accessibility reserved for the full game's release.

// *“Wars are poor chisels
for carving out peaceful
tomorrows.”*
– Martin Luther King, Jr.



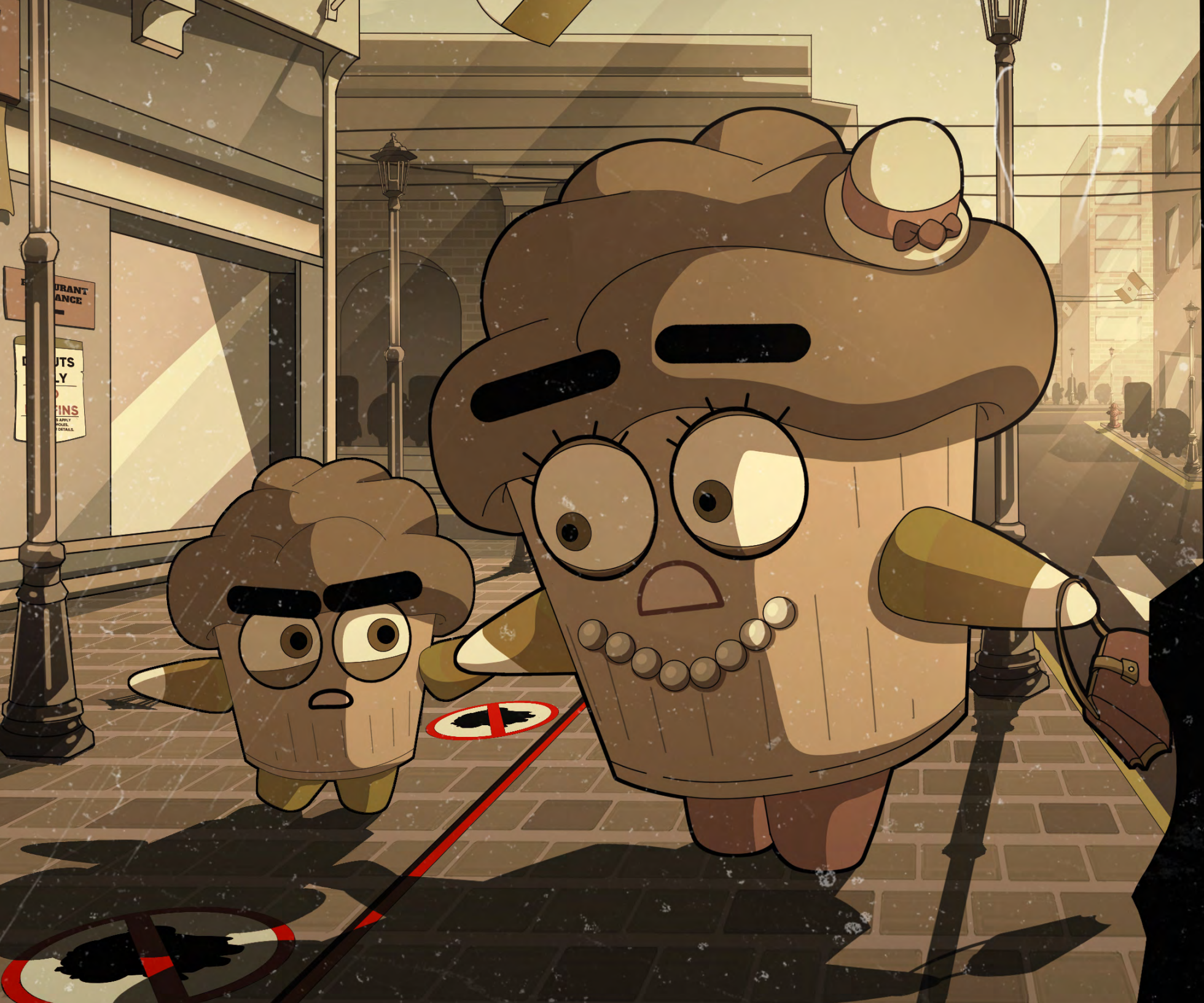

This section is a collection of visual material created throughout development. It includes a mix of concept art, sketches, environment art, standalone illustrations, and more.

The artwork shown here represents different stages and purposes, serving as visual exploration, reference, and documentation as the game continues to take shape.

ART

*“Peace is not the absence of conflict, it is the ability to handle conflict by peaceful means.”
– Ronald Reagan*











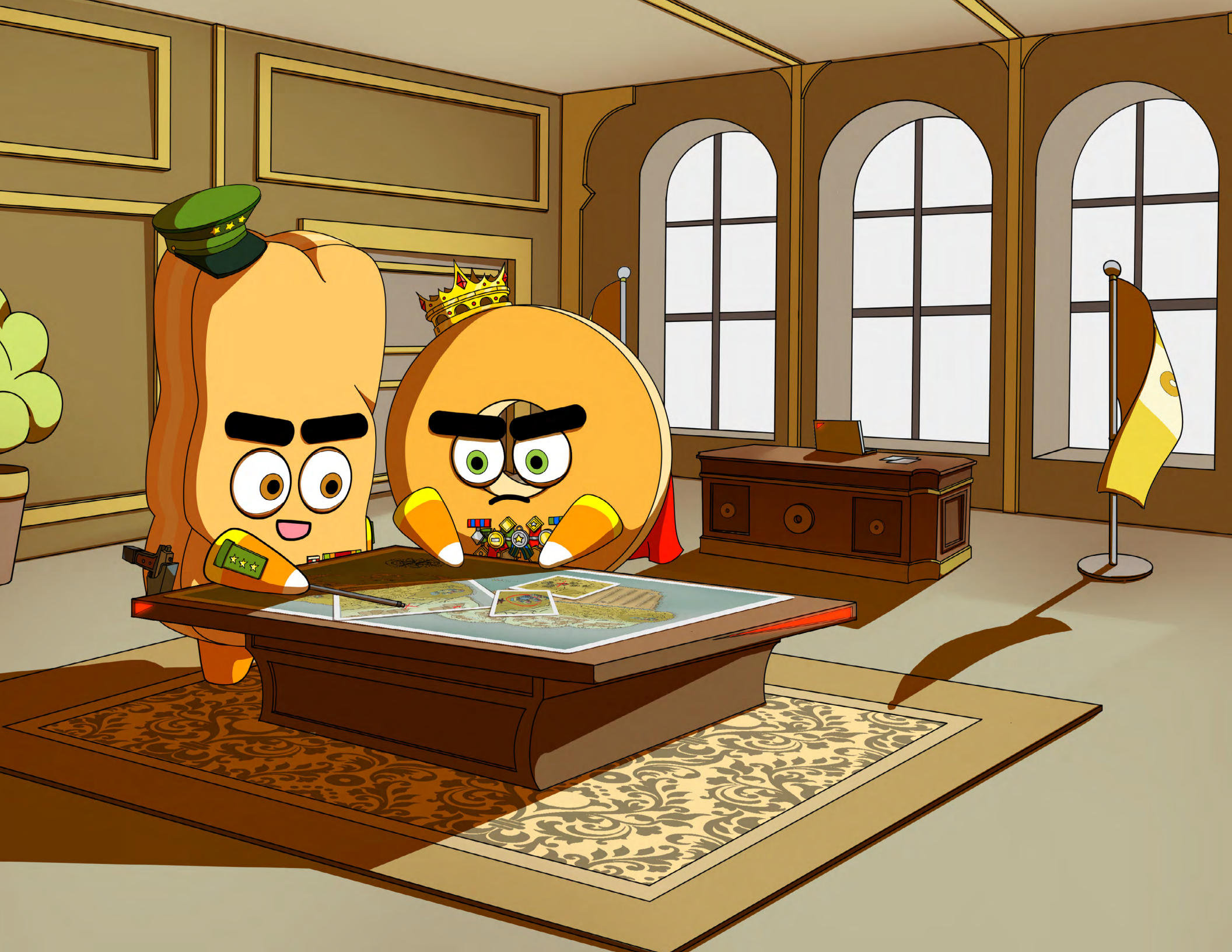





REGAL MEADOW
FINE DINING

NOW OPEN

RESTAURANT
ENTRANCE
←

DONUTS
ONLY
NO
MUFFINS
RESTRICTIONS APPLY
TO DONUT HOLES.
SEE STAFF FOR DETAILS.

RESTAURANT
ENTRANCE
←
DONUTS
ONLY
NO
MUFFINS
RESTRICTIONS APPLY
TO DONUT HOLES.
SEE STAFF FOR DETAILS.





GORG

DONUT DEFENSE LEAGUE

COMCAM





WE MUST PROTECT
THEIR FUTURE



**THE MUFFINS
NEED YOU**



**TOGETHER
WE WIN**



WE WILL



OVERCOME!



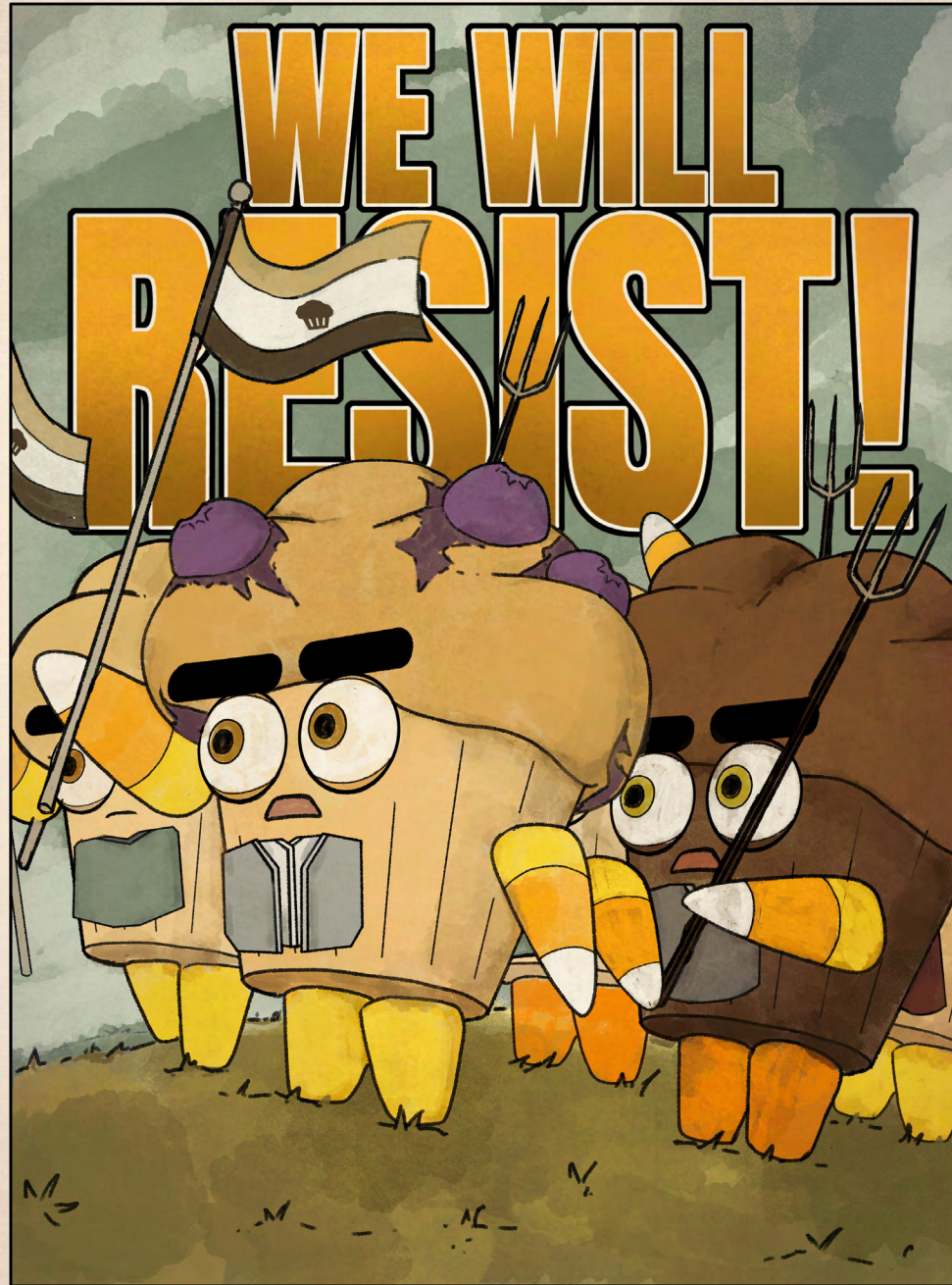



**BEWARE
THE MUFFIN
MENACE**



**DON'T BE FOOLED
MUFFIN SWEETNESS MASKS
THE SAVAGERY WITHIN**

**BE VIGILANT
MUFFIN SAVAGES
LURK AMONG US!**

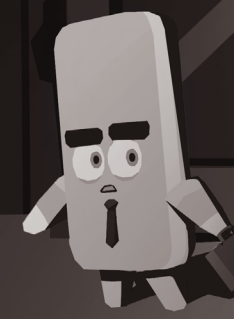

PRESERVE OUR PROUD DONUT HERITAGE



ARE YOU TOUGH
ENOUGH?

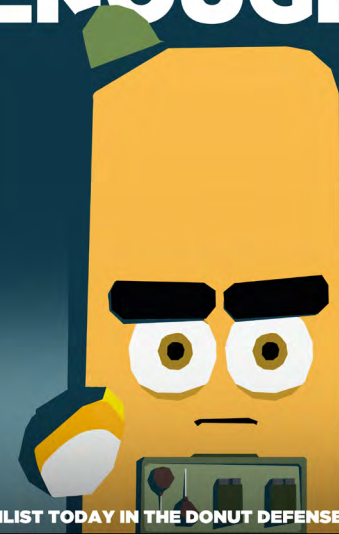

ENLIST TODAY IN THE DONUT DEFENSE LEGION!

FRESH RECRUITS
NEEDED!

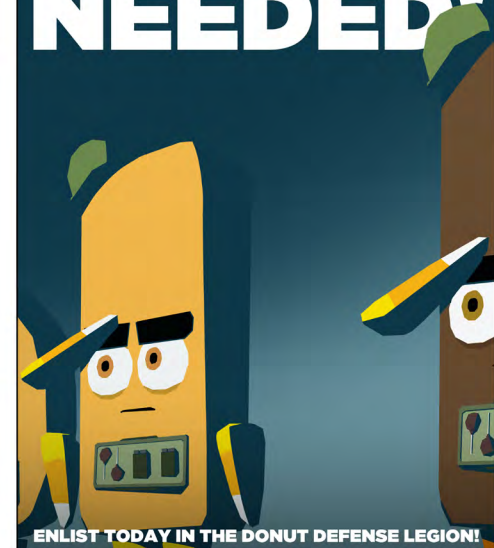

ENLIST TODAY IN THE DONUT DEFENSE LEGION!

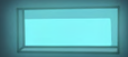
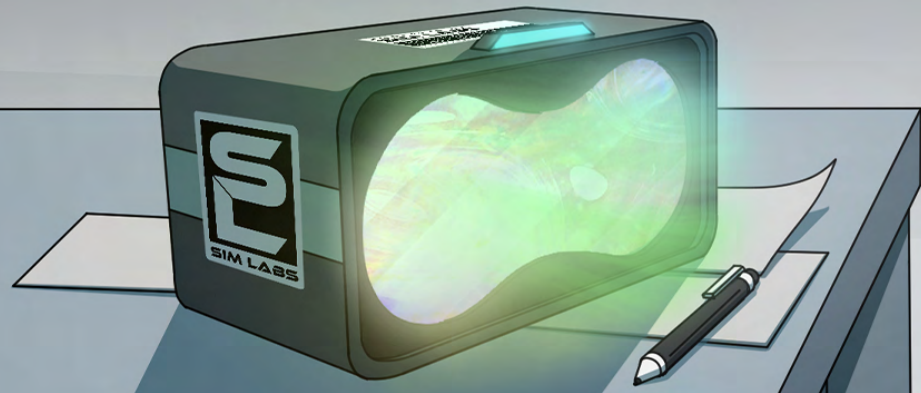
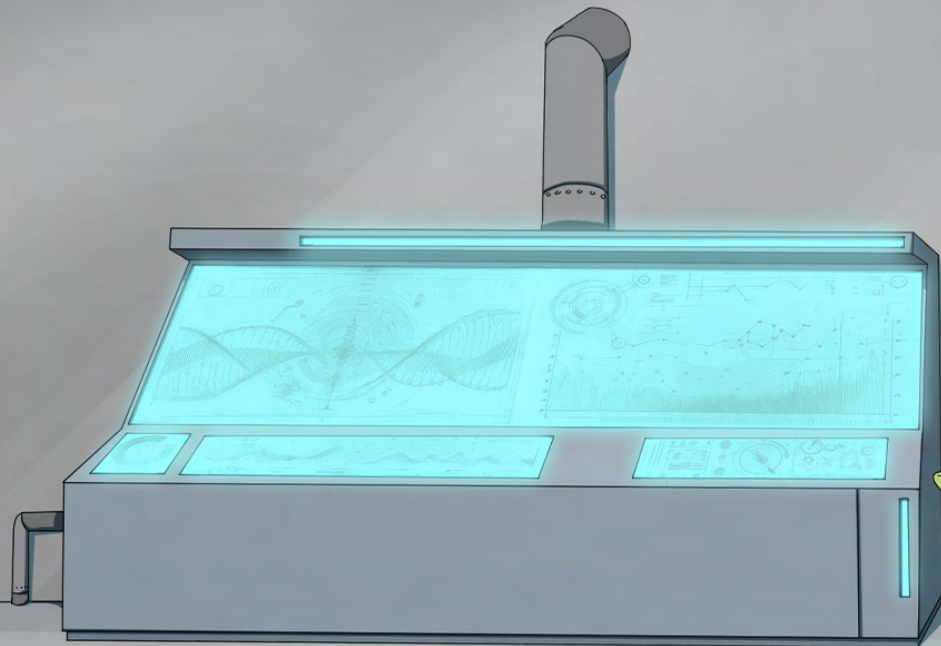



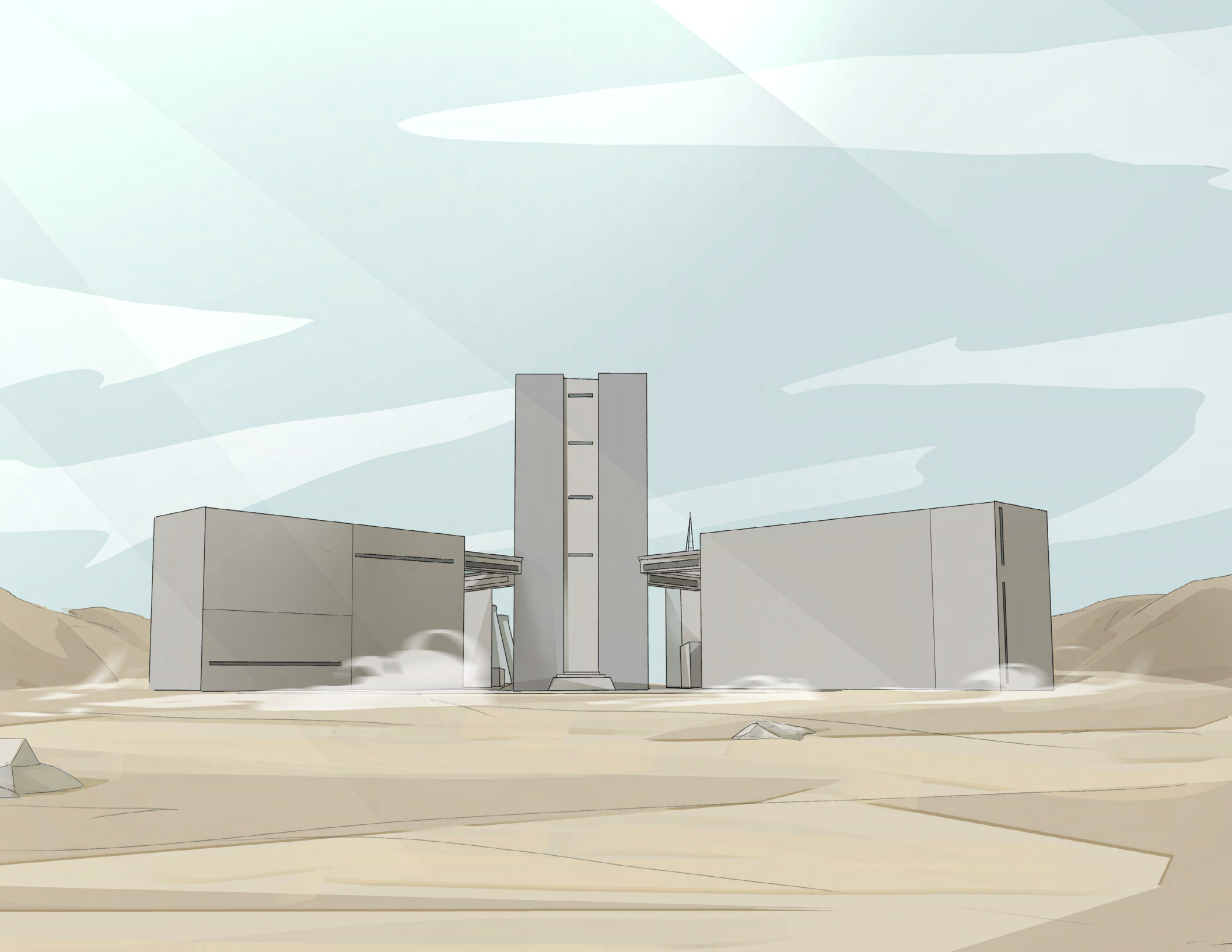

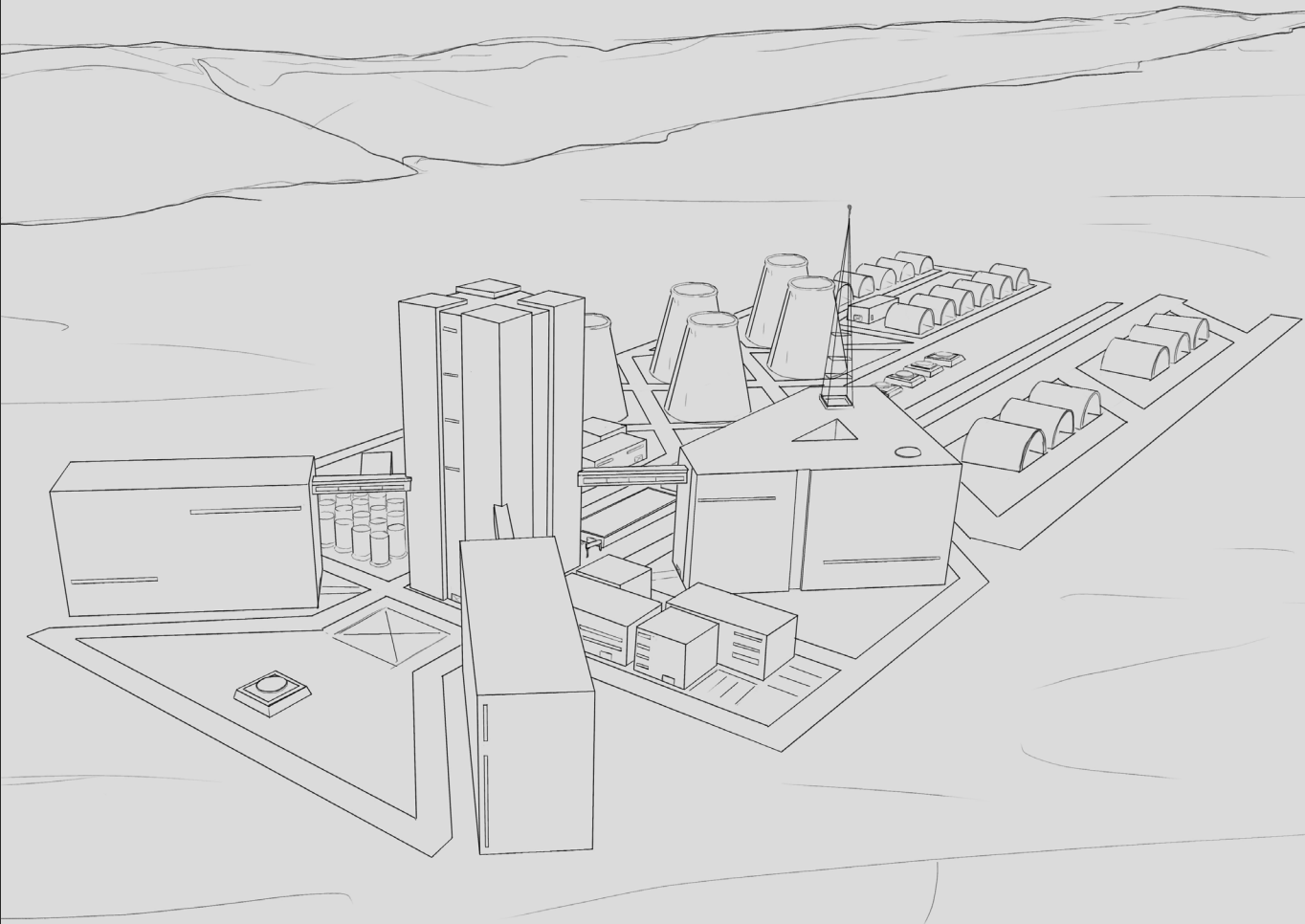
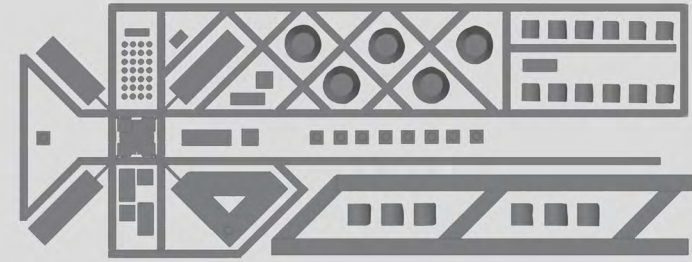
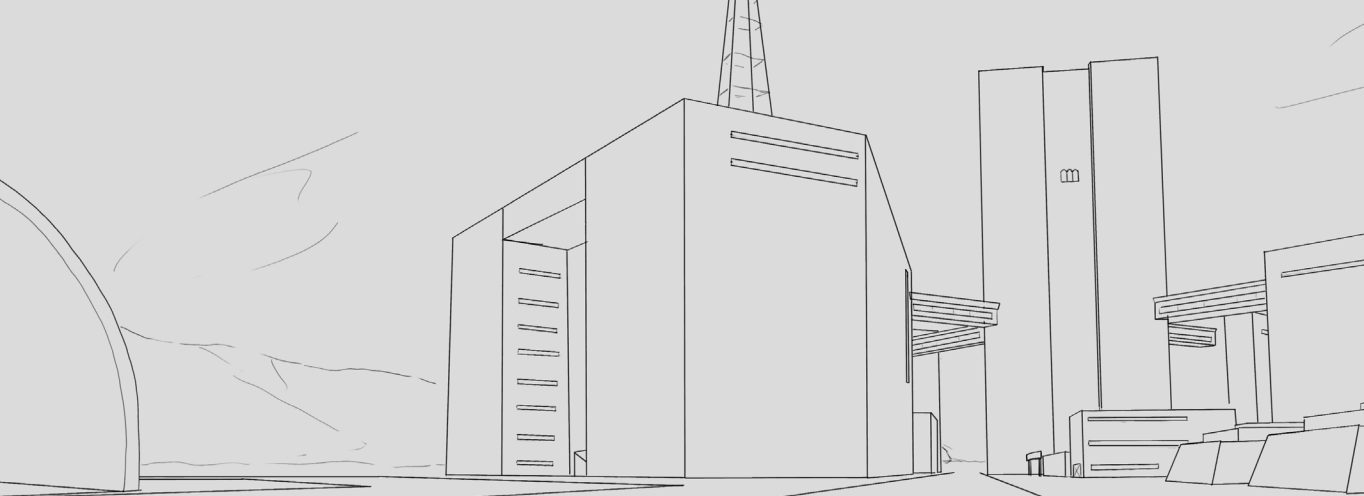

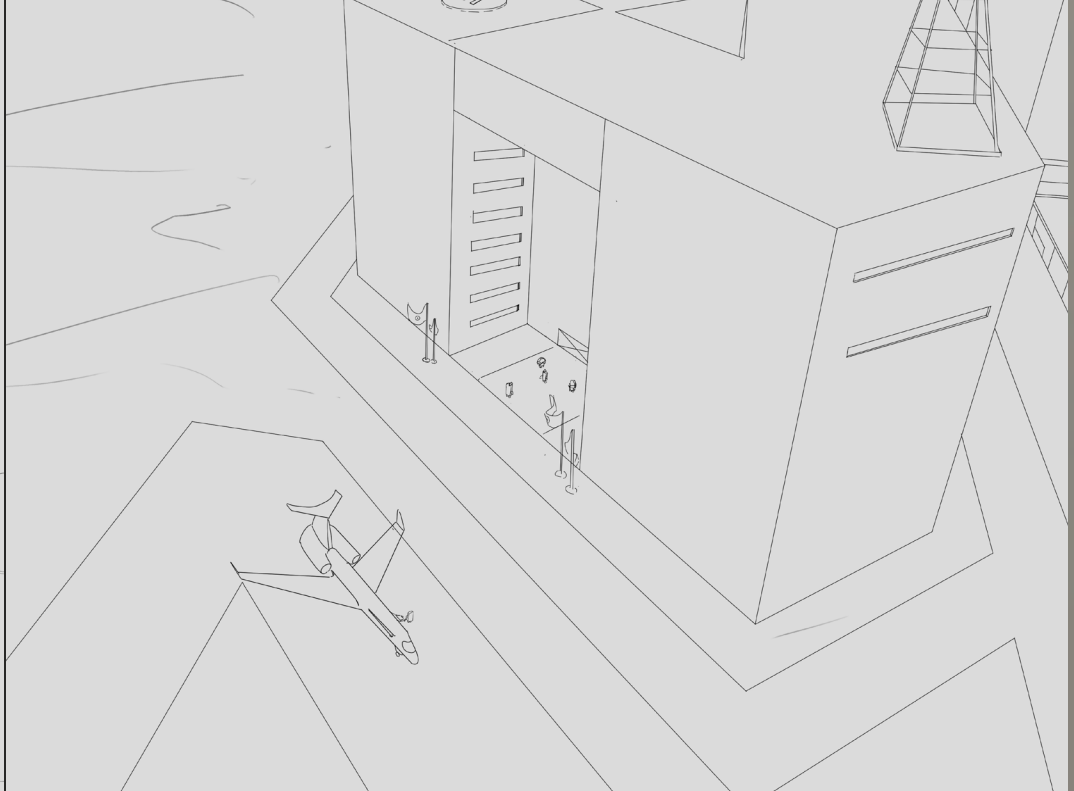
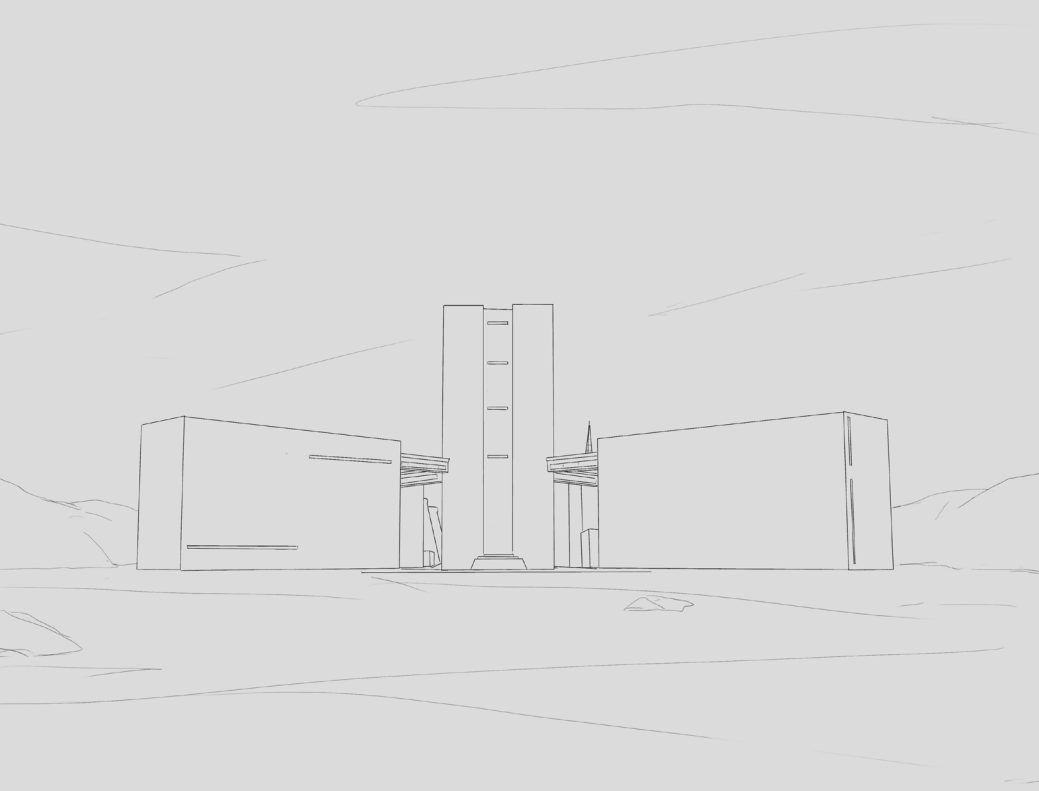

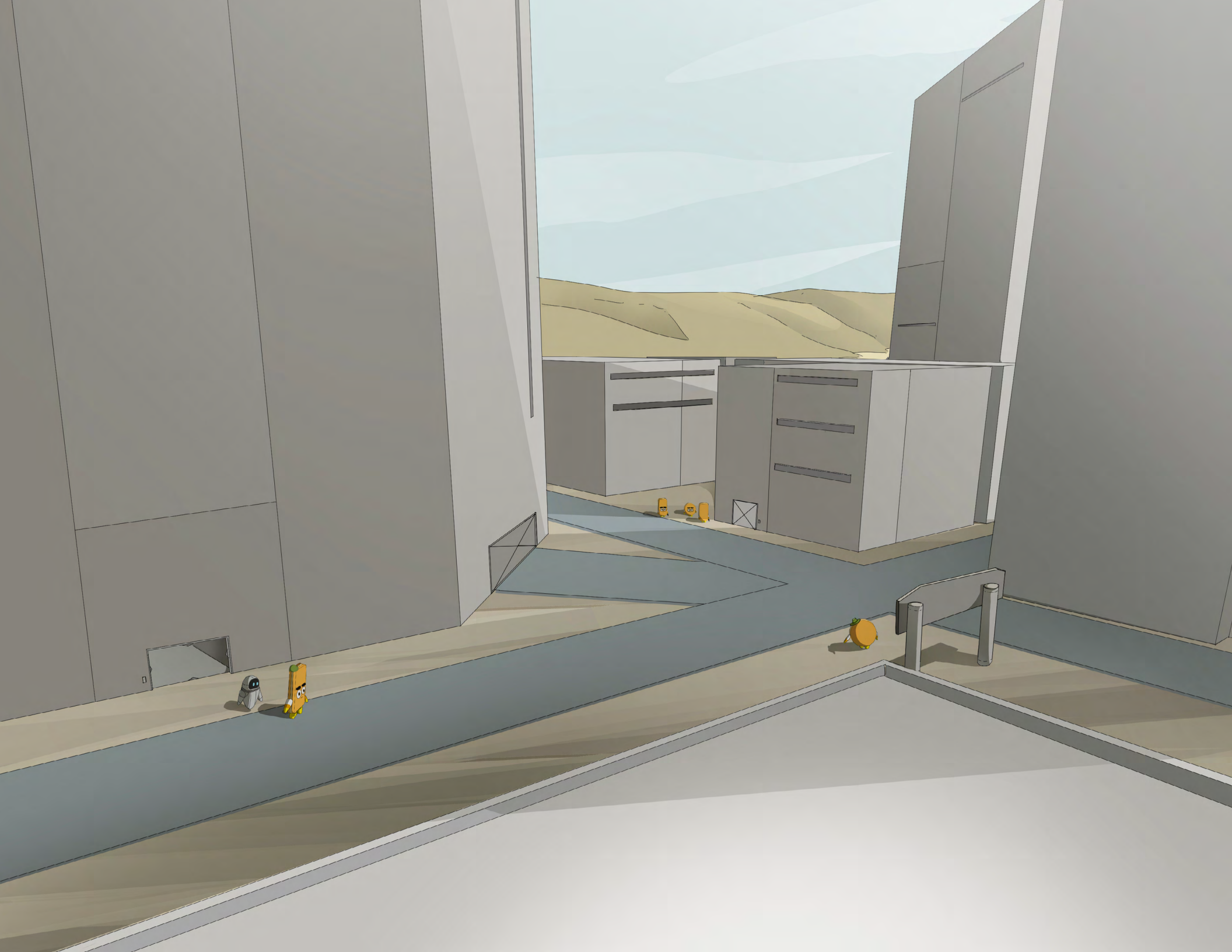

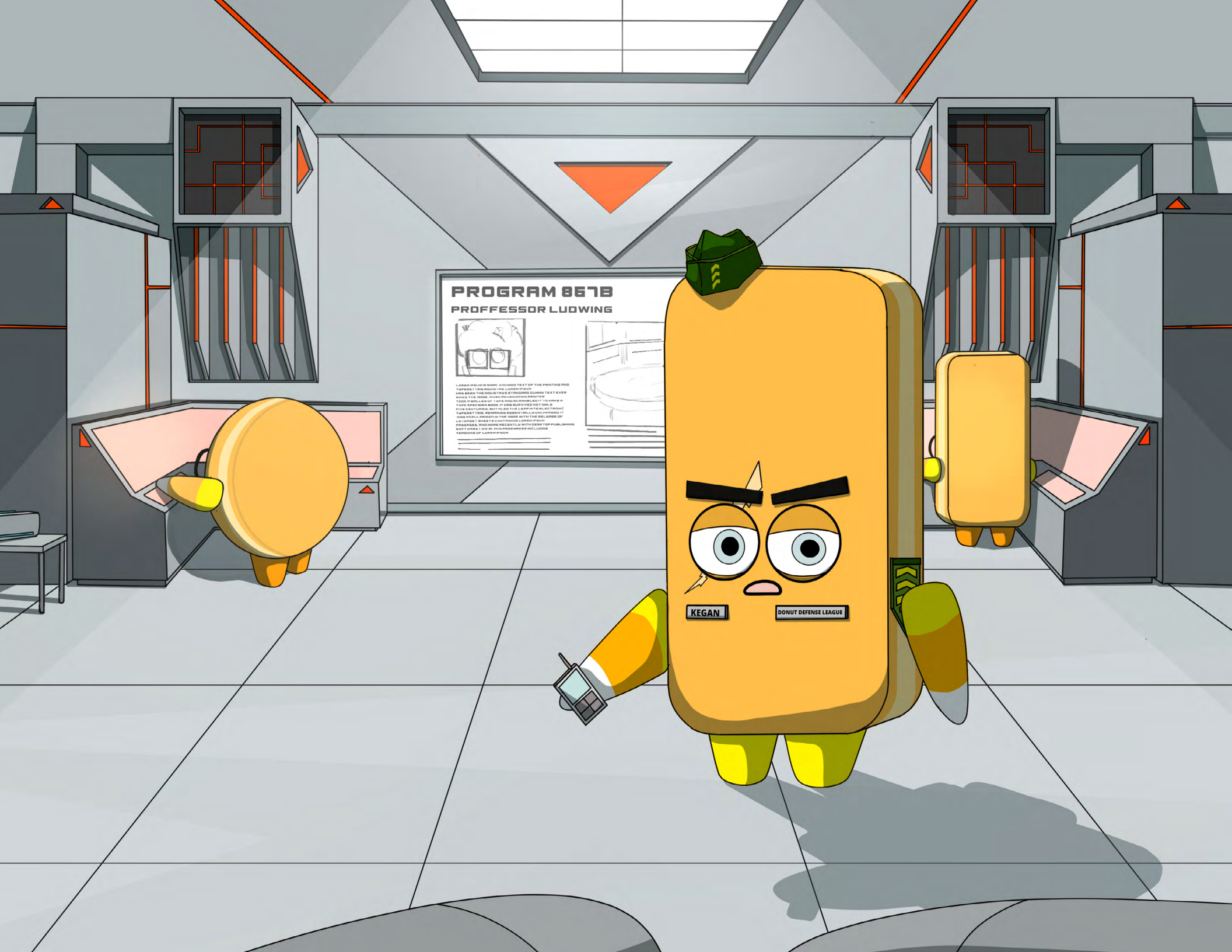

PROGRAM 867B
PROFESSOR LUDWIG



LUDWIG WAS BORN IN GERMANY IN 1945. HE WAS A MEMBER OF THE NAZI PARTY AND SERVED IN THE ARMY DURING THE SECOND WORLD WAR. HE WAS A MEMBER OF THE NAZI PARTY AND SERVED IN THE ARMY DURING THE SECOND WORLD WAR. HE WAS A MEMBER OF THE NAZI PARTY AND SERVED IN THE ARMY DURING THE SECOND WORLD WAR.

KEGAN

DONUT DEFENSE LEAGUE

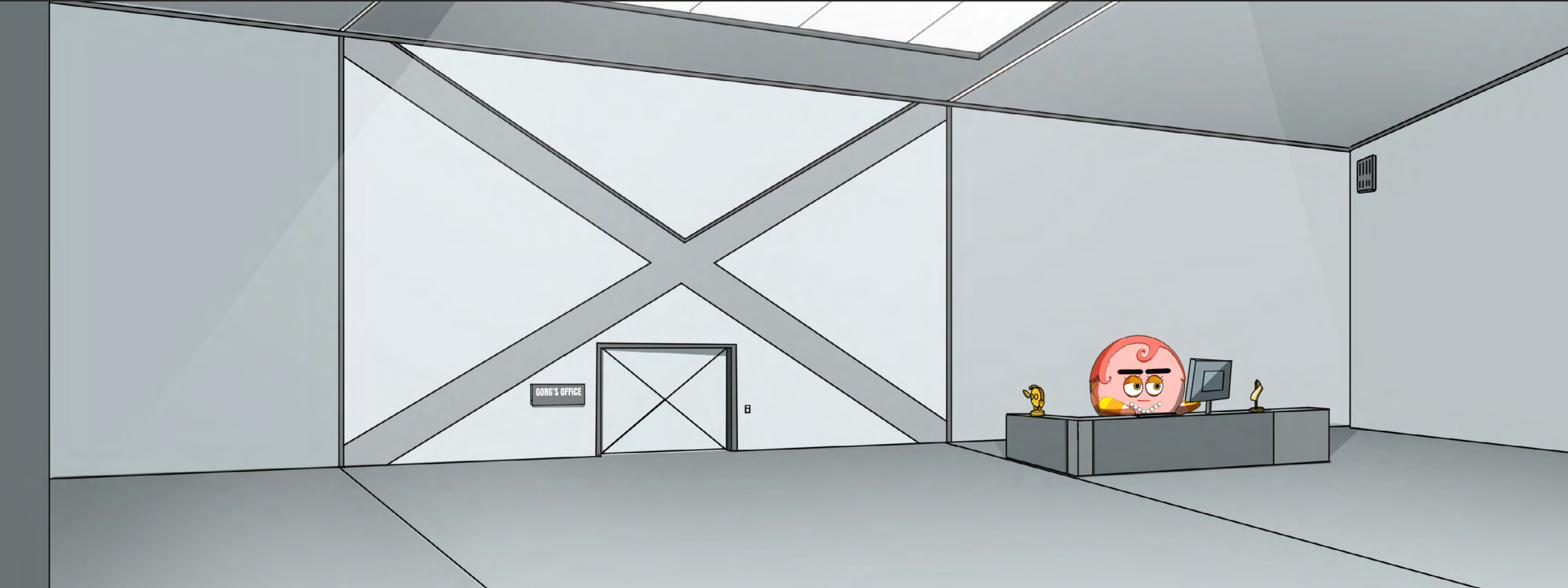
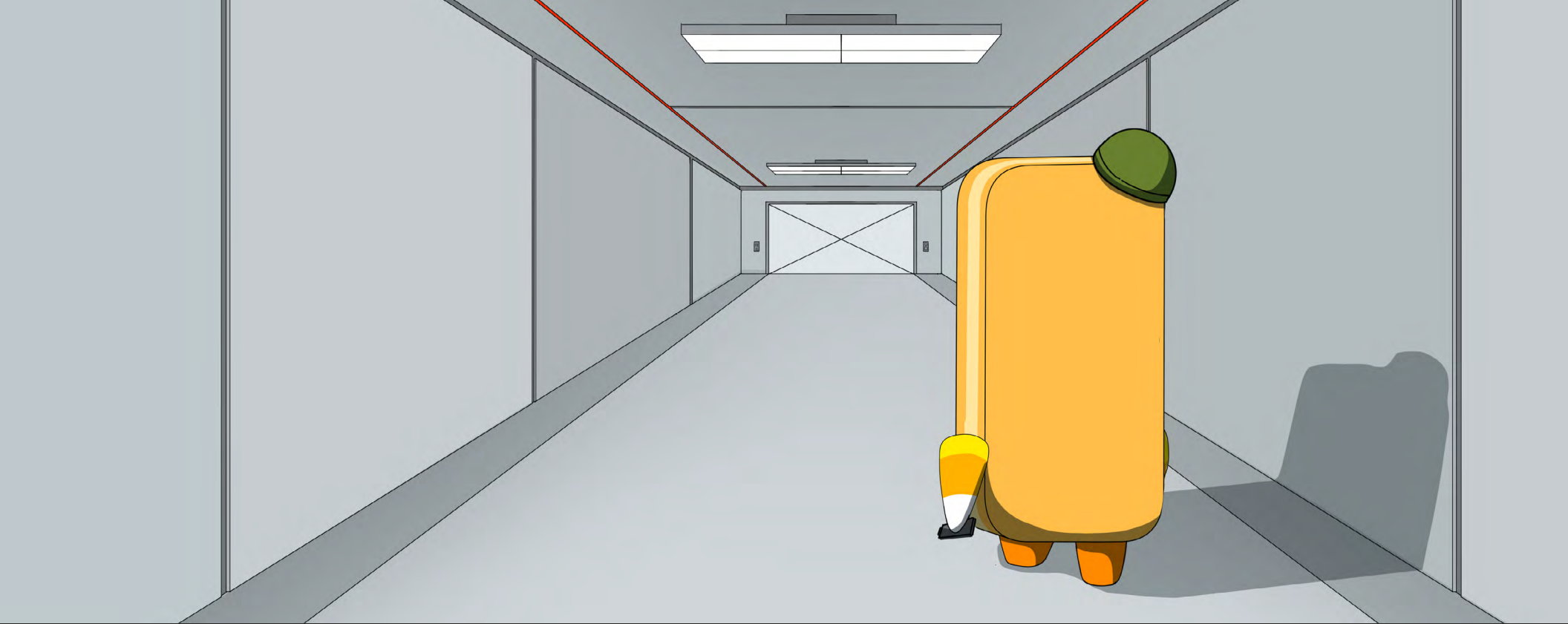







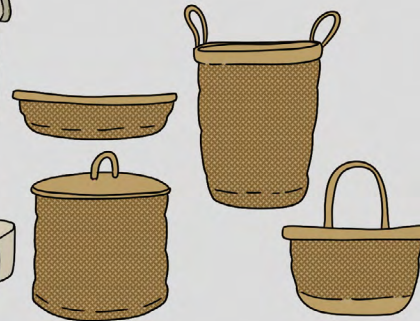
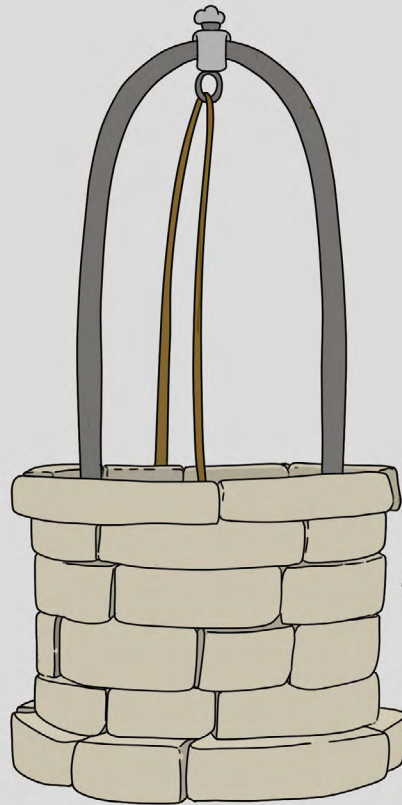
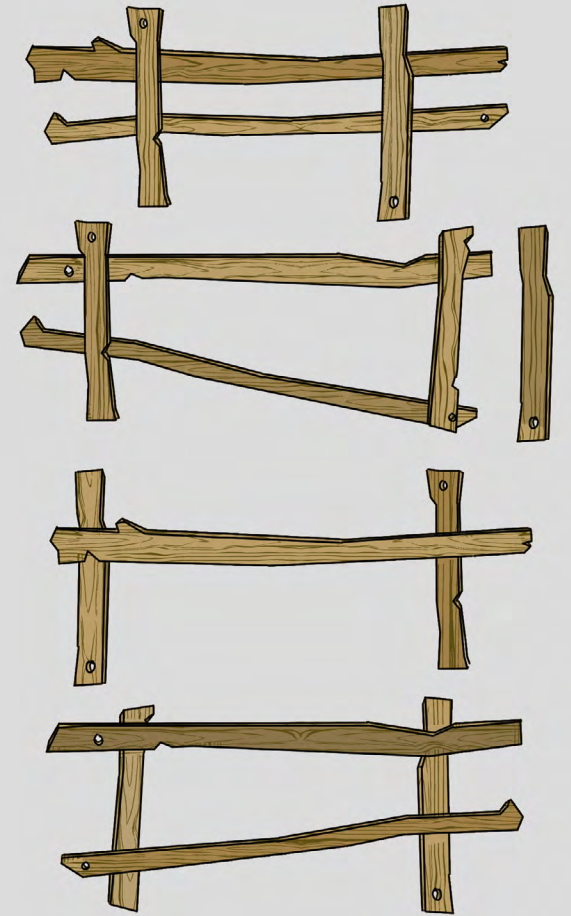
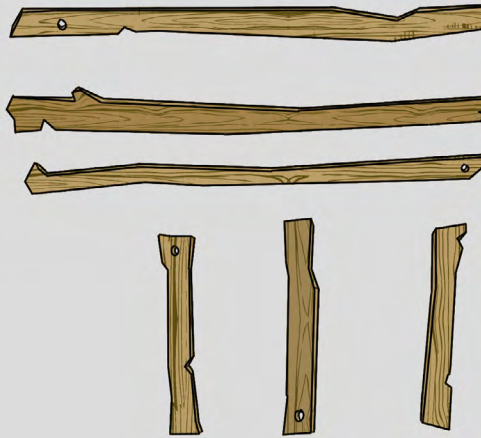
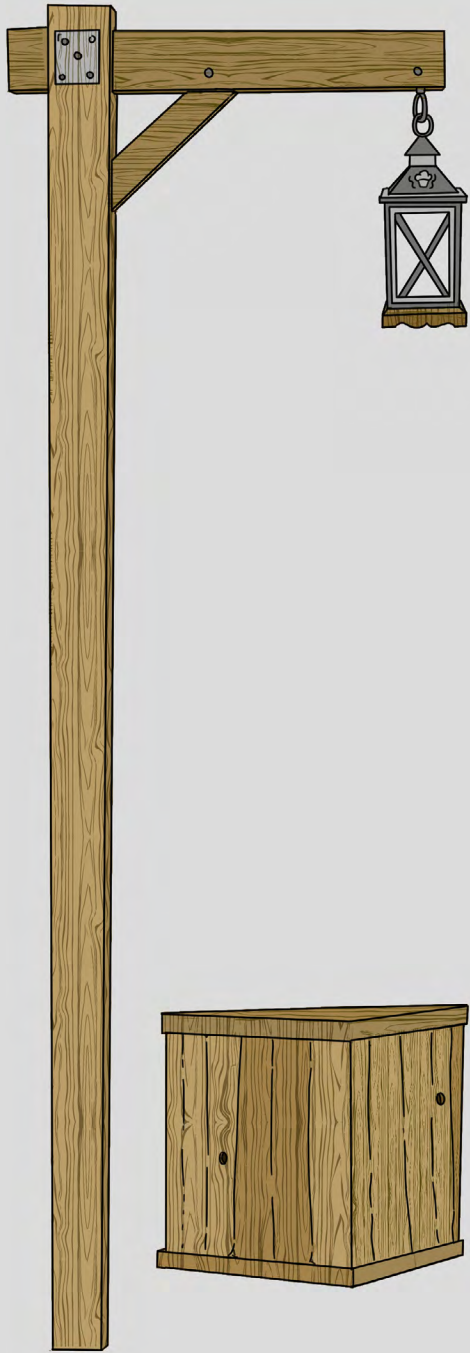



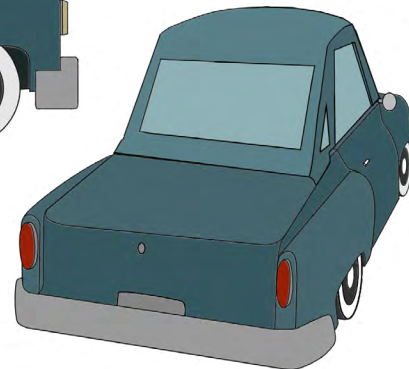
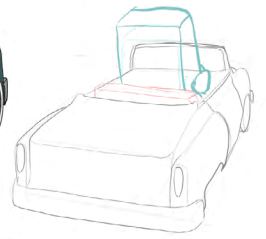
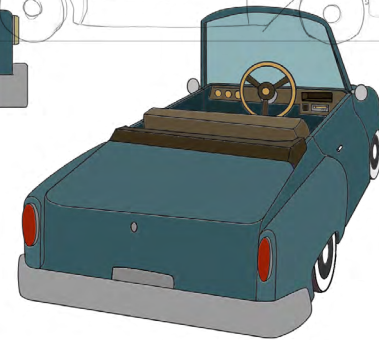
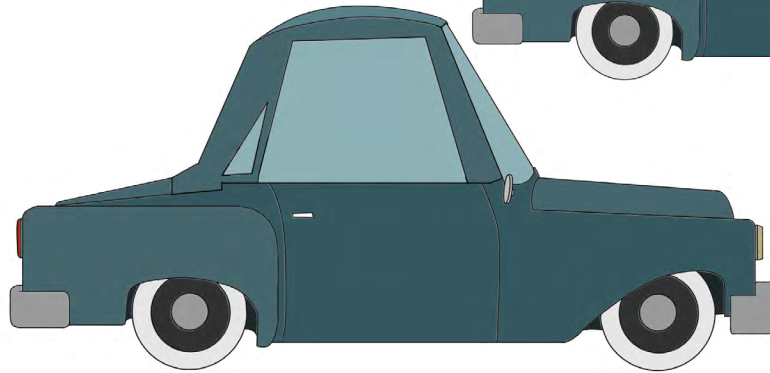
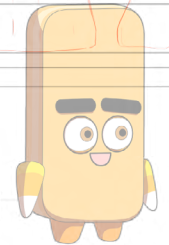
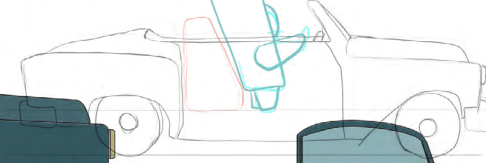
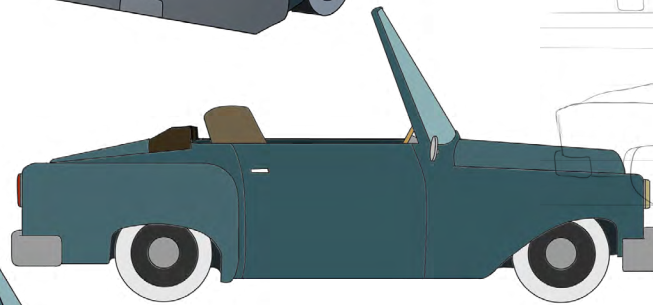
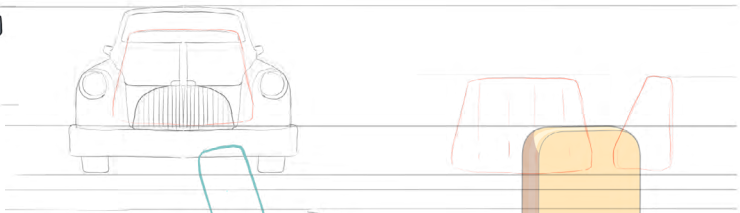
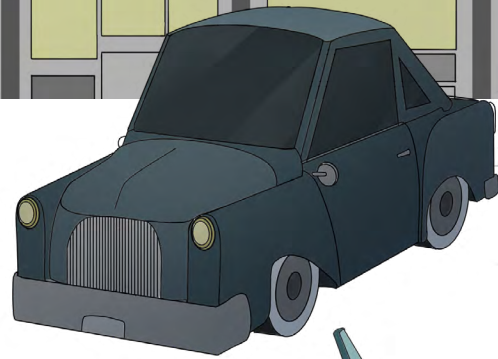
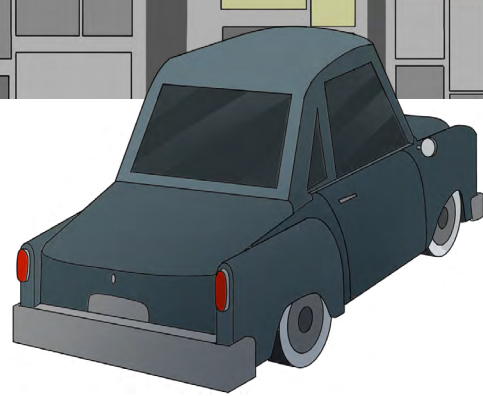





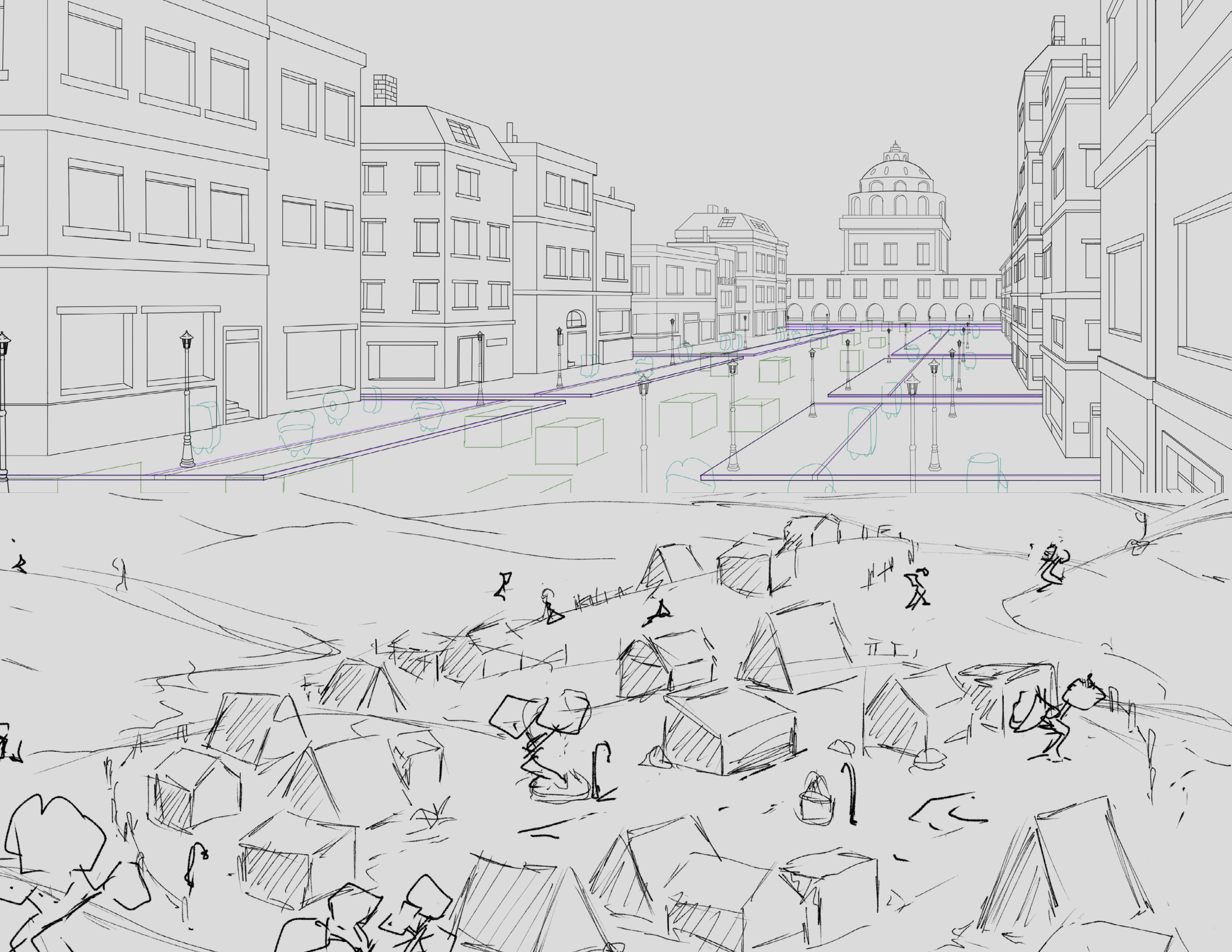

TIME PERIOD / MEDIUM / PLACE "X"
BUILDING ART
#1B5

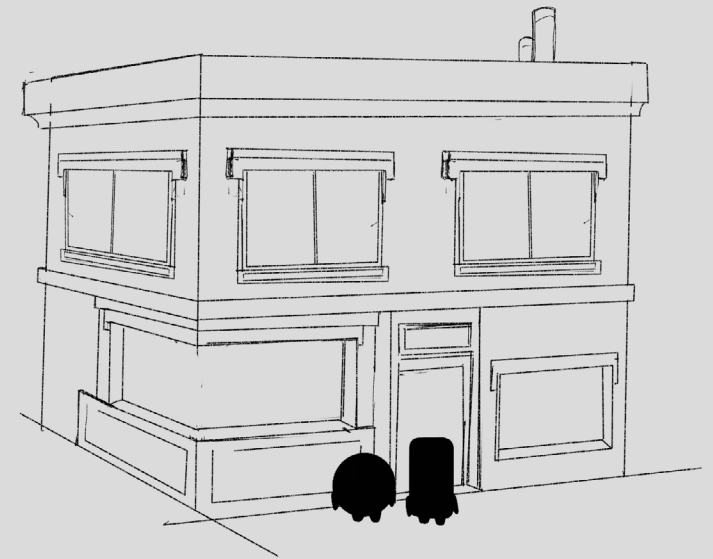
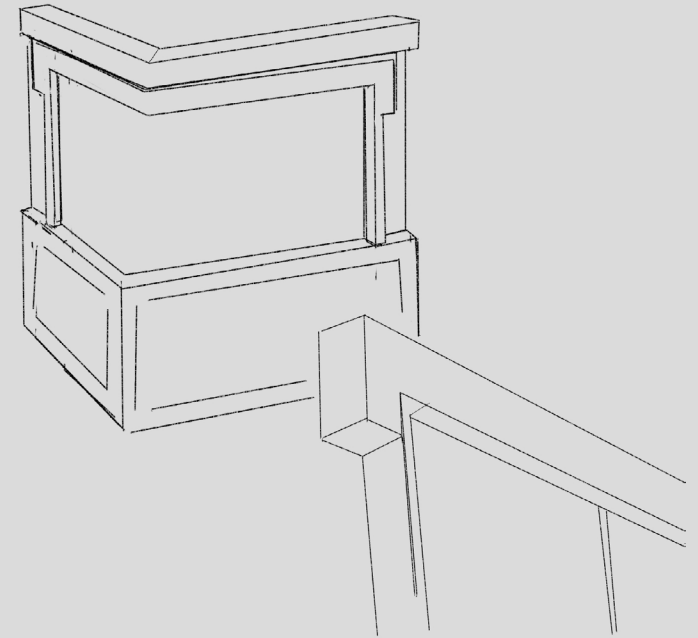
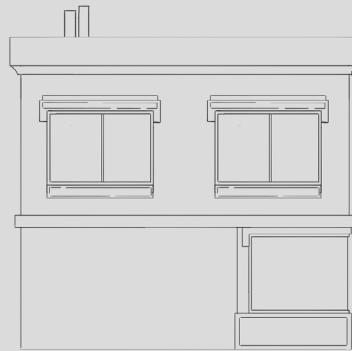
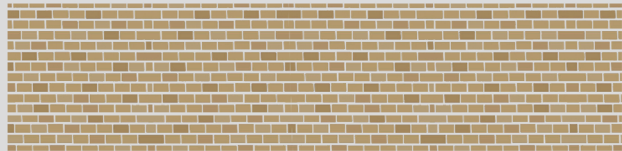

TIME PERIOD / MEDIUM / PLACE "X"
BUILDING ART
#1B1

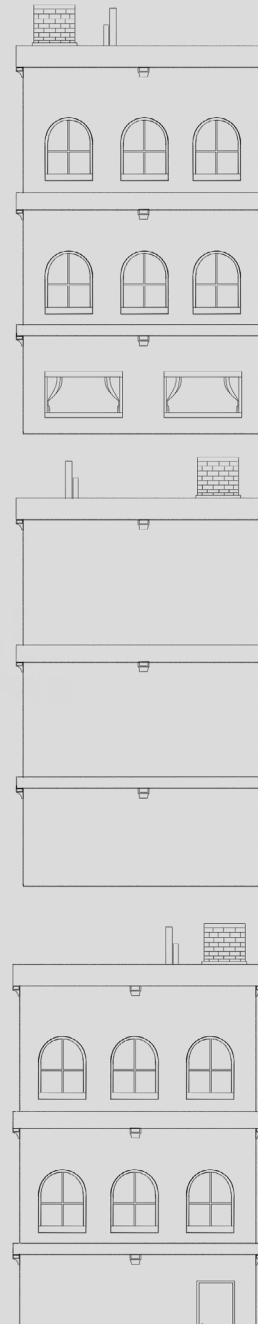
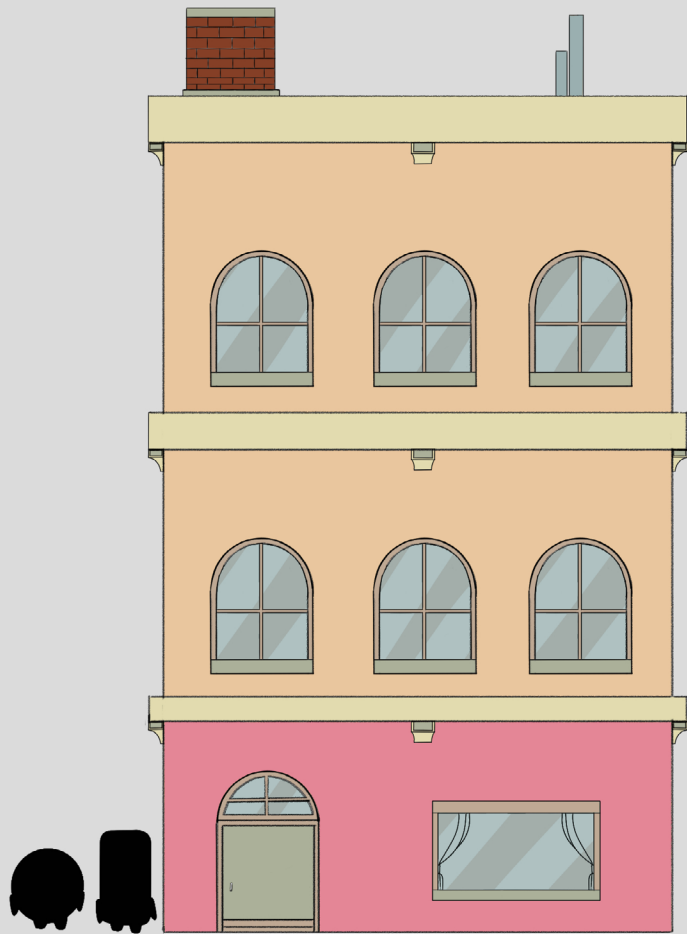

TIME PERIOD / MEDIUM / PLACE "X"
BUILDING ART
#1B2

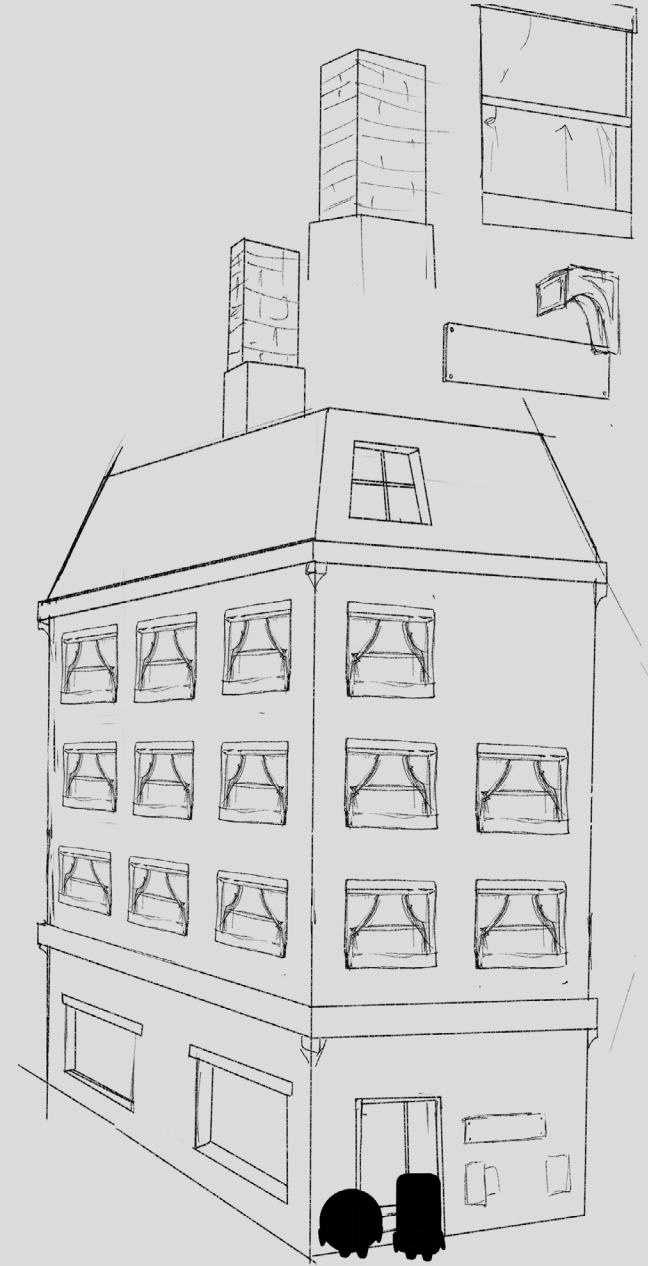
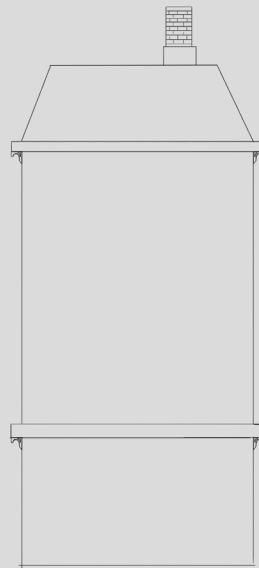
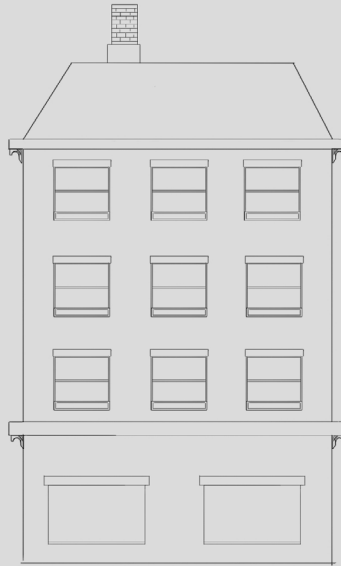
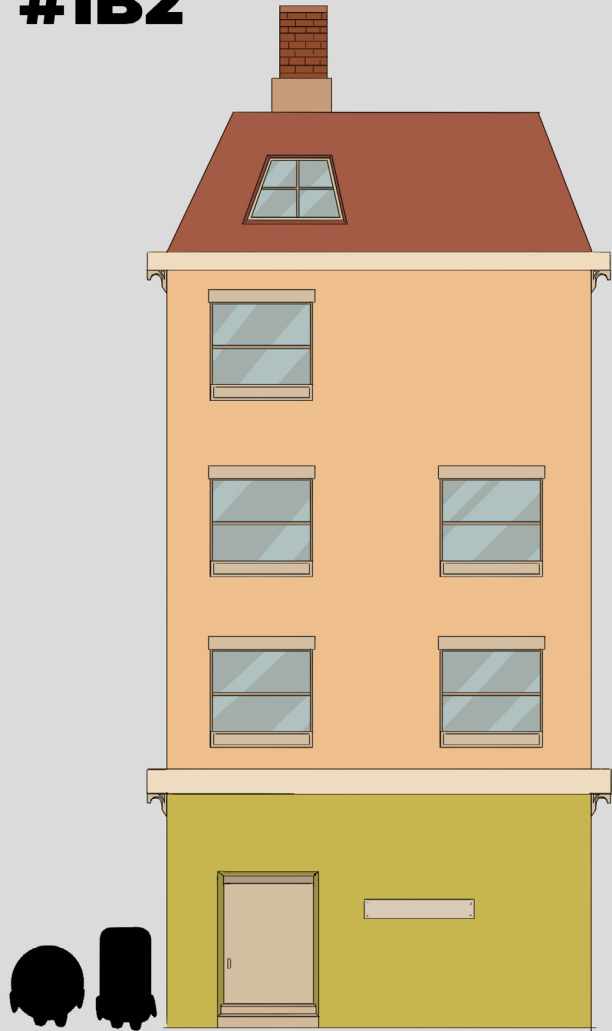

TIME PERIOD / MEDIUM / PLACE "X"
BUILDING ART
#1B4

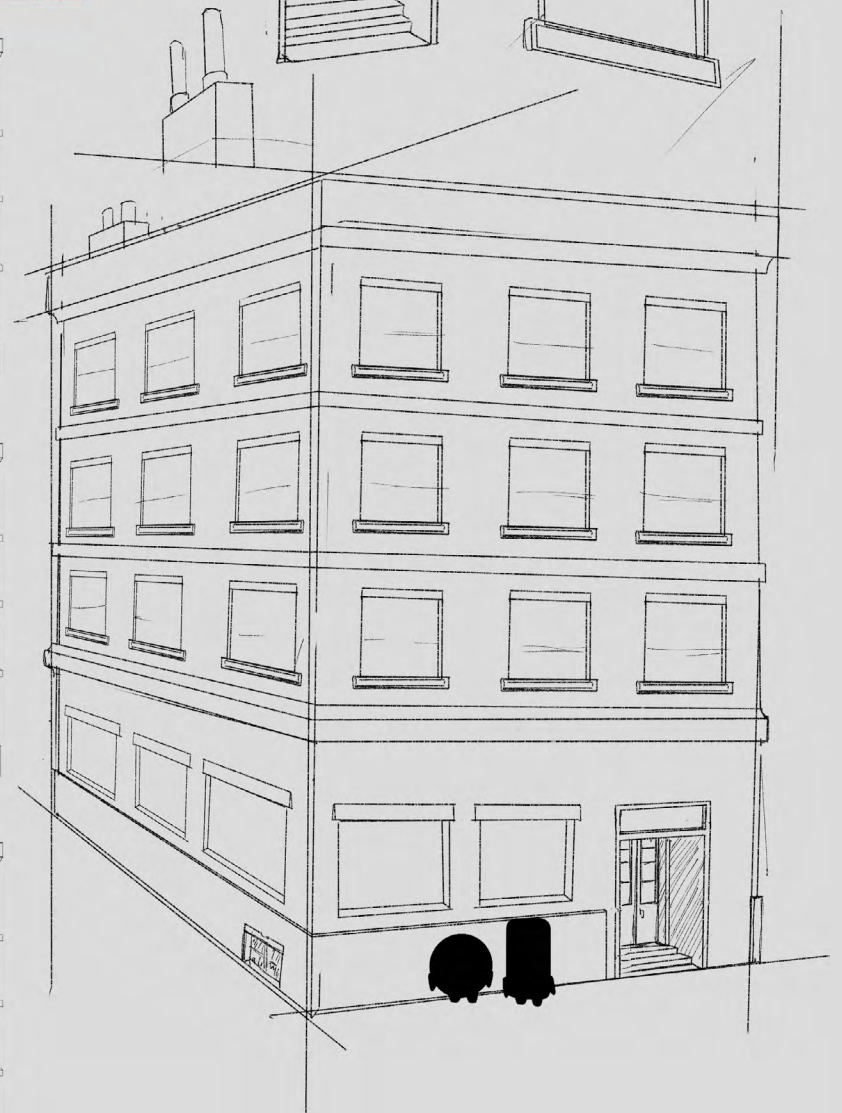
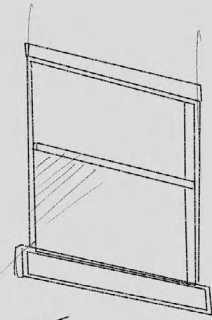
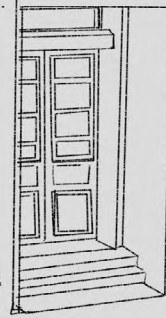
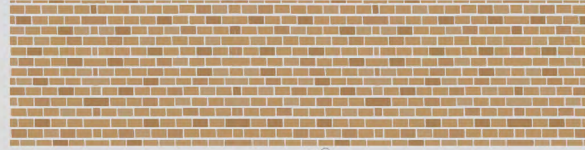

TIME PERIOD / MEDIUM / PLACE "X"
BUILDING ART
#1B3

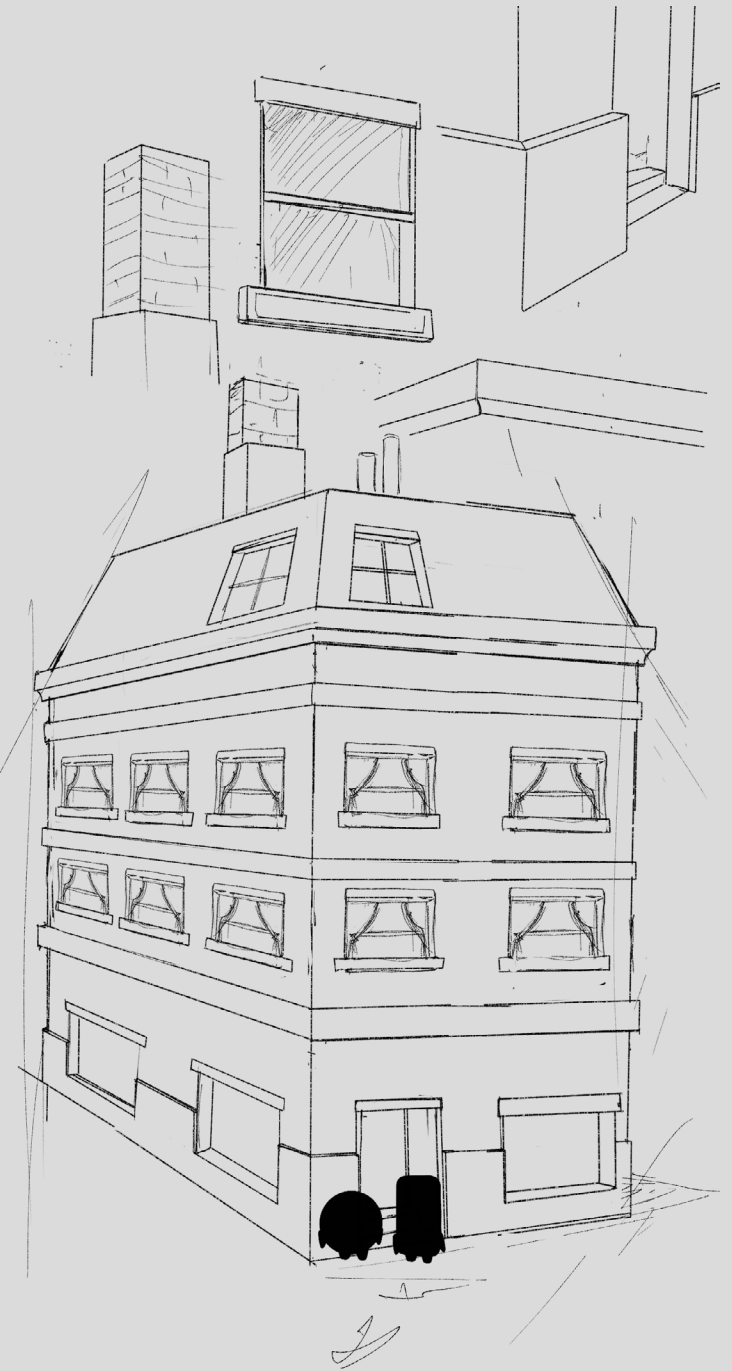

TIME PERIOD / MEDIUM / VILLAGE MUFFIN
BUILDING ART
#2B4

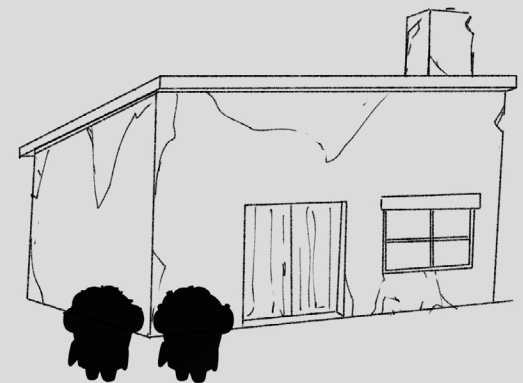
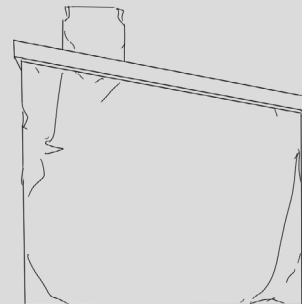
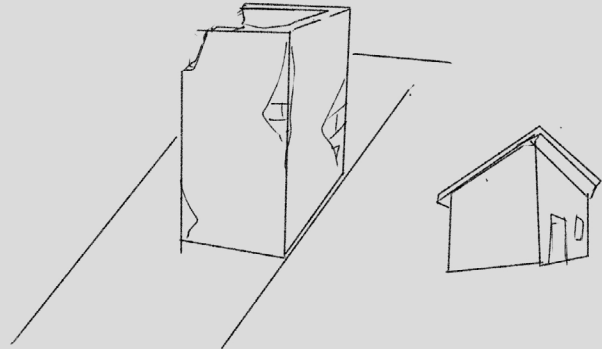
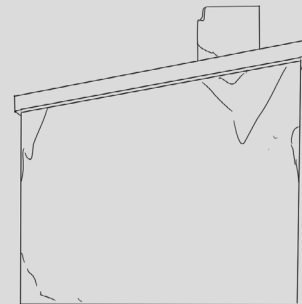
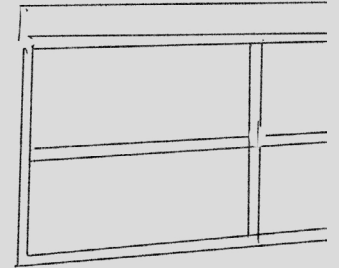
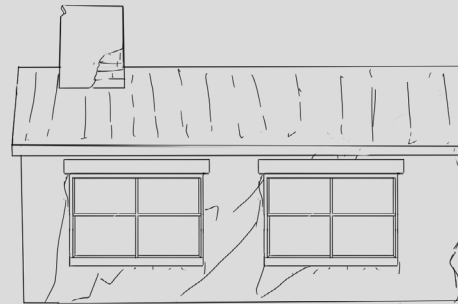

**TIME PERIOD / MEDIUM / VILLAGE MUFFIN
BUILDING ART
#2B3**

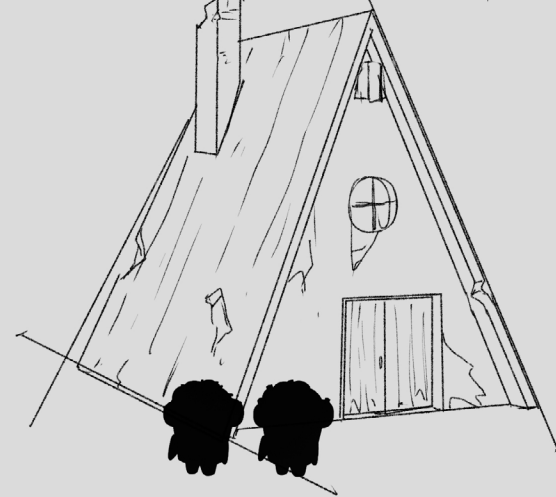
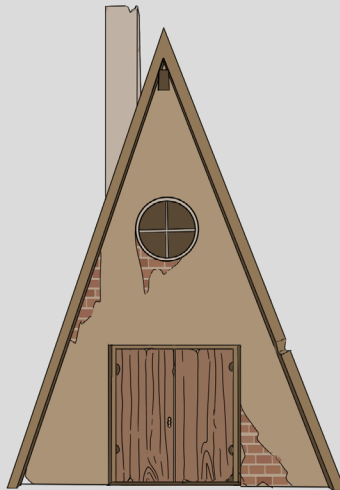
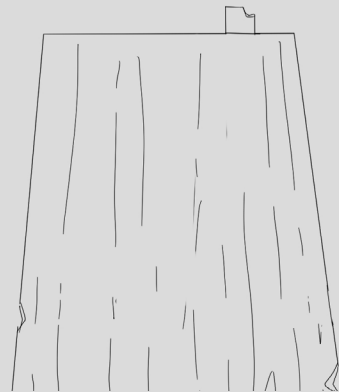
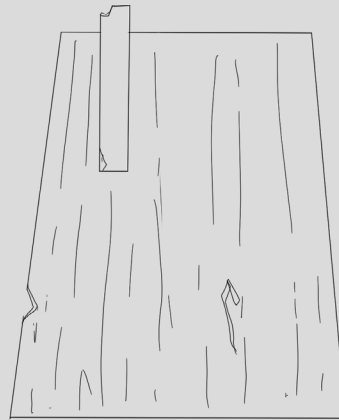
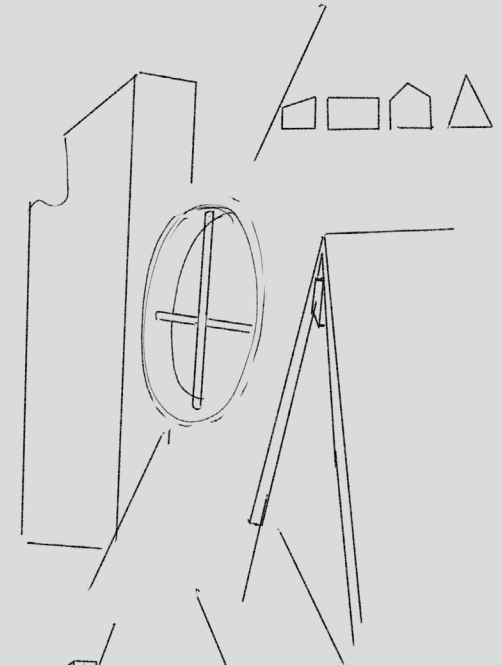
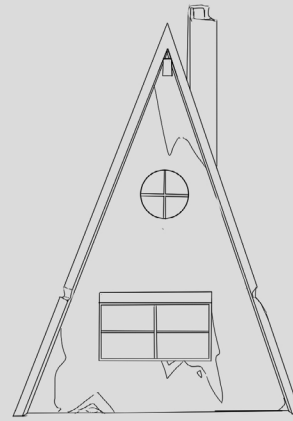

**TIME PERIOD / MEDIUM / VILLAGE MUFFIN
BUILDING ART**

#2B2

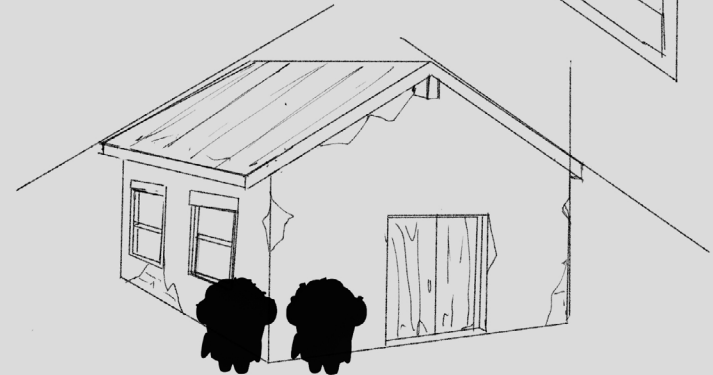
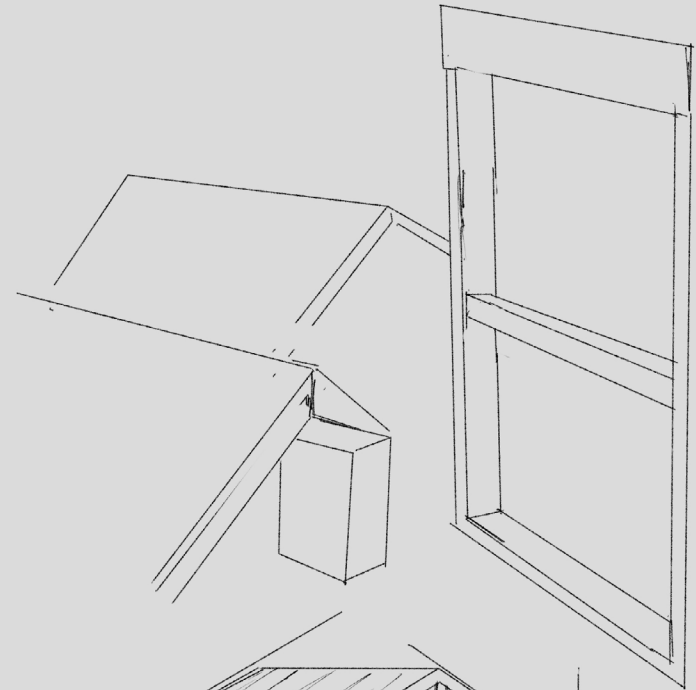
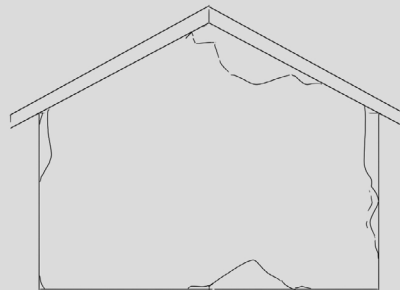
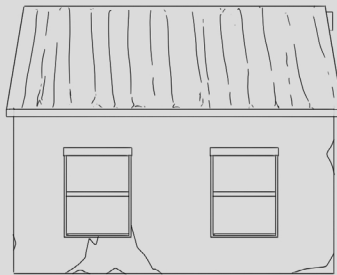
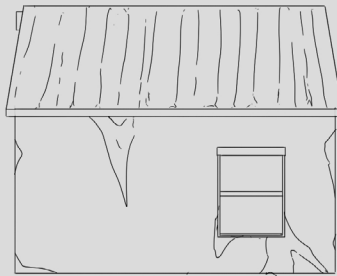
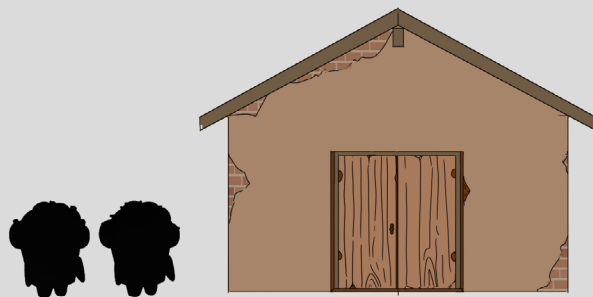

TIME PERIOD / MEDIUM / VILLAGE MUFFIN
BUILDING ART
#2B1

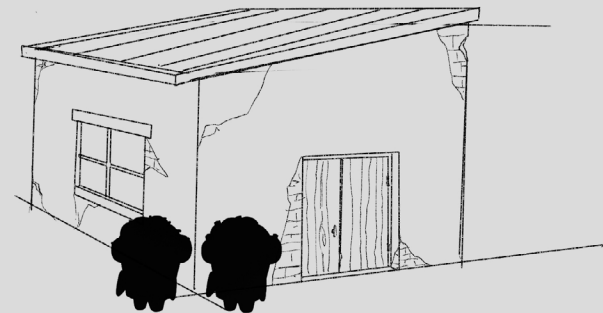
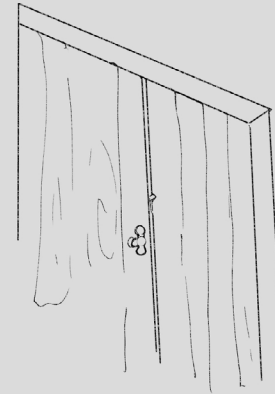
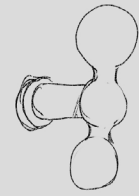
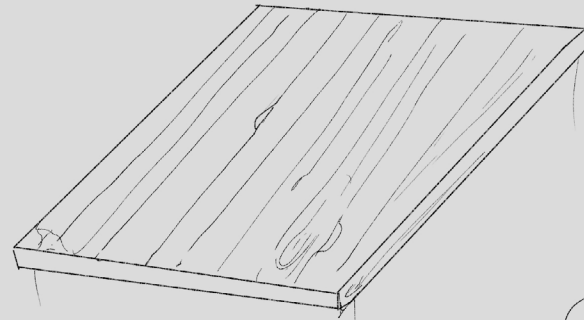
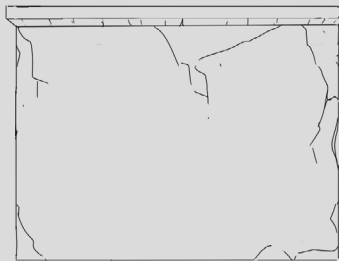
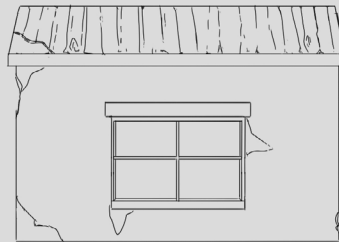
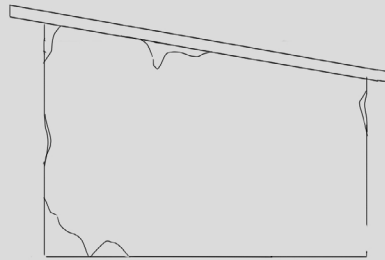
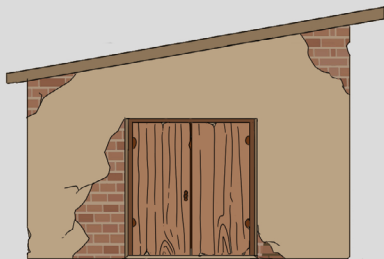





**SUPER AWESOME
ADVENTURE
CANDYLAND**
THE MOST AWESOME SUPER
AWESOME PLACE IN ALL OF EVERYWHERE

**SUPER AWESOME ADVENTURE
CANDYLAND**

**ENTER
HERE**

WELCOME

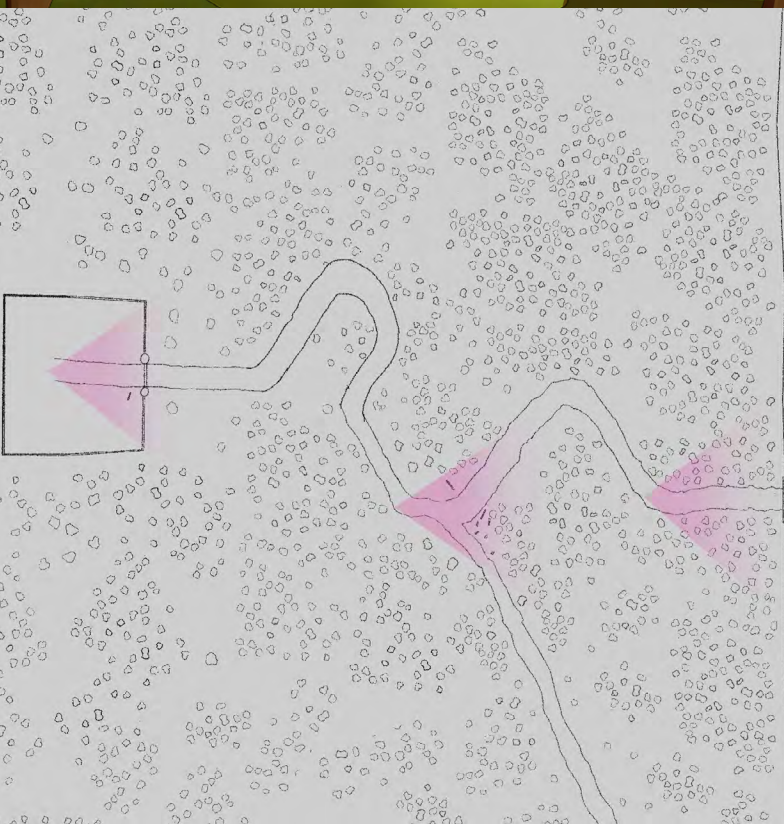



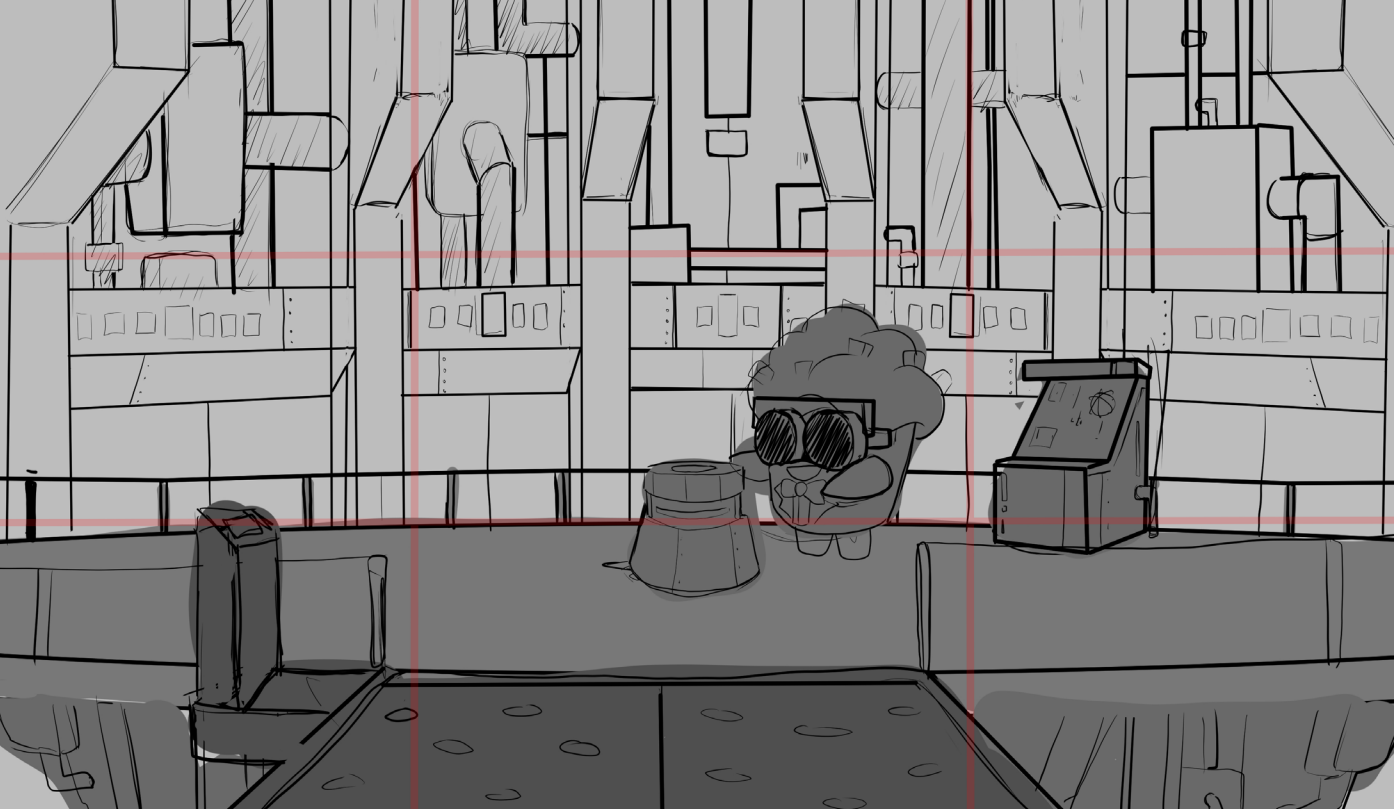



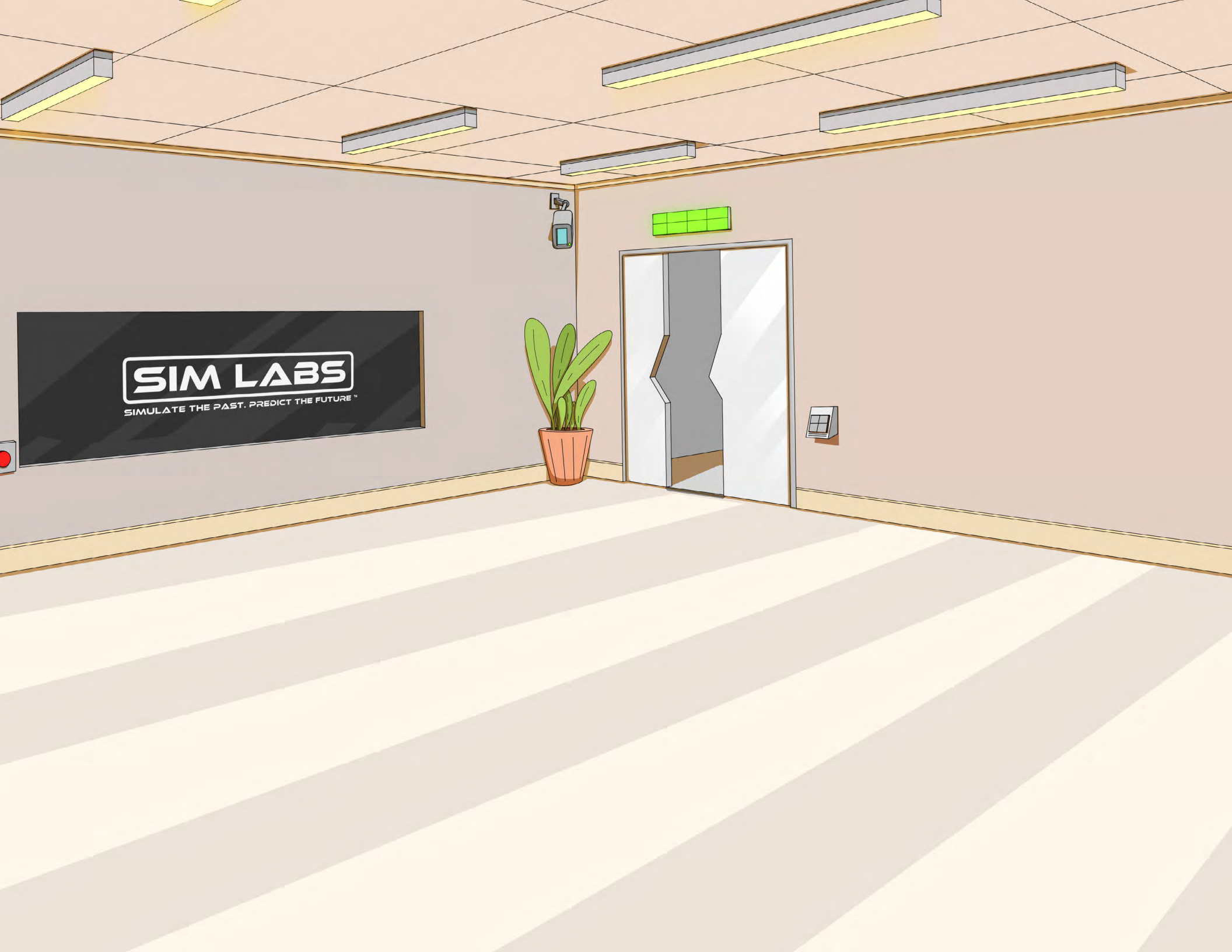
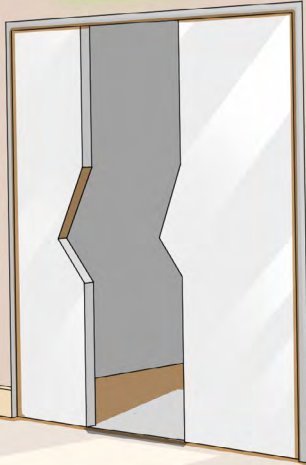
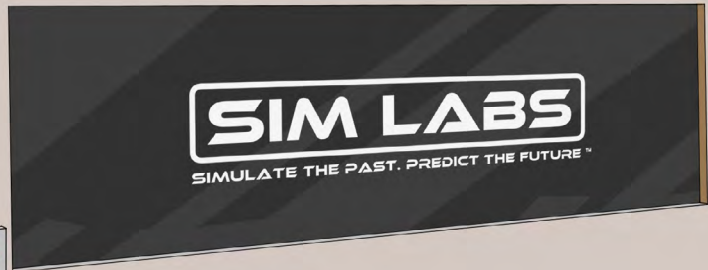

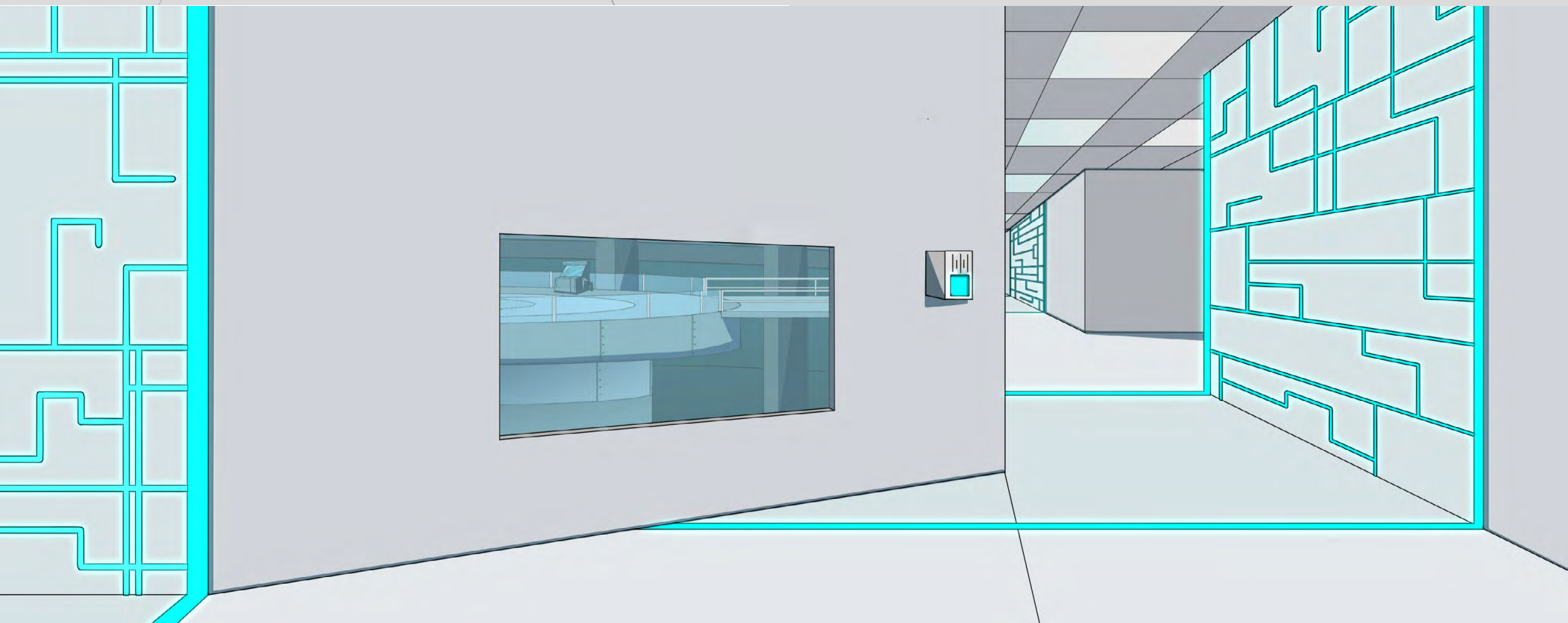



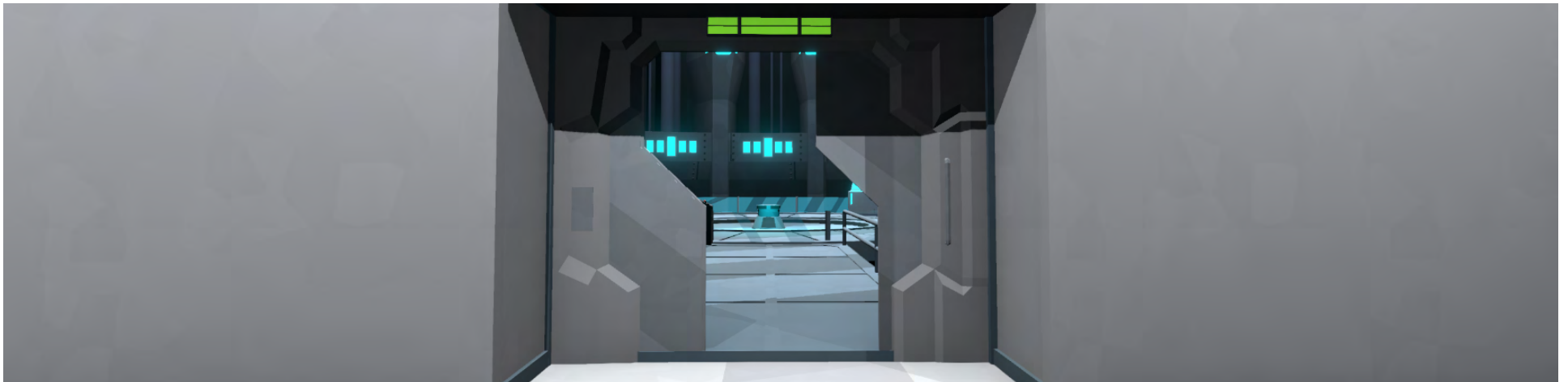
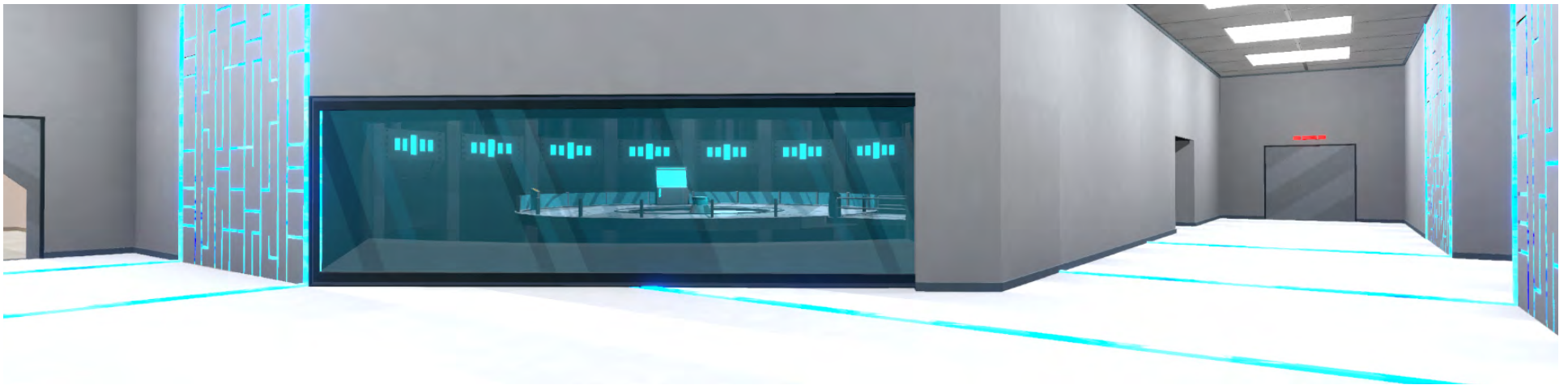
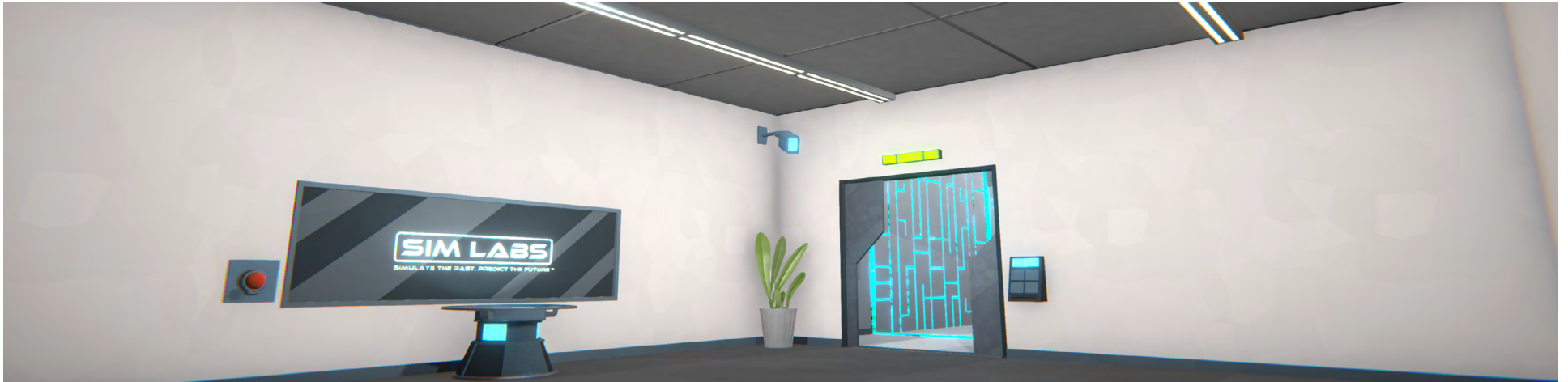

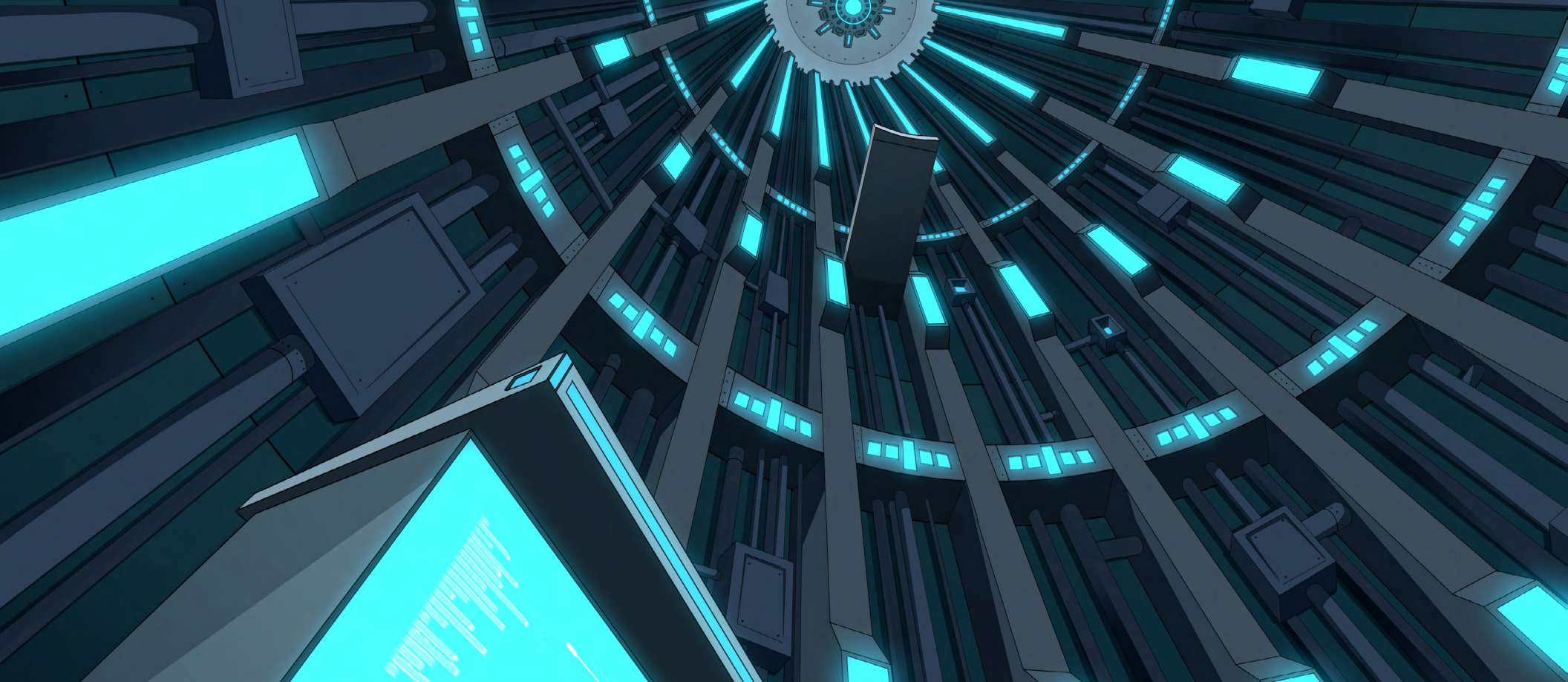
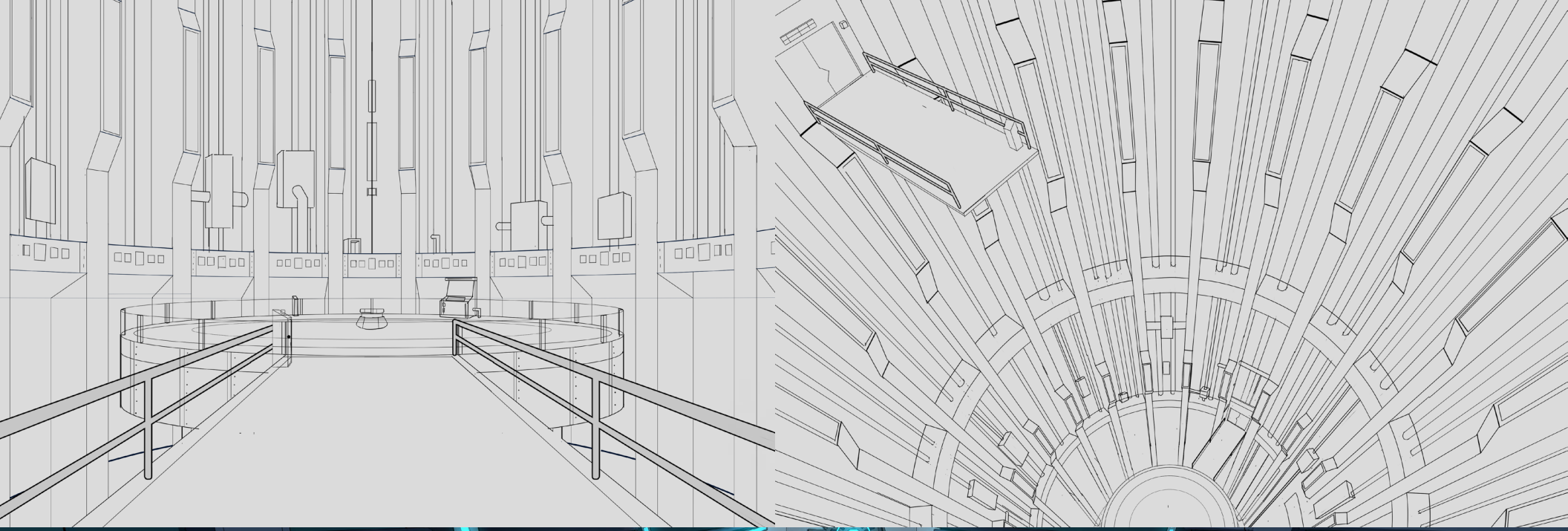



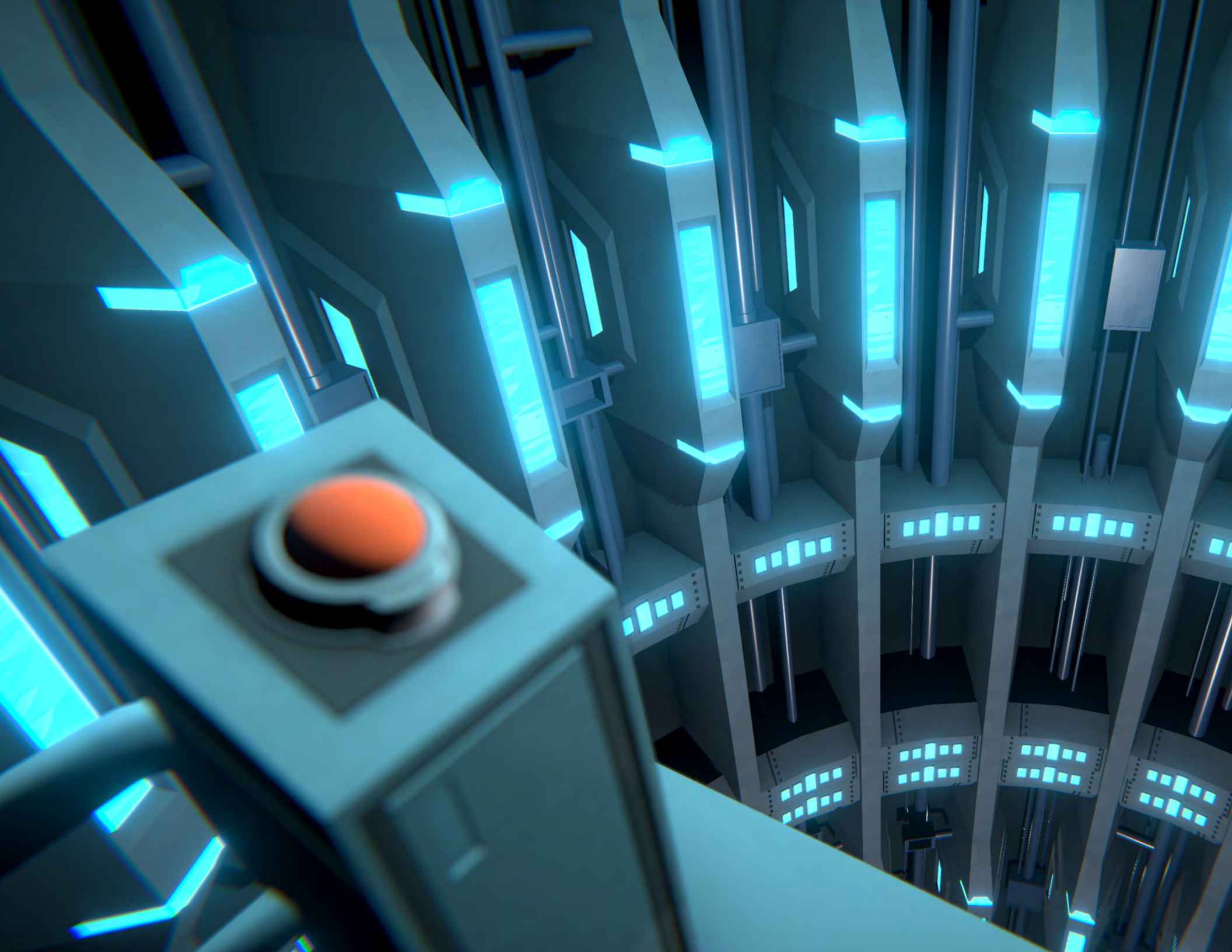

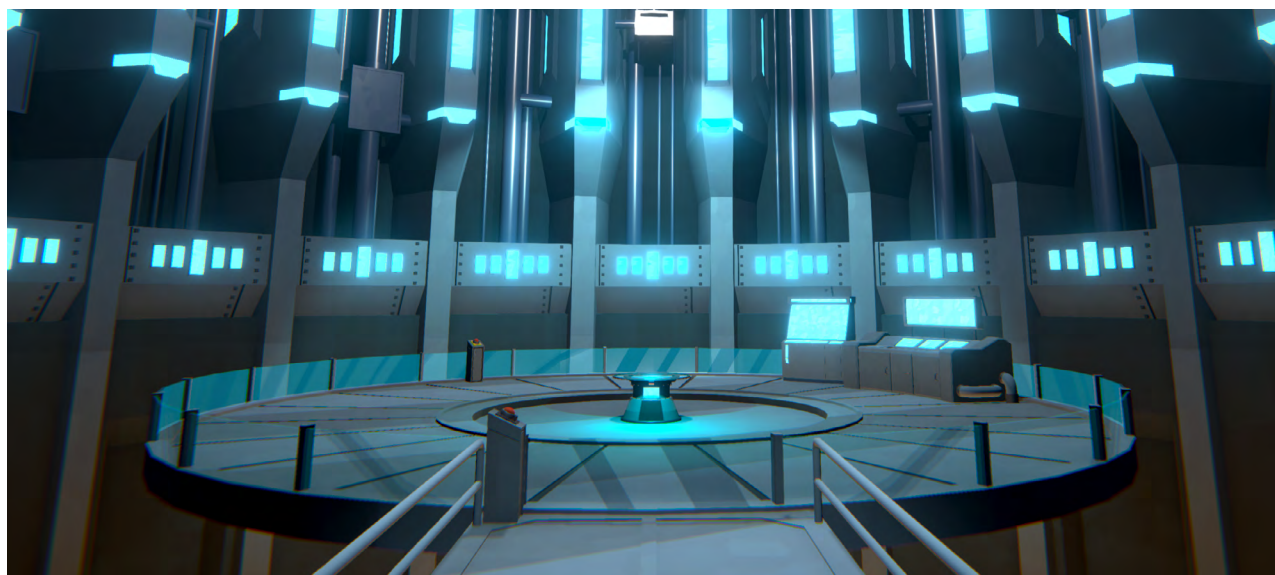
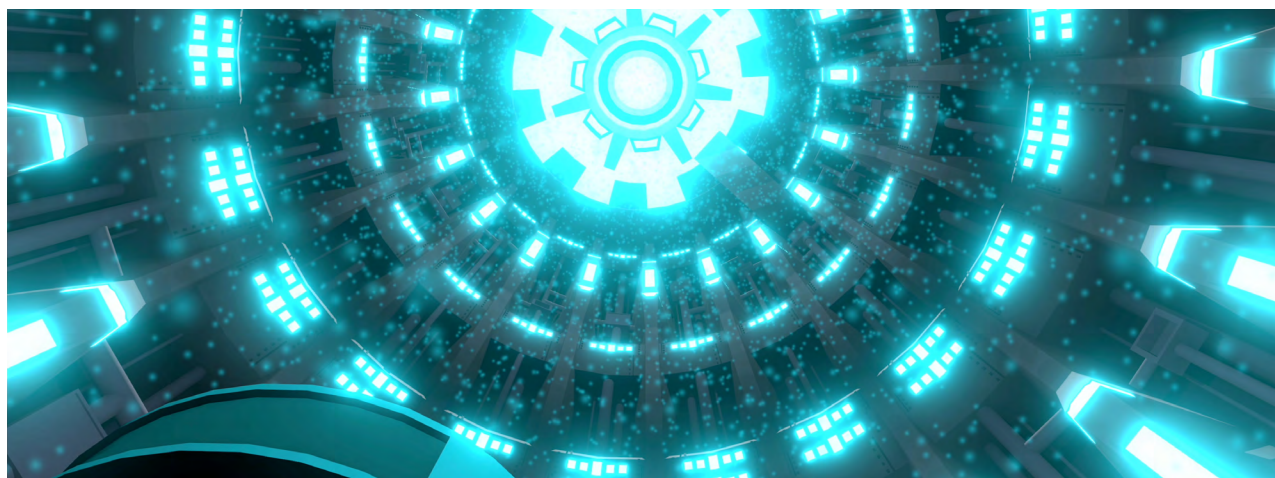
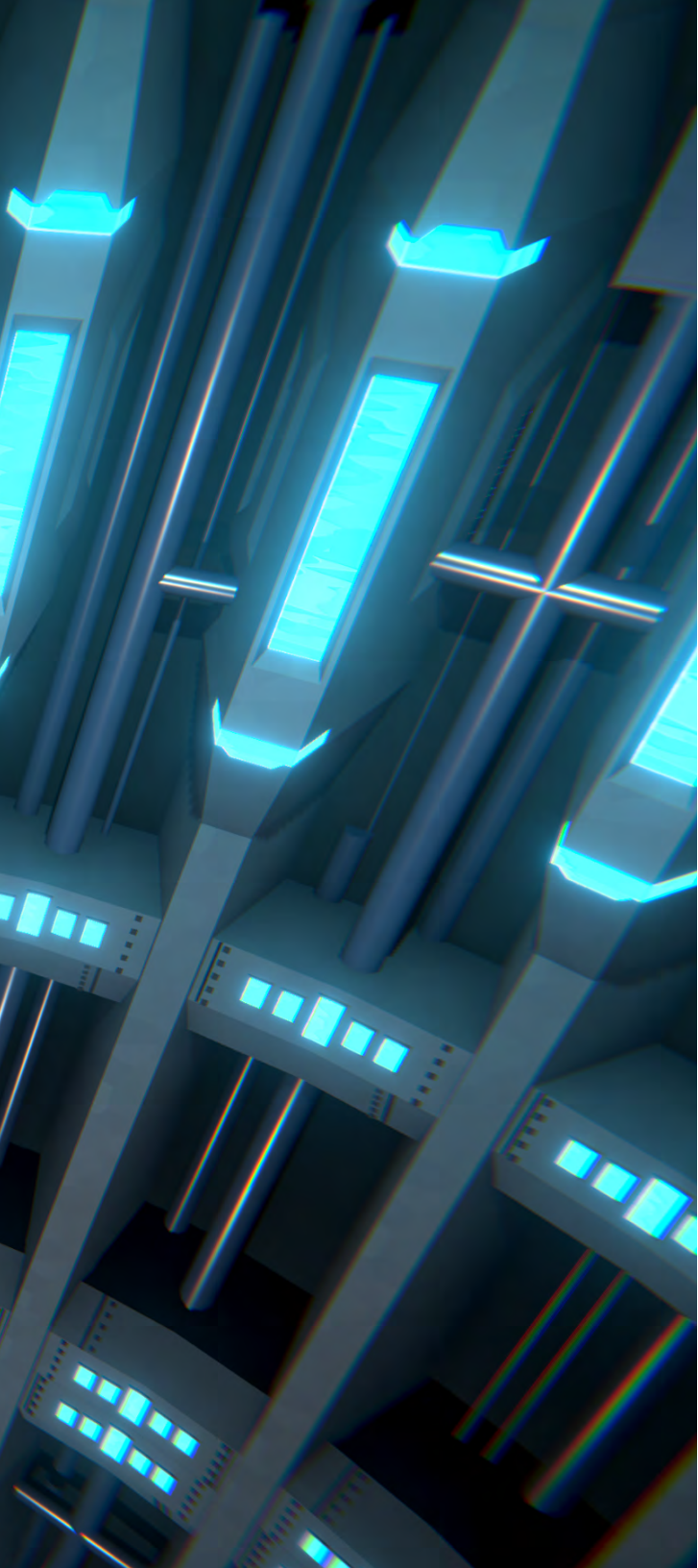

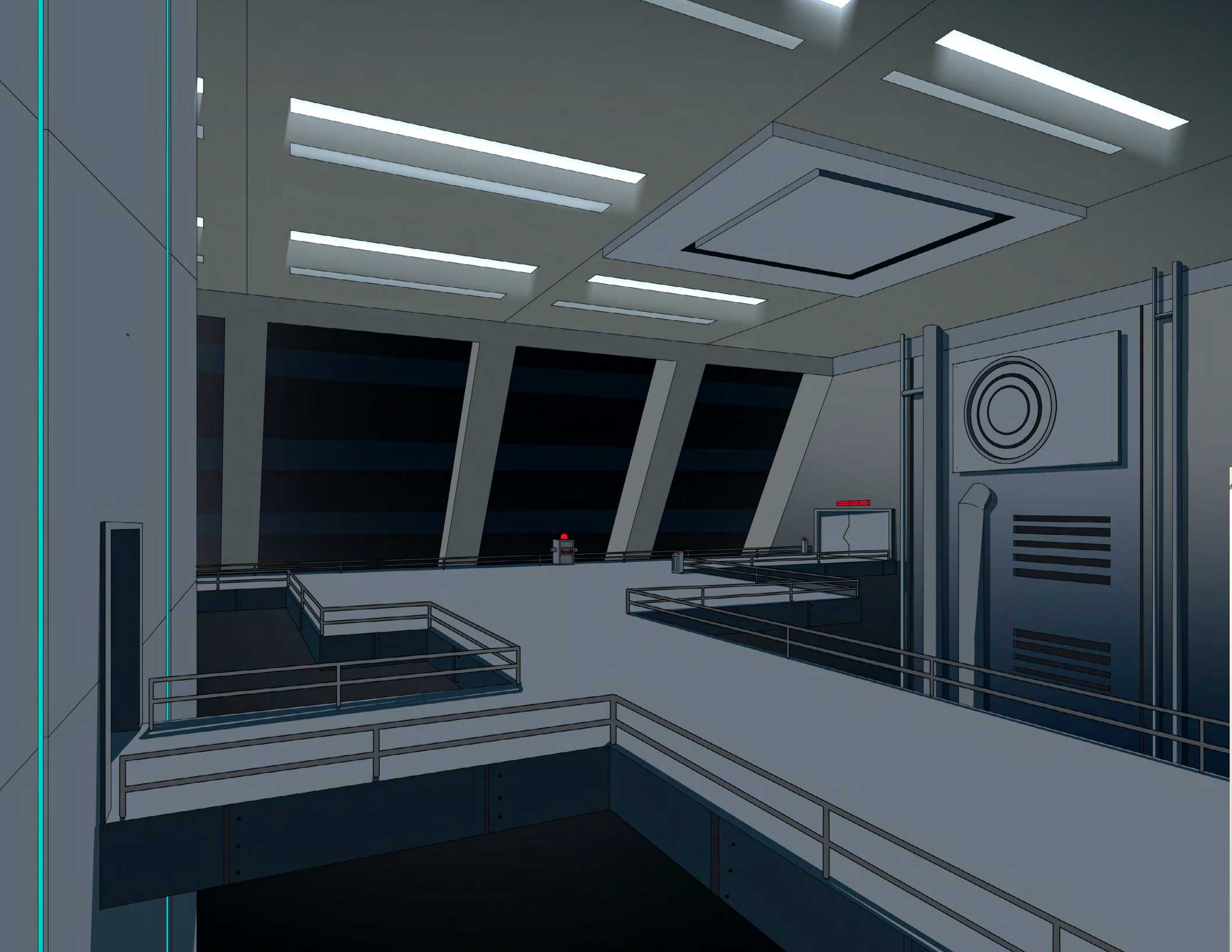

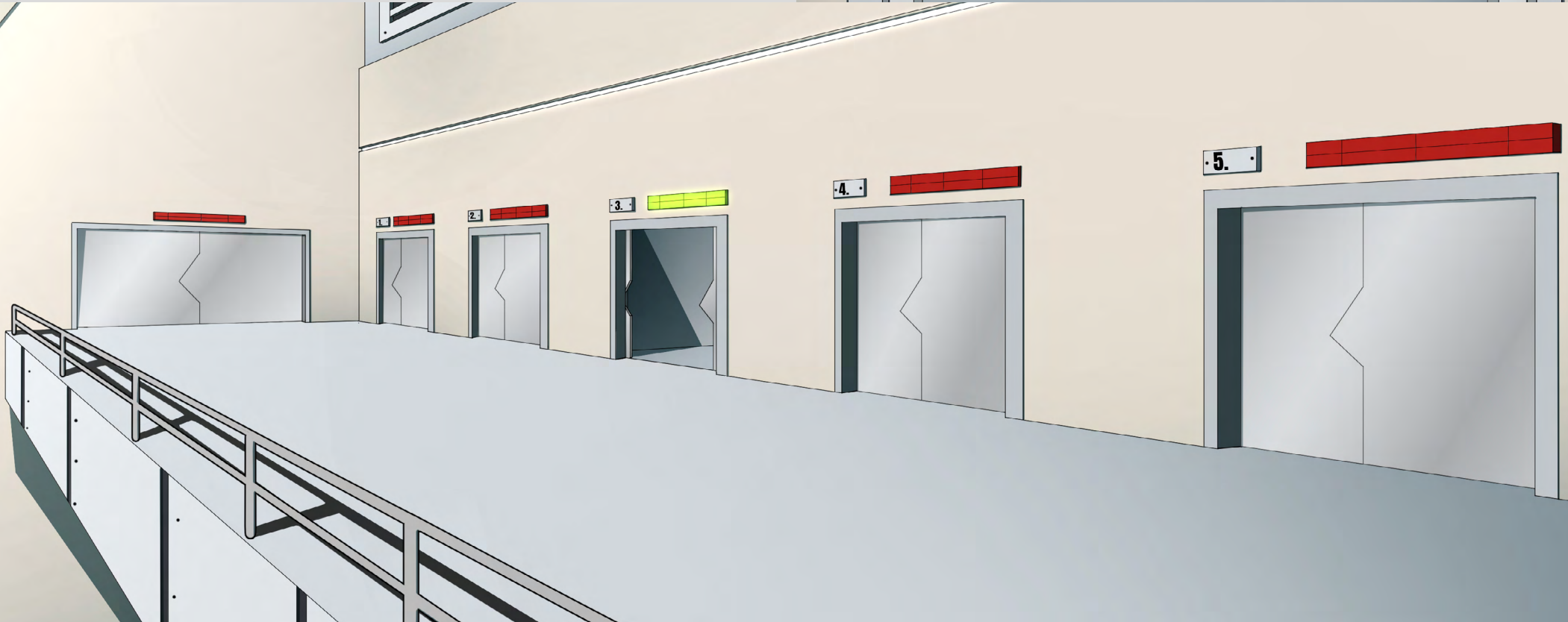
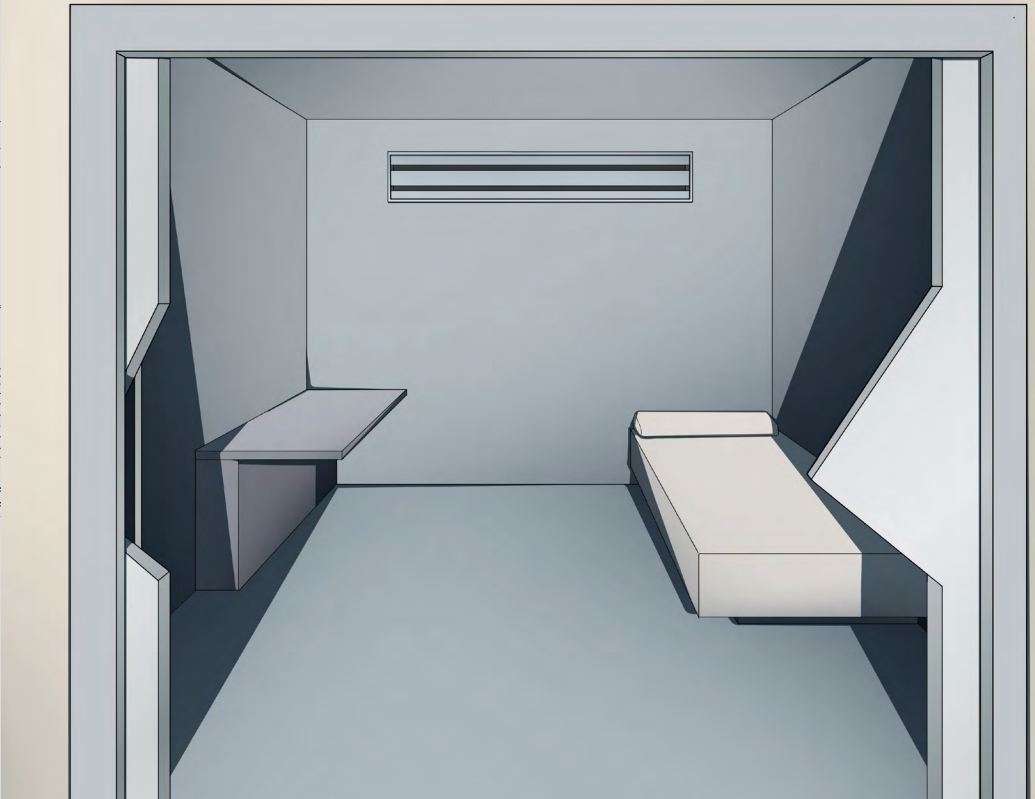
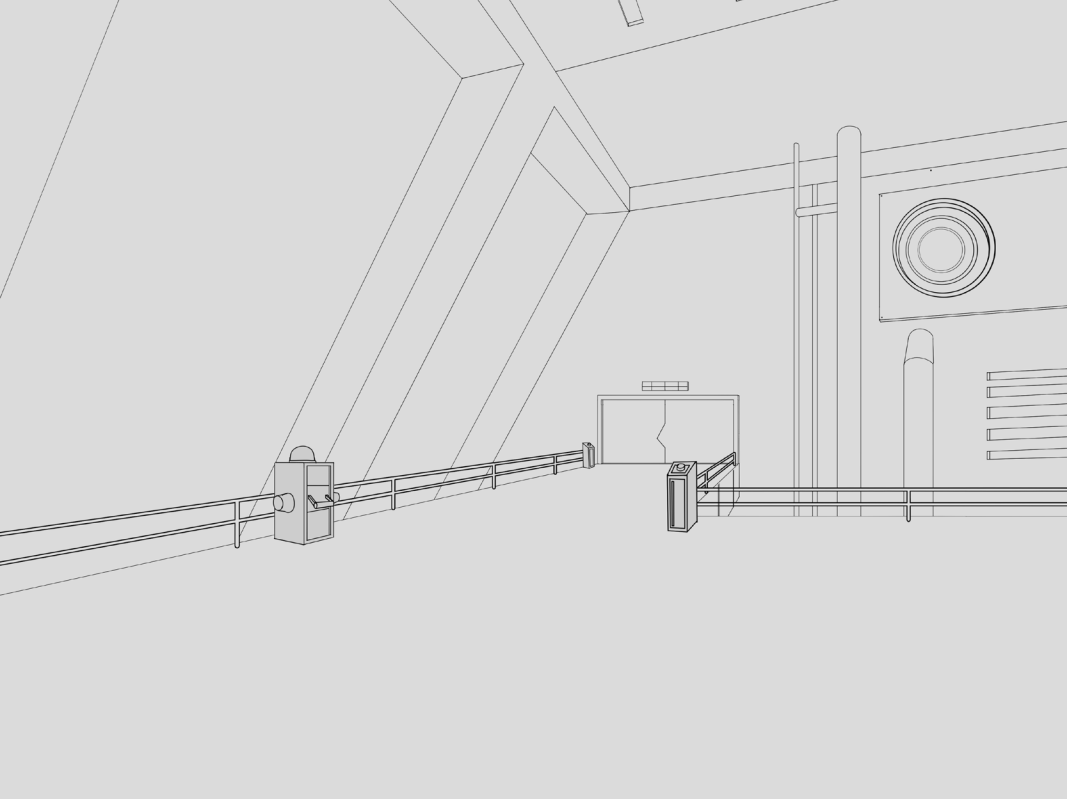

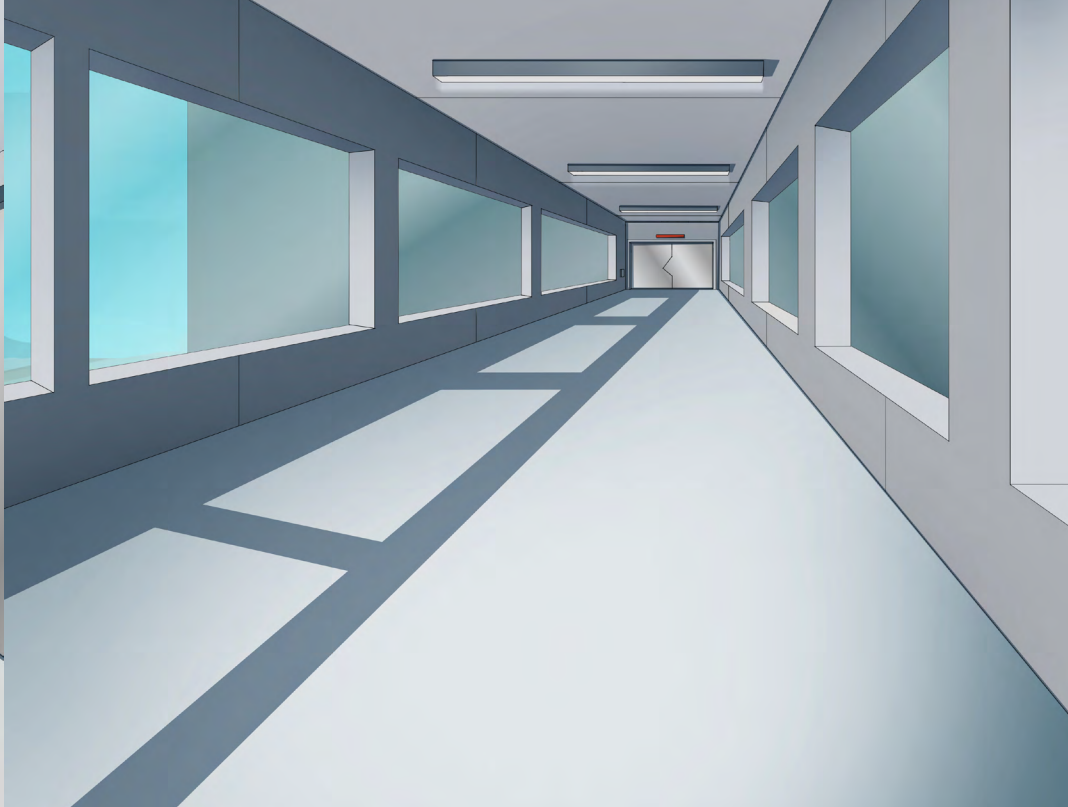

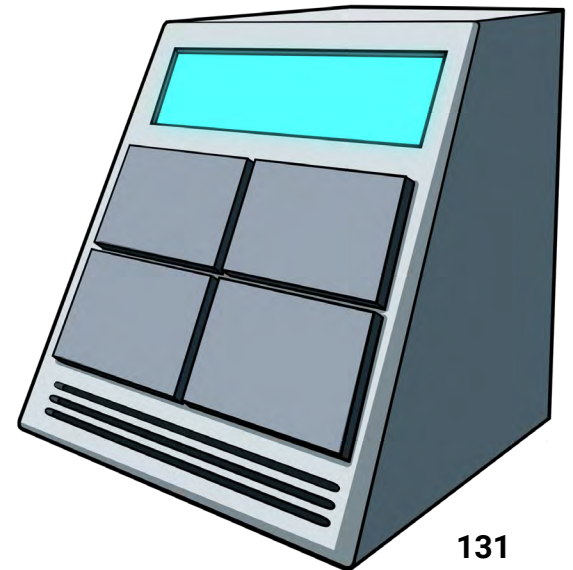
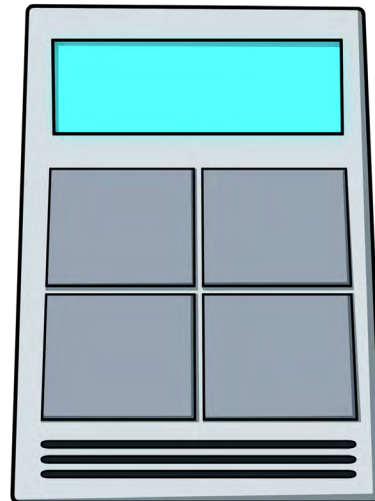
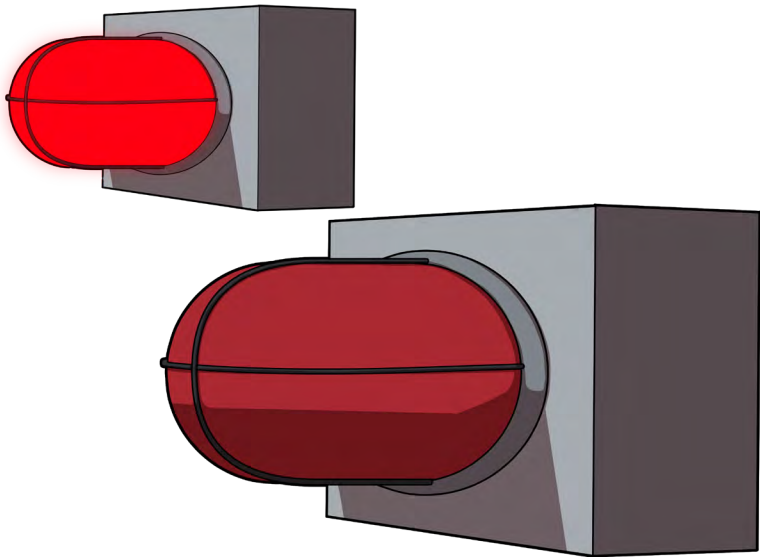
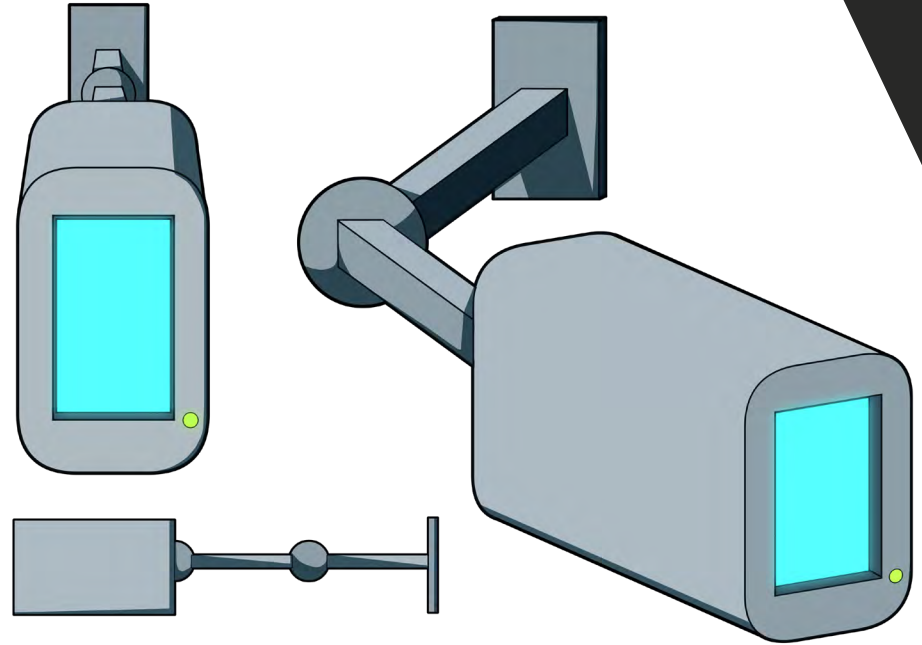
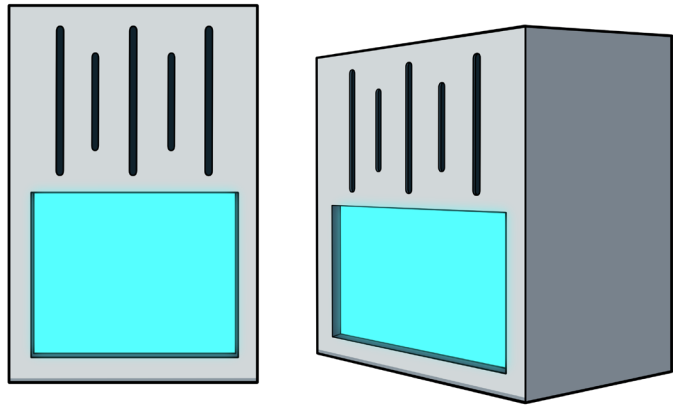

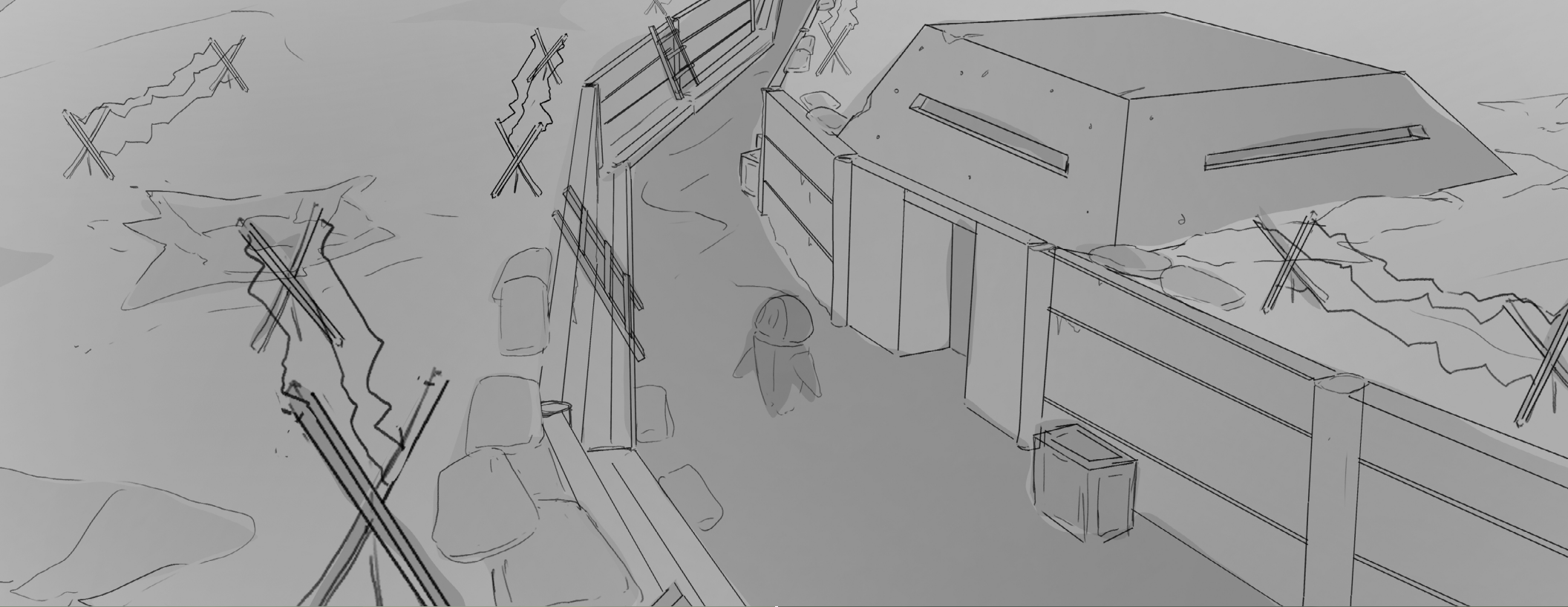

LEVEL MAP | SCENE | 7 | DREAM SEQUENCE 1° ENVIRONMENT

PLAY AREA

IF THE CHARACTER STREAMS TOO FAR FROM THE PLAY AREA, YOUR CHARACTER WILL BE SHOT, RESETTING TO A CHECKPOINT.

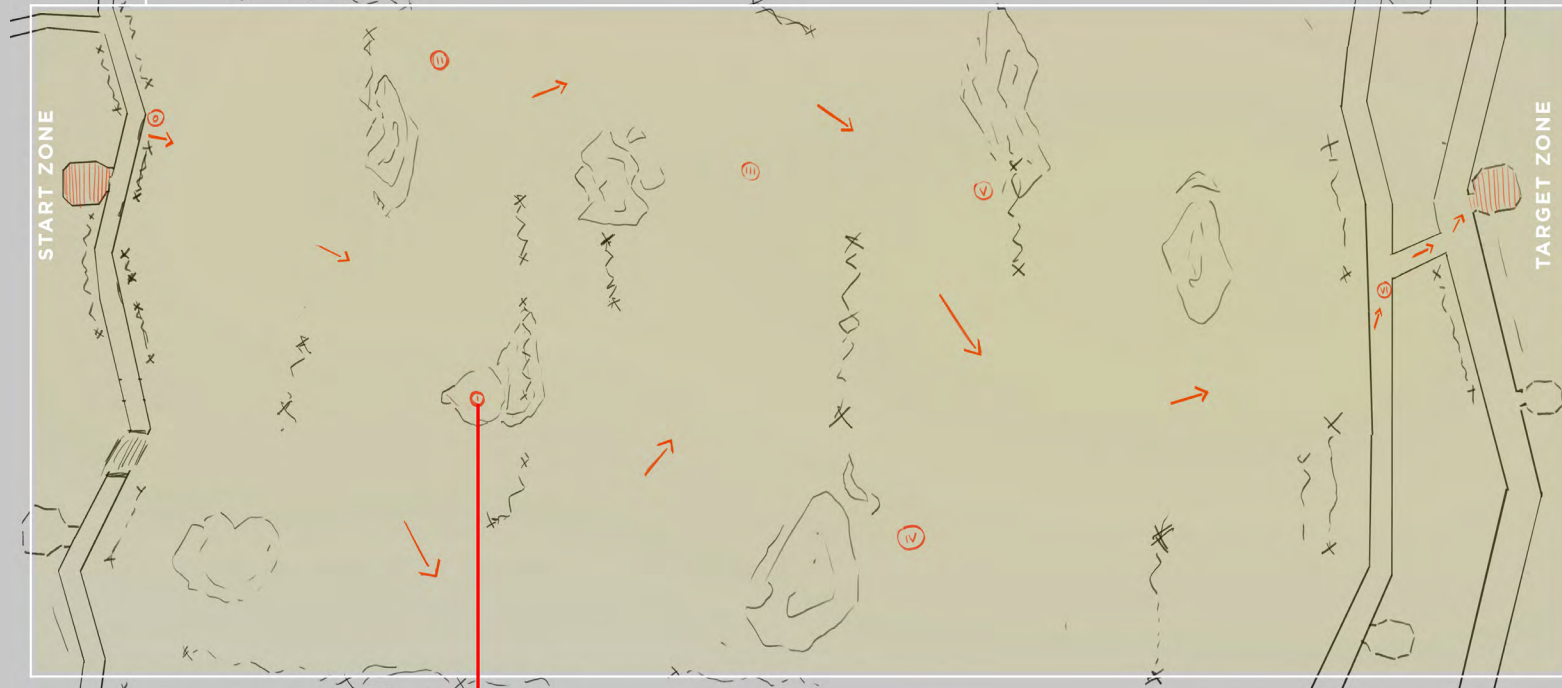

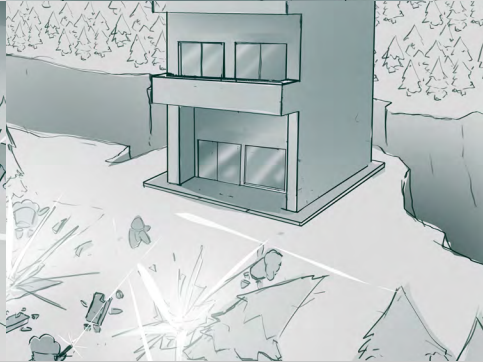
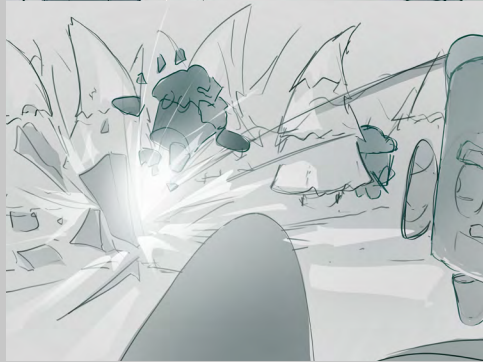
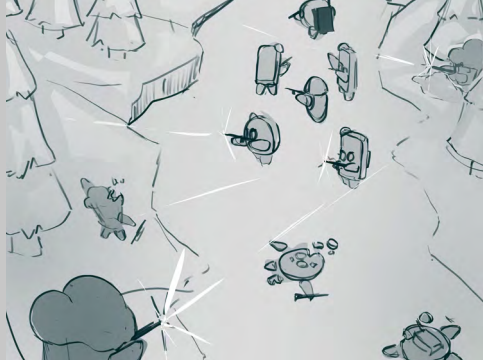
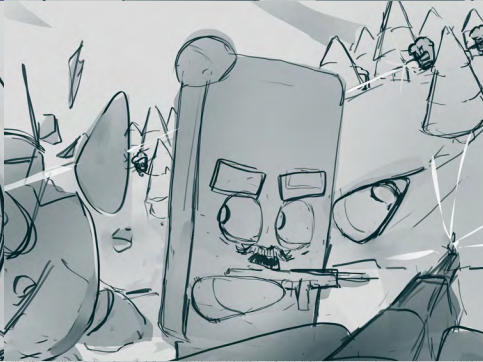
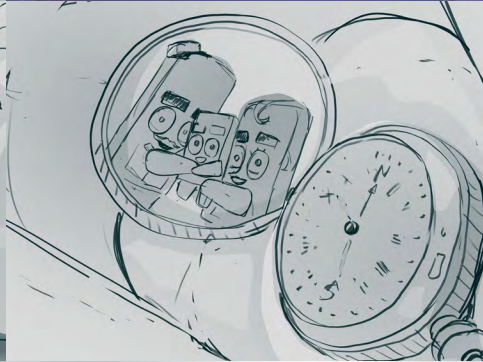

LEVEL MAP | SCENE | 7 | DREAM SEQUENCE

2° ENVIRONMENT

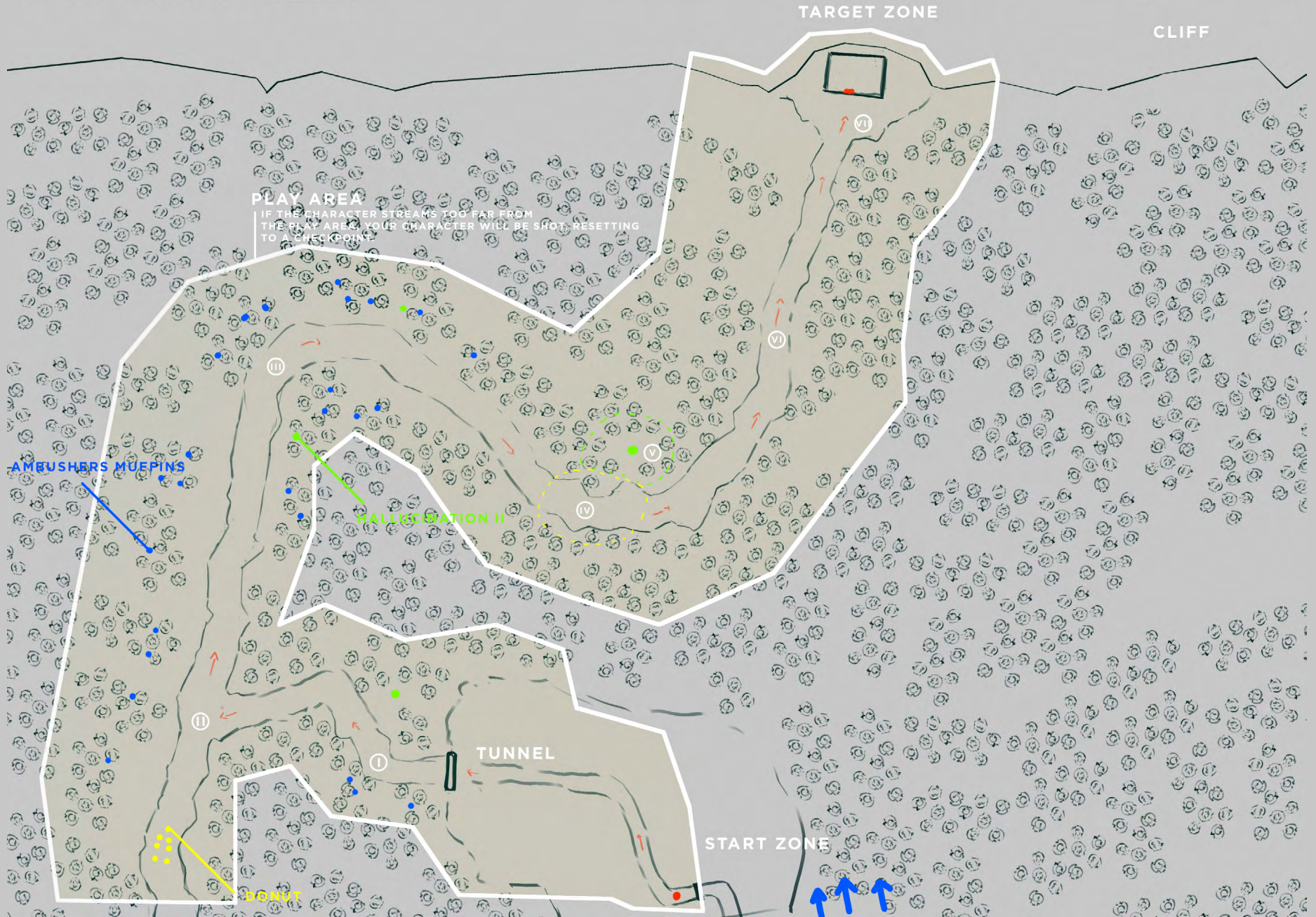



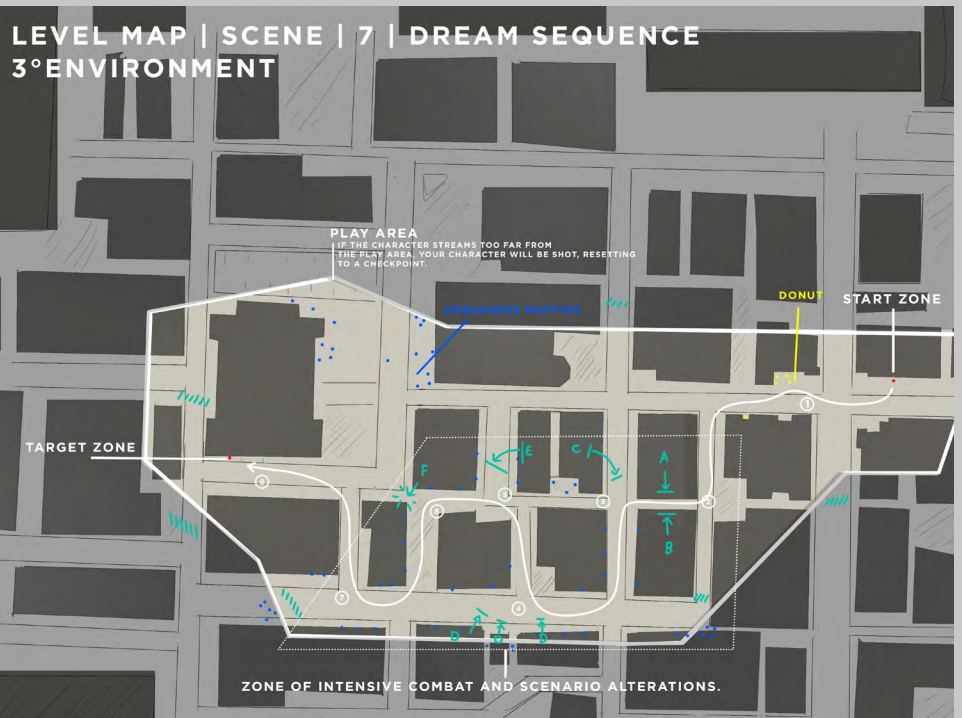
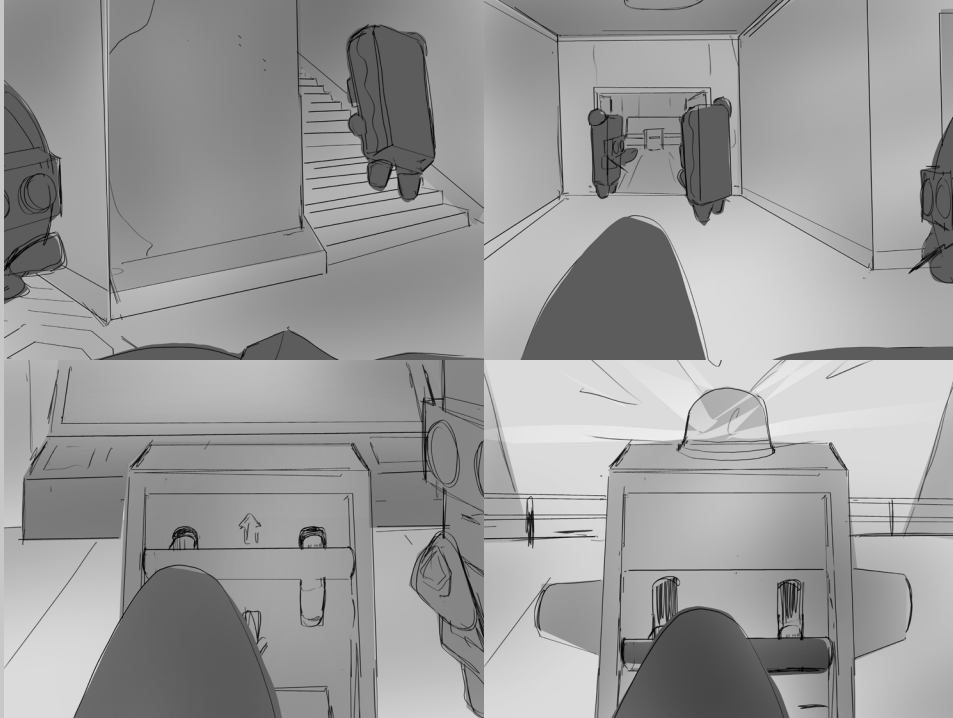
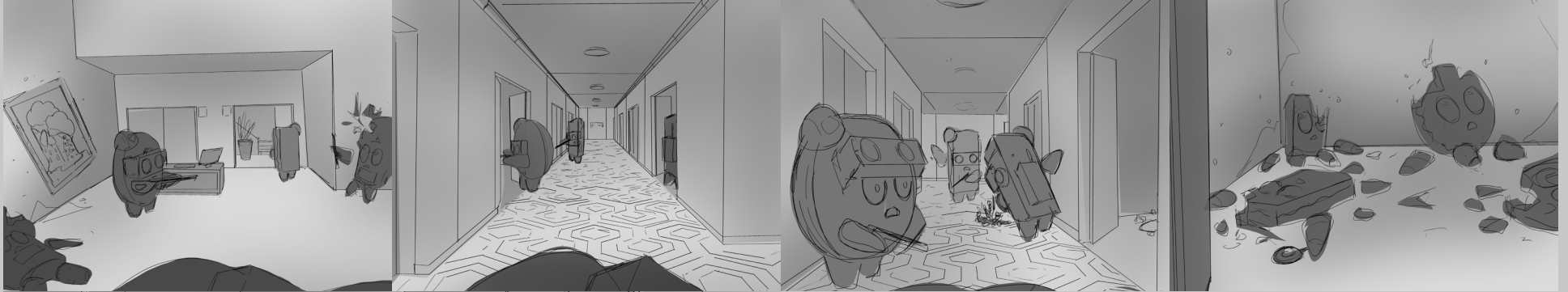
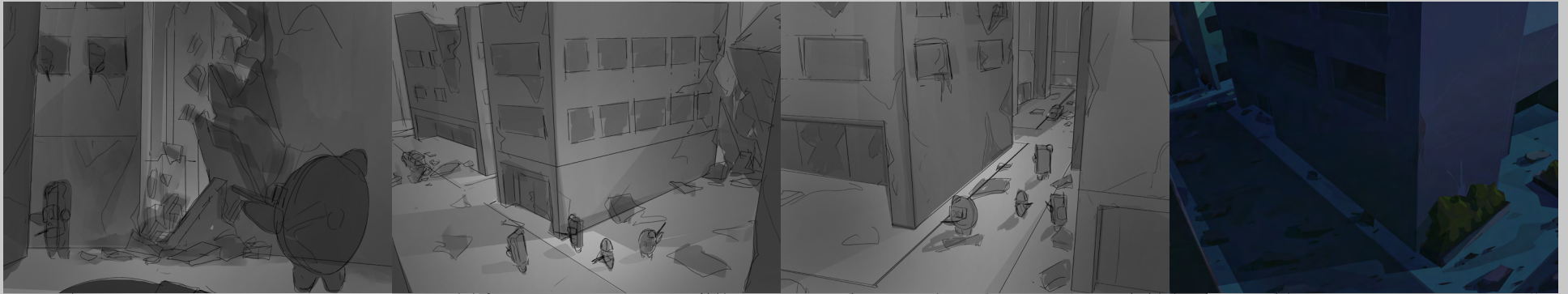

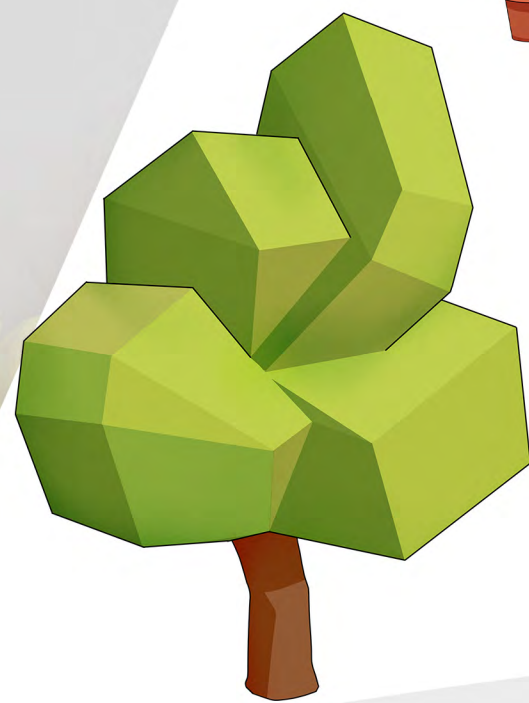
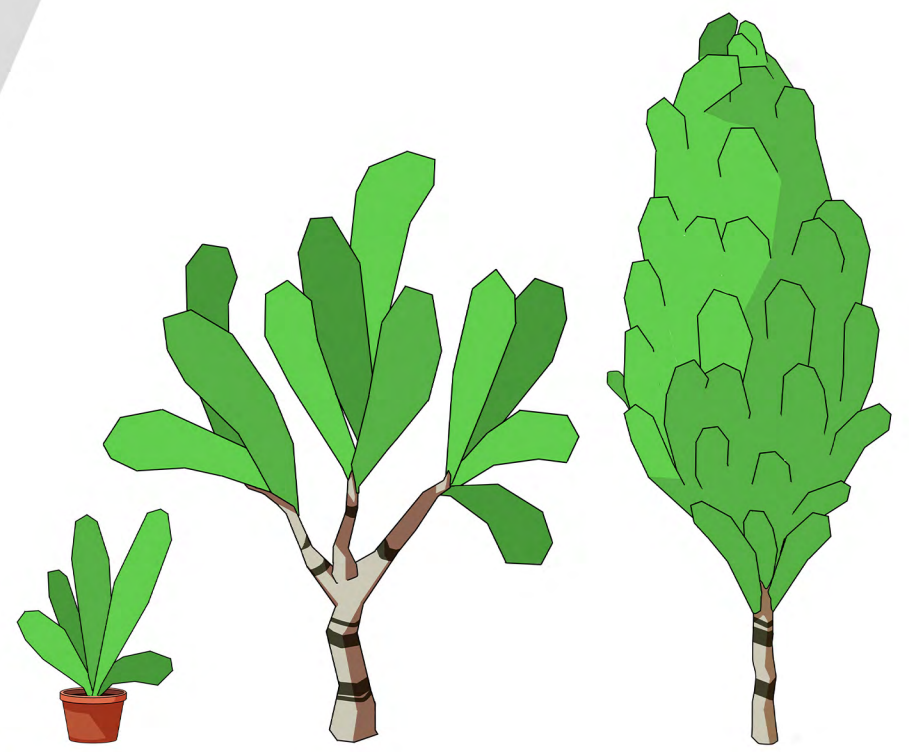







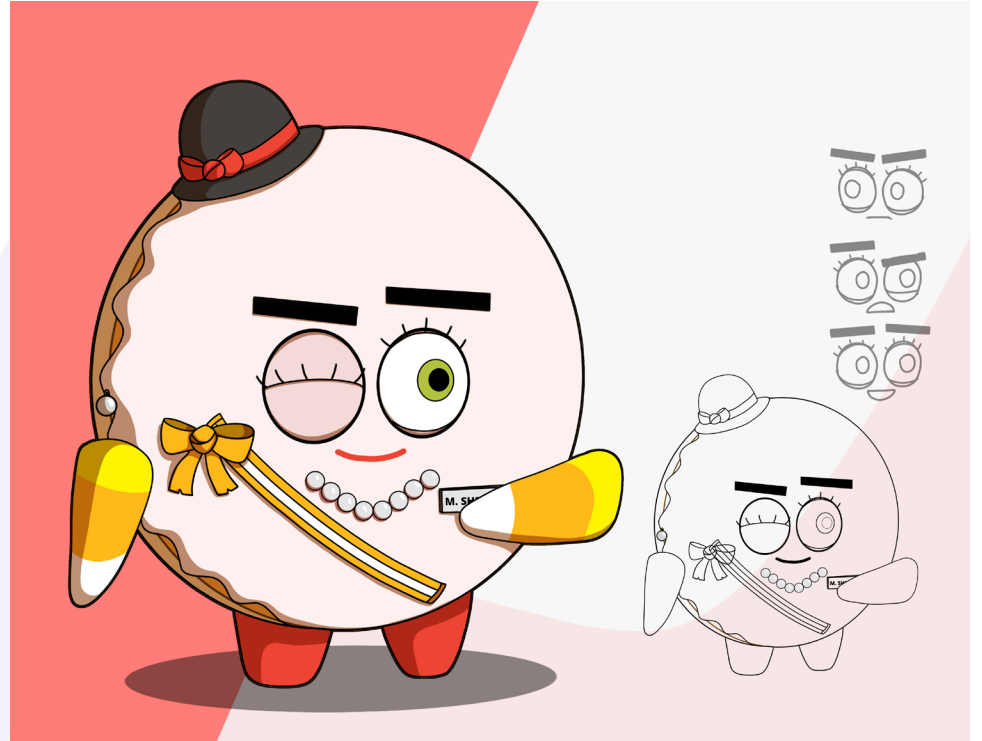
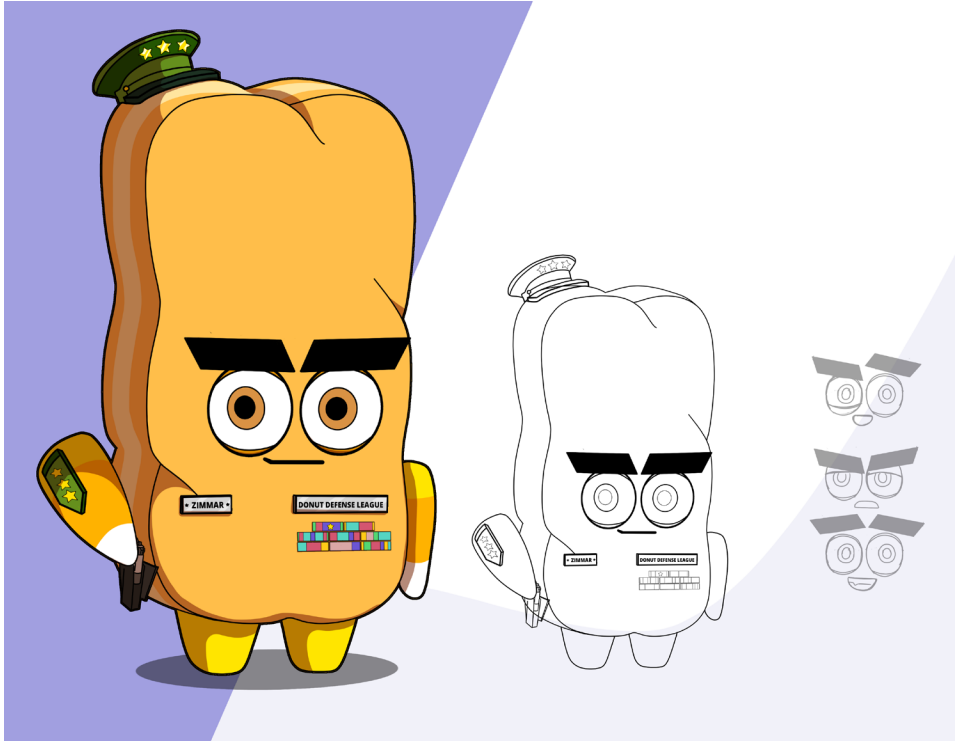
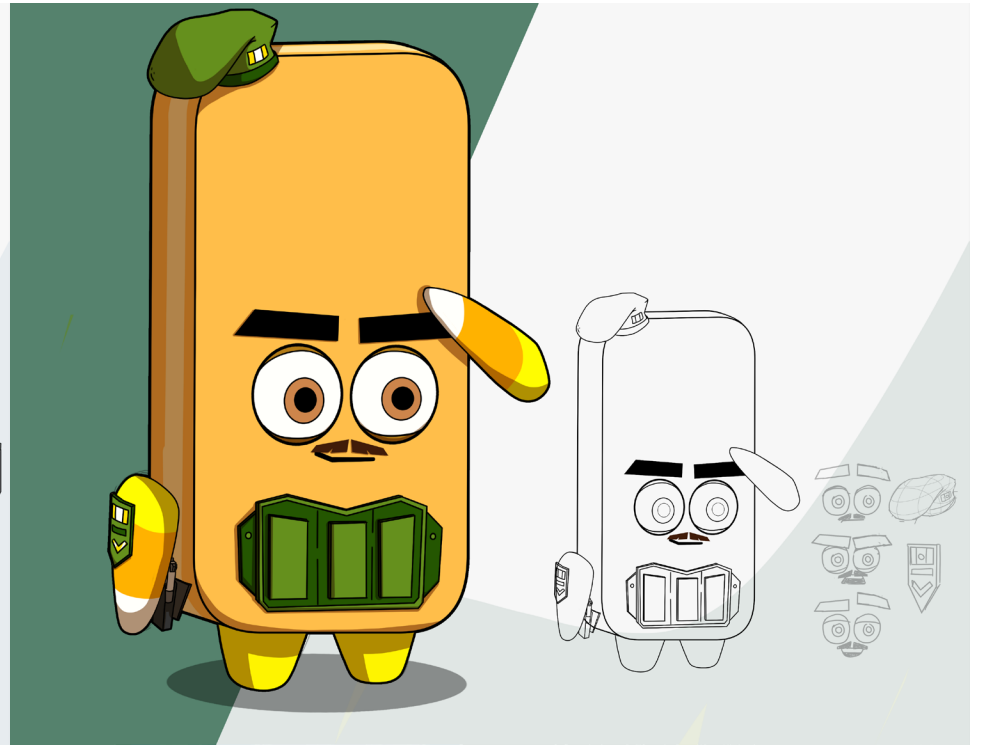
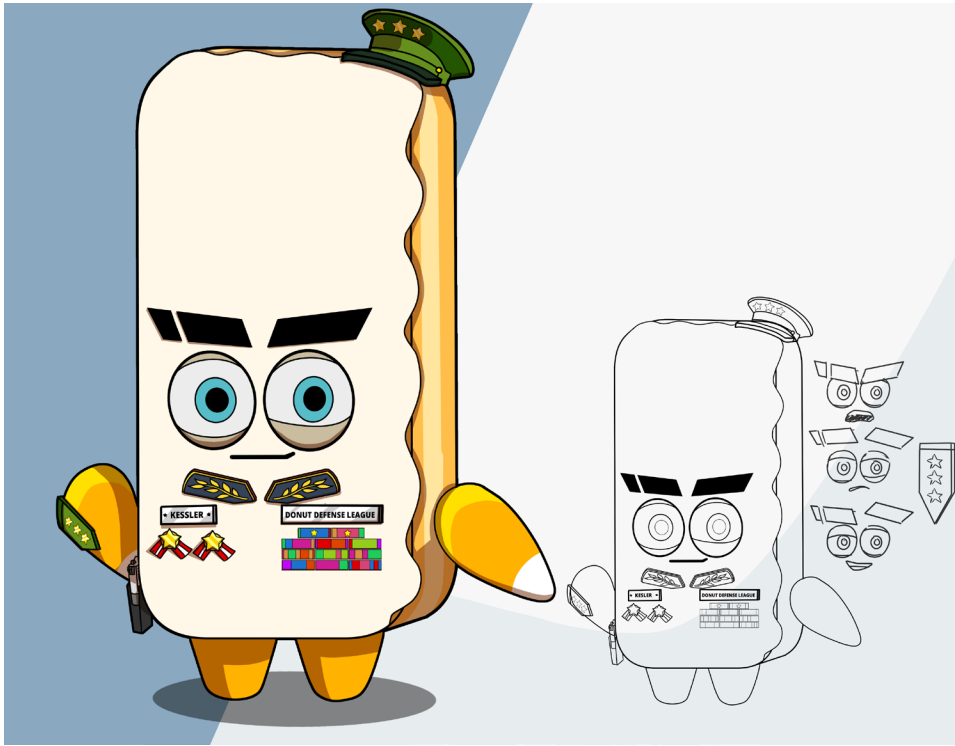

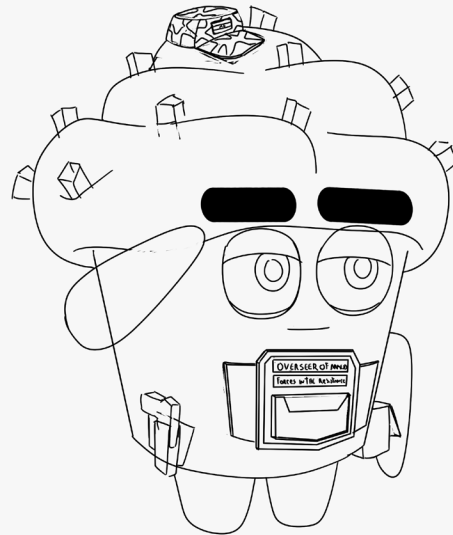
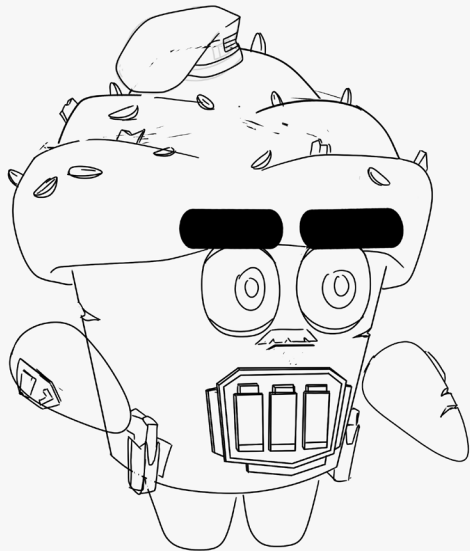

SOLDIER
DONUT
DEFENCE
LEGION



COMBAT RADIO OPERATOR
DONUT
DEFENCE
LEGION



SERGEANT | GENERAL
DONUT
DEFENCE
LEGION

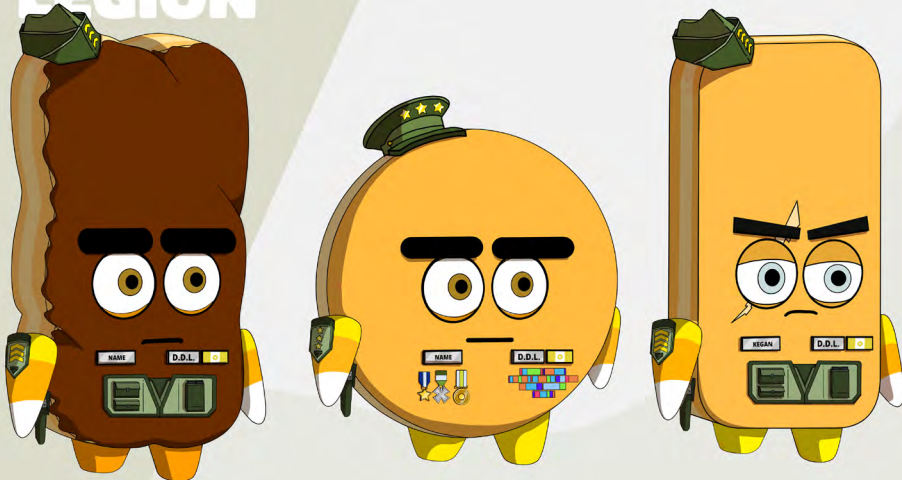

COMBAT MEDIC
DONUT
DEFENCE
LEGION



SPEC OPS SOLDIER
NEW
DONUT
ORDER



JUGGERNAUT
NEW
DONUT
ORDER

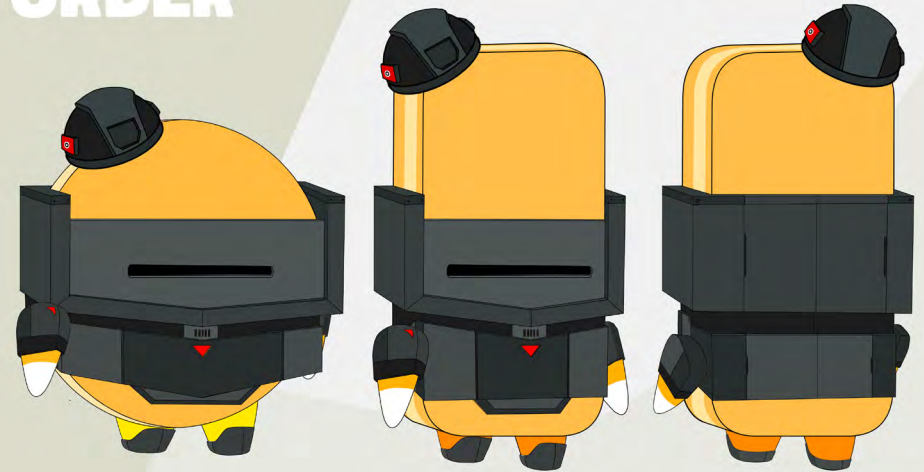
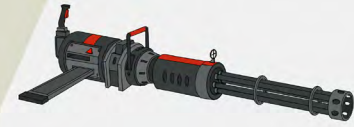

COMBAT MEDIC / RADIO
NEW
DONUT
ORDER

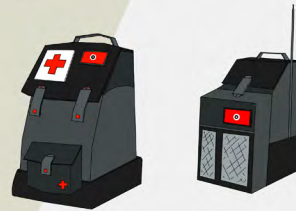

SERGEANT | GENERAL
NEW
DONUT
ORDER



DONUT / SCIENTIST
FACILITY X

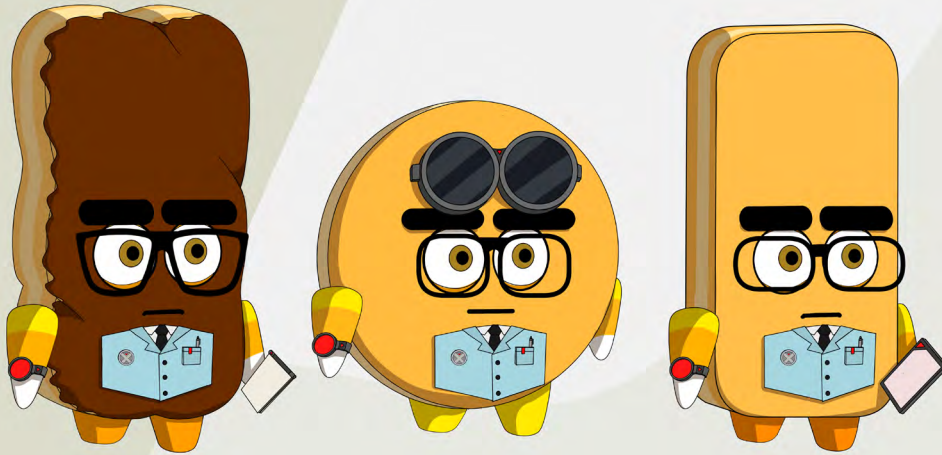

MUFFIN / SCIENTIST
SIM LABS



DONUT / GUARD
DREJNON PRISON

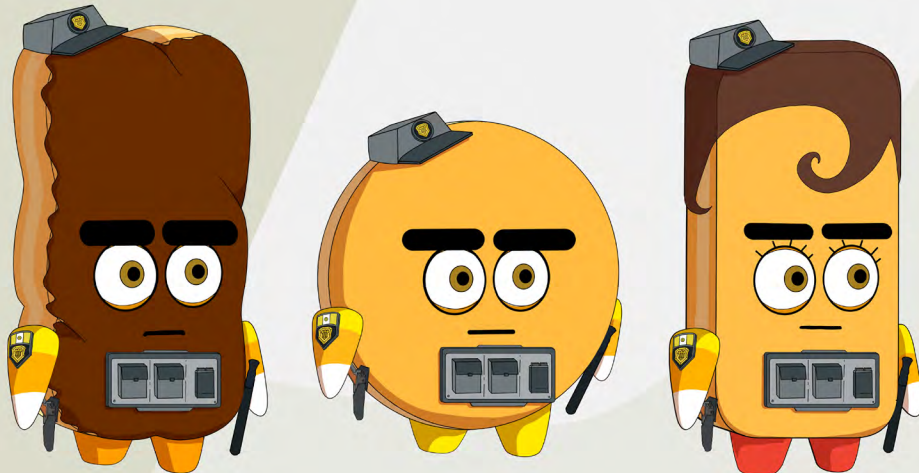

MUFFIN / SOLDIER
FROST PEAK



MUFFIN / SOLDIER
SACRED KNIGHTS



MUFFIN / MEDIC / RADIO
SACRED KNIGHTS



MUFFIN / MEDIC / RADIO
MUFFIN RESISTANCE



MUFFIN / SOLDIER
MUFFIN RESISTANCE



MUFFIN / B
WORKER



DONUT / A
POLICE



DONUT / A
POLITICIAN

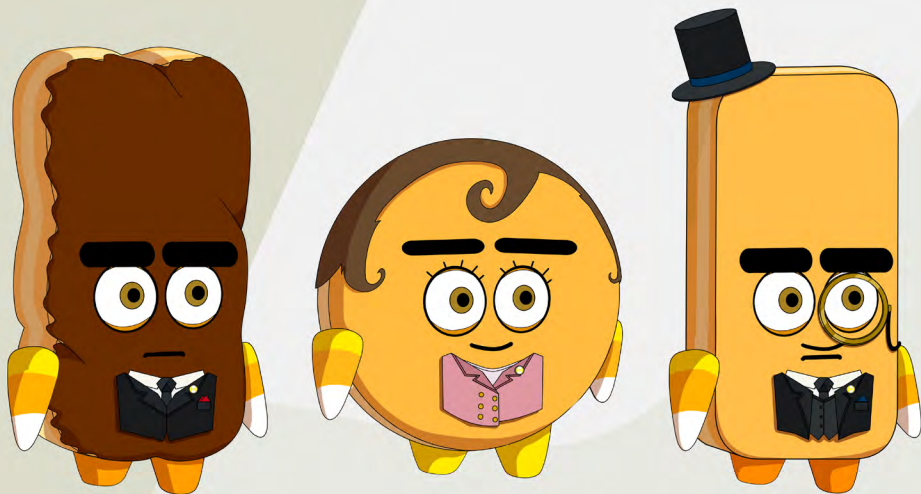

MUFFIN / A
POLITICIAN

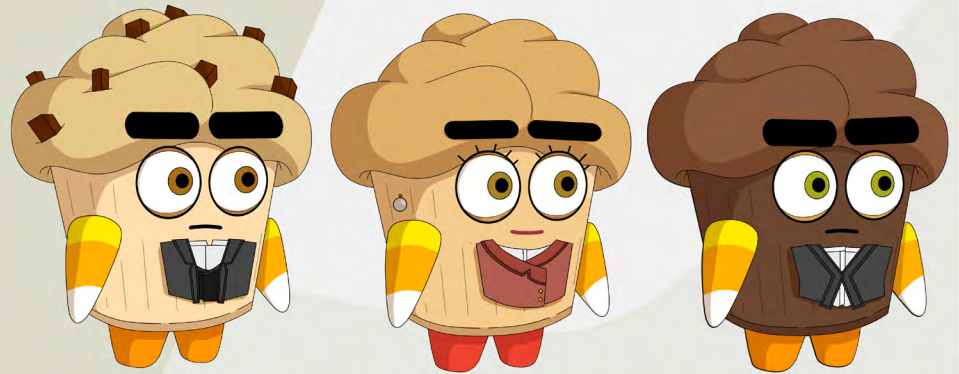

DONUT / A
CIVILIAN

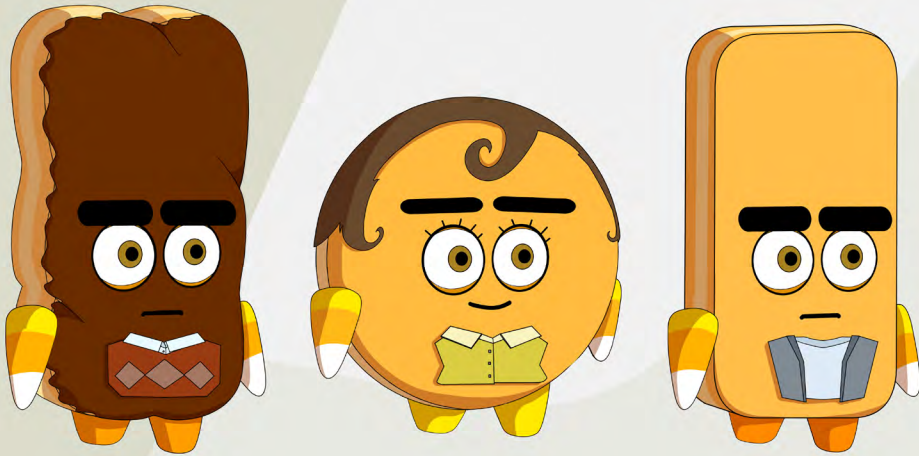

DONUT / A
CIVILIAN

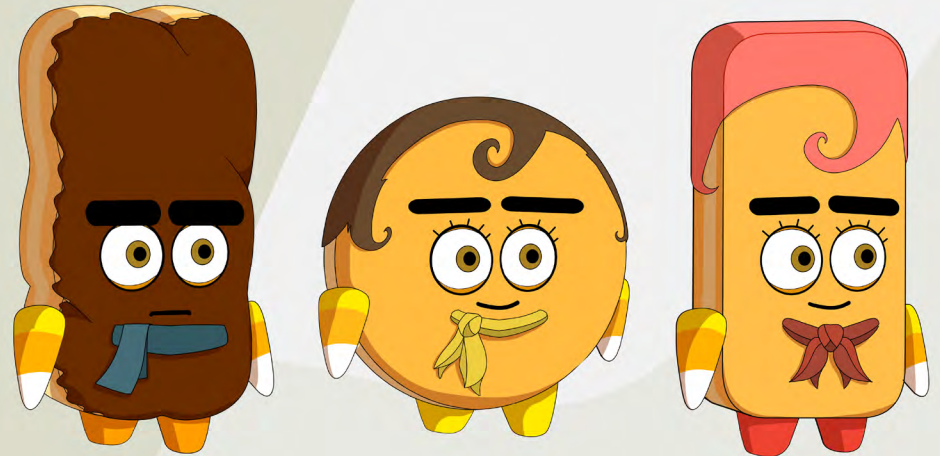

MUFFIN / A
CIVILIAN

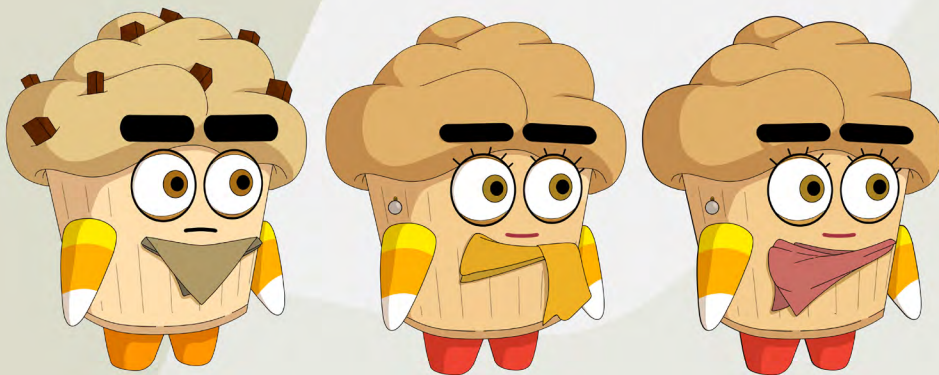

MUFFIN / A
CIVILIAN



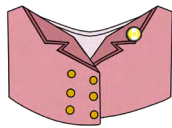
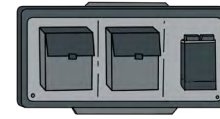
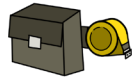
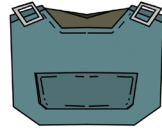
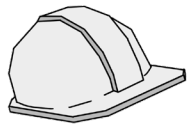



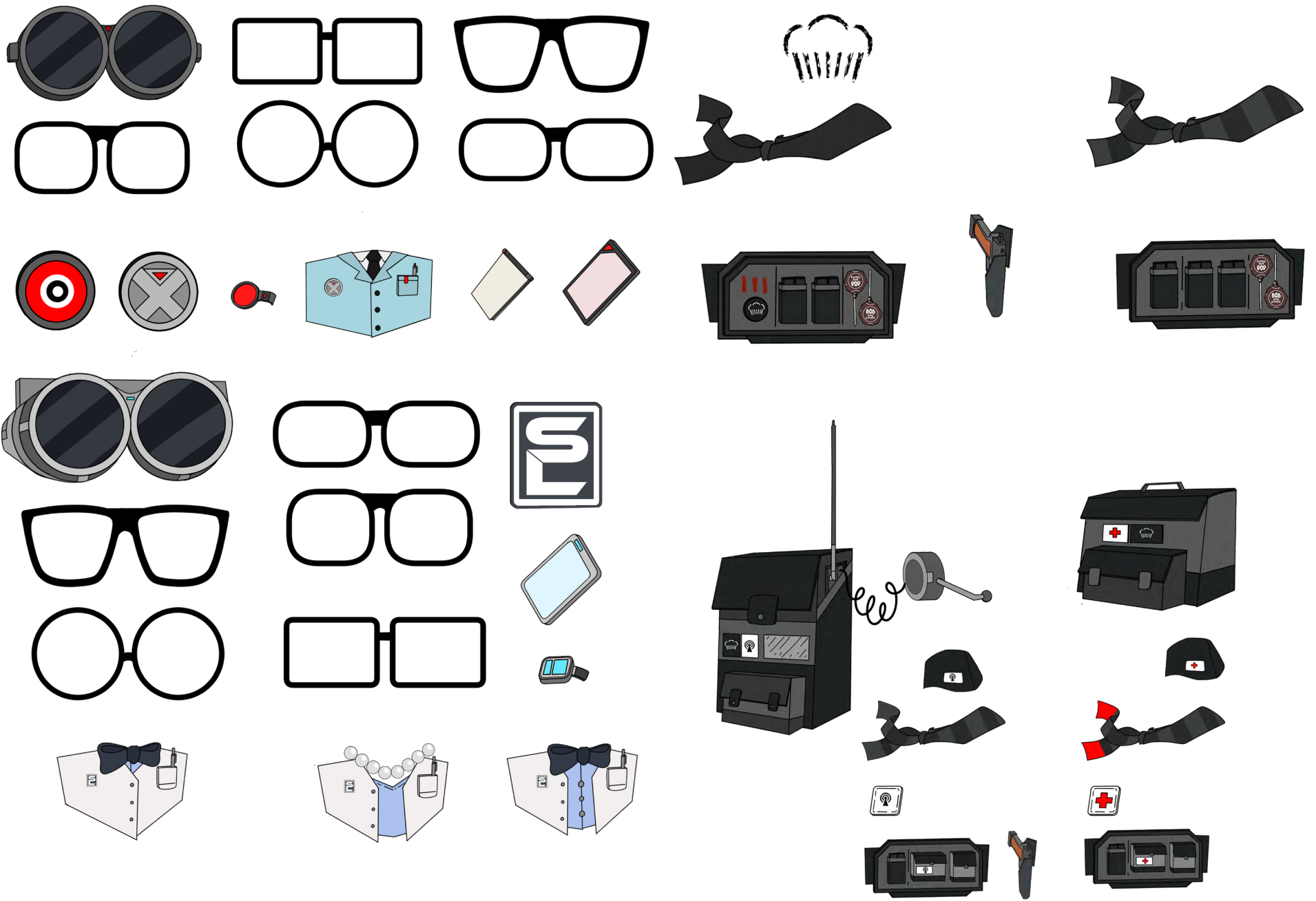





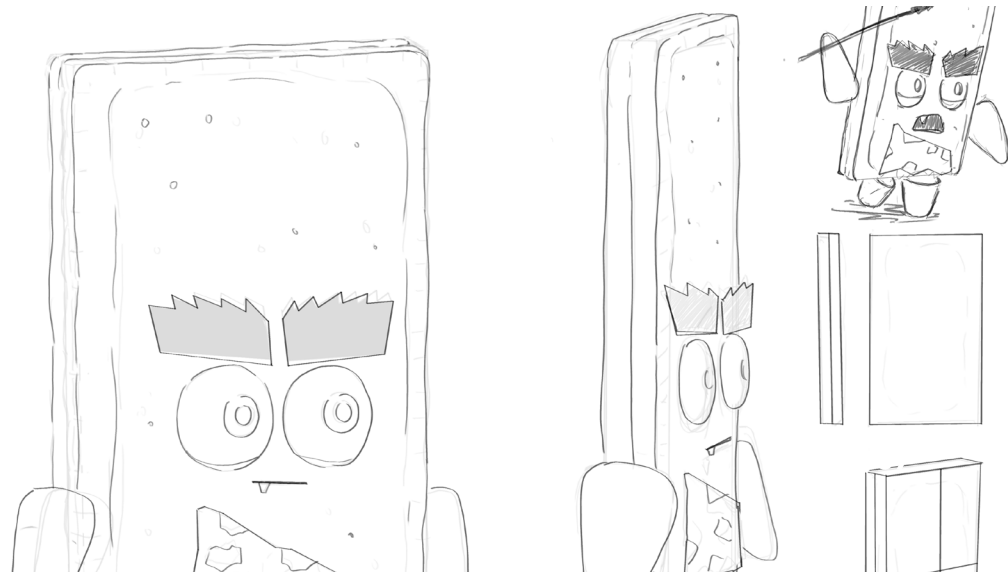
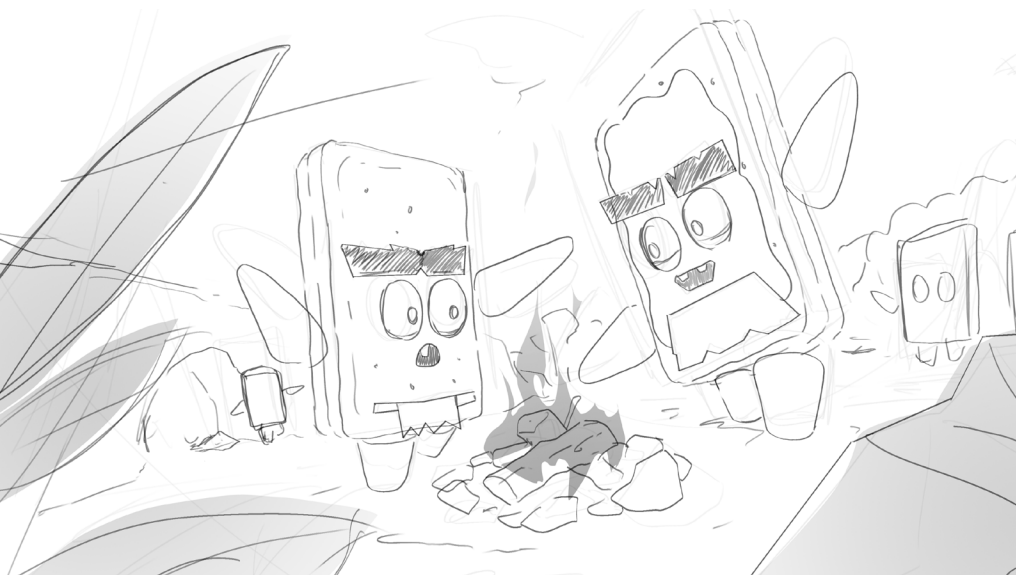
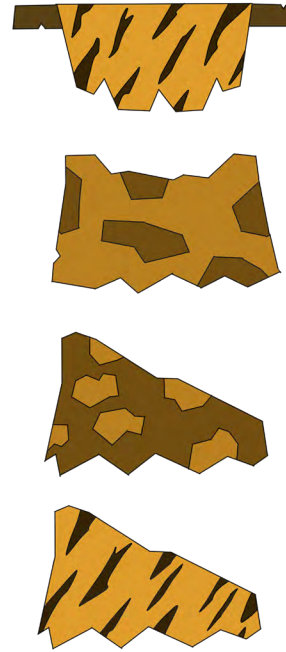
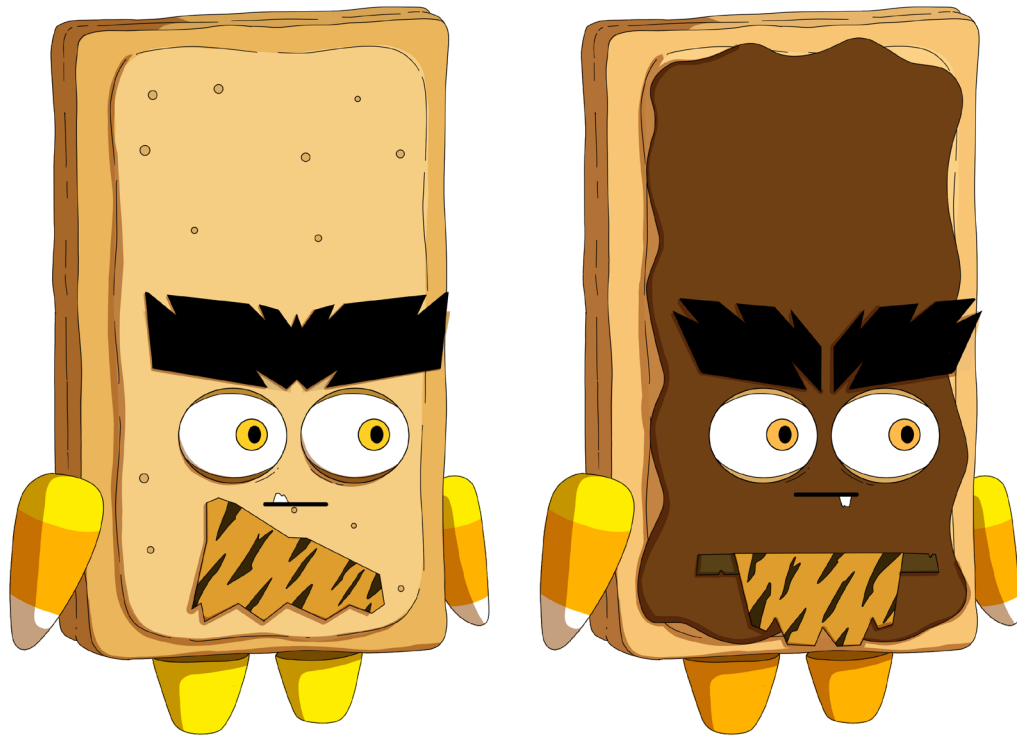

CONCEPTUAL STORYBOARDS AND ANIMATICS





ACT 1.

A1-S01



A1-S02

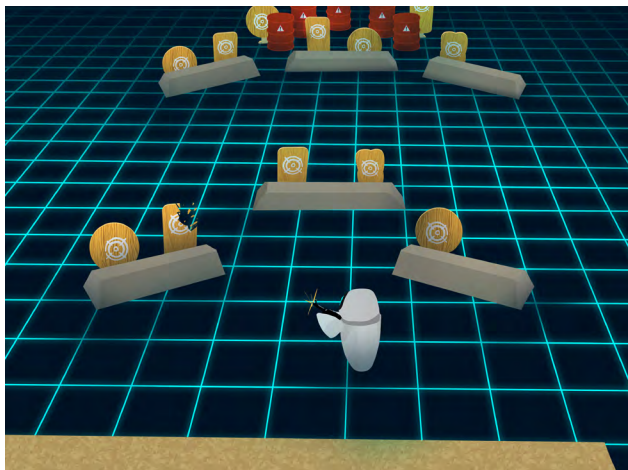

A1-S03



A1-S04



A1-S05

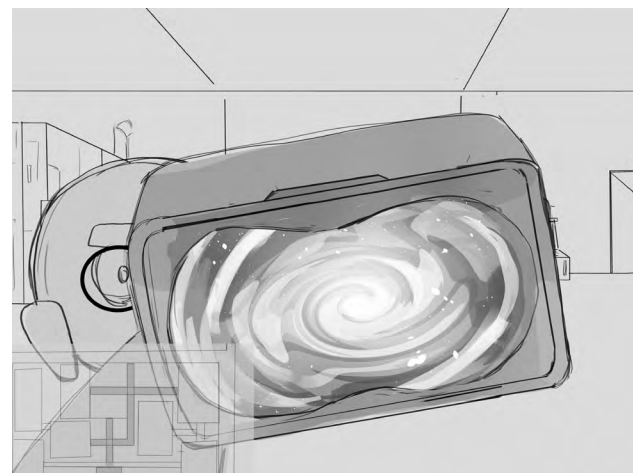
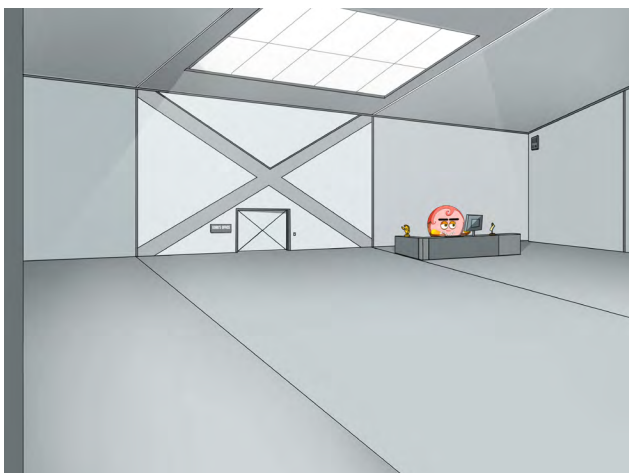
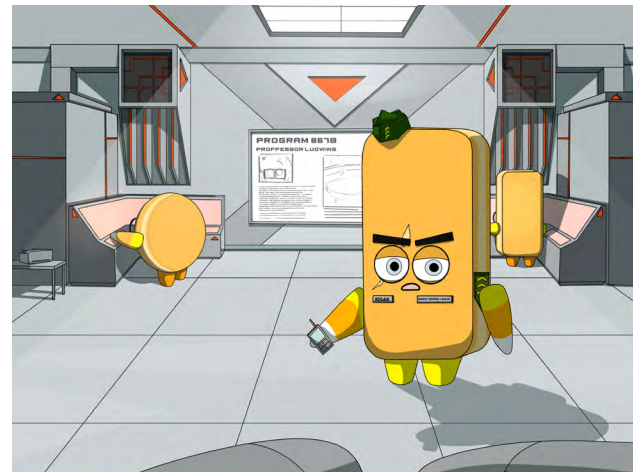

A1-S06

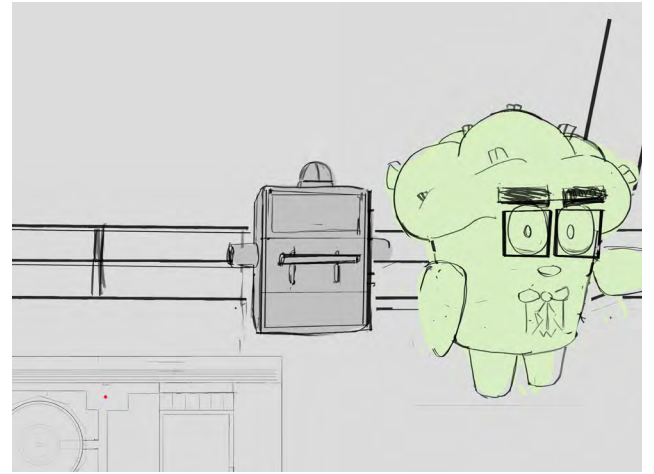
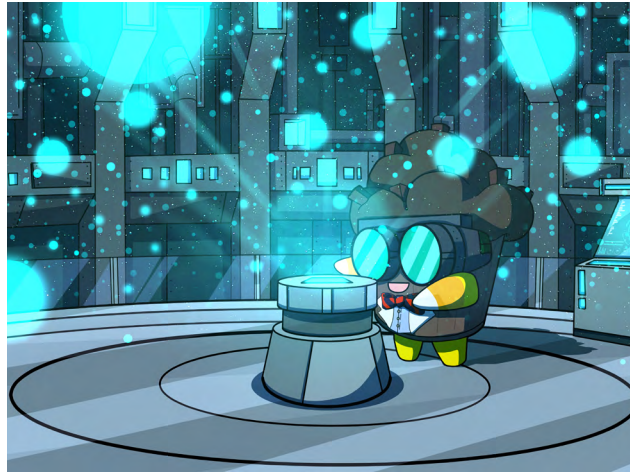
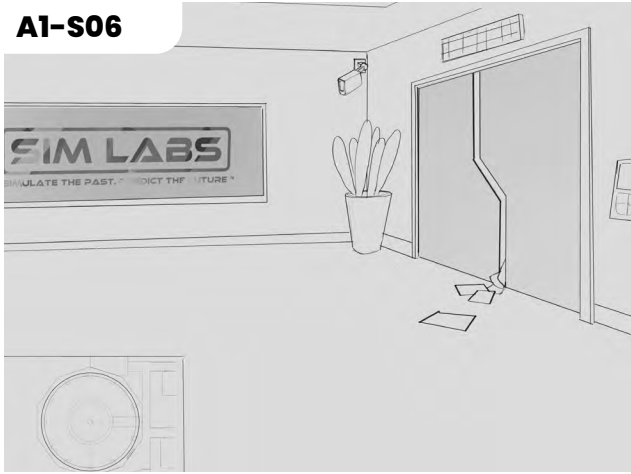

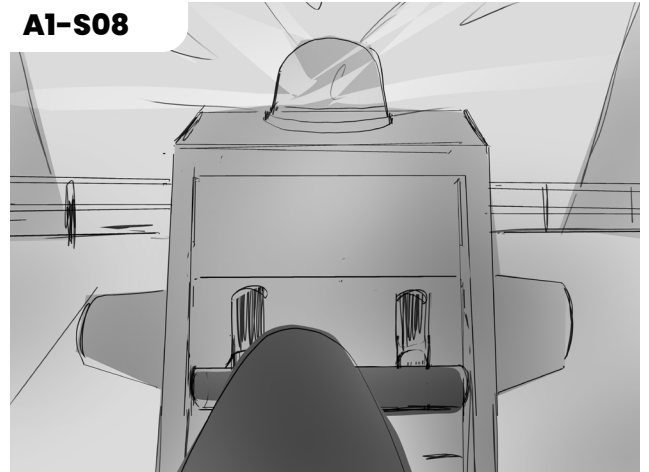
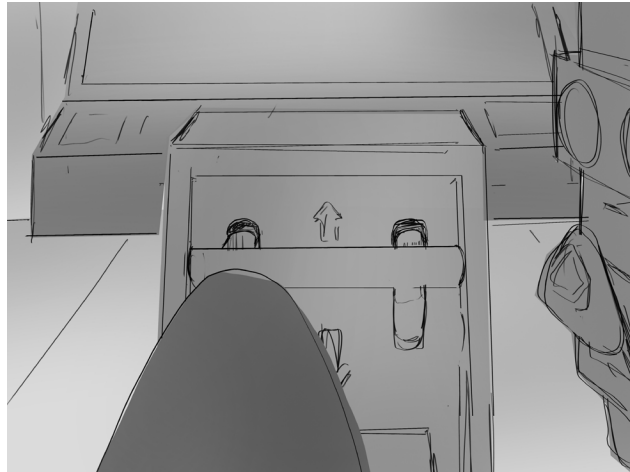

A1-S08

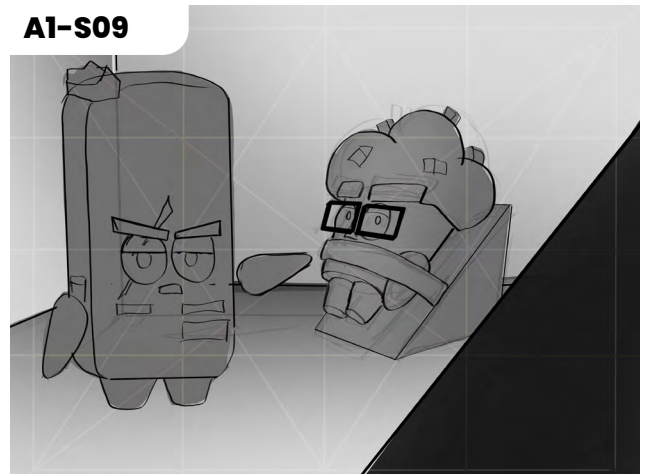

A1-S09



ACT 2.

A2-S01

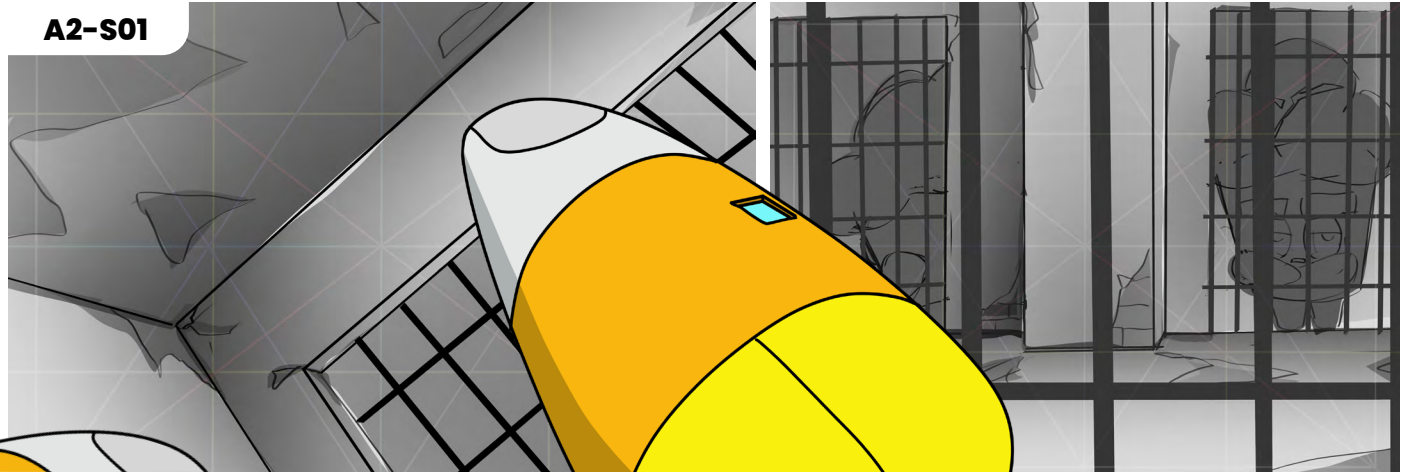

A2-S02

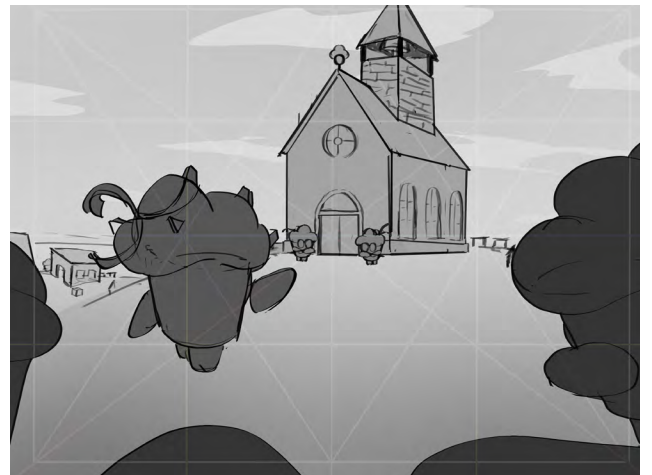

A2-S03

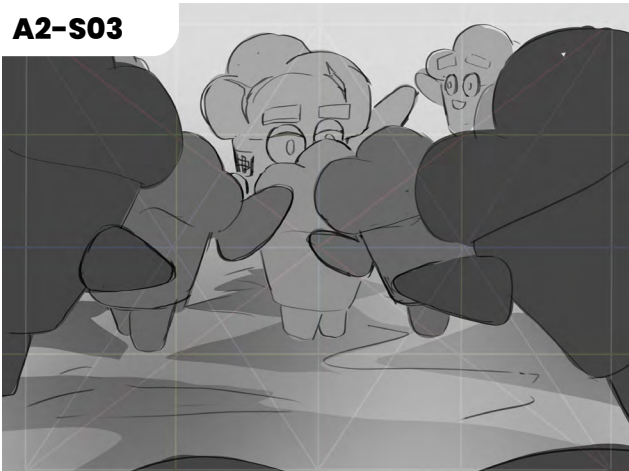

A2-S04

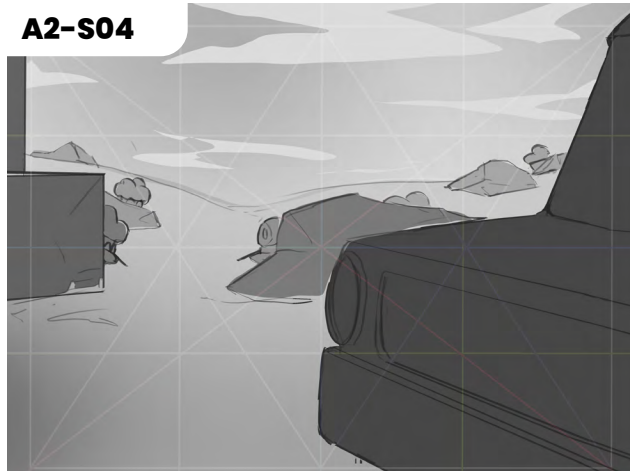

A2-S06

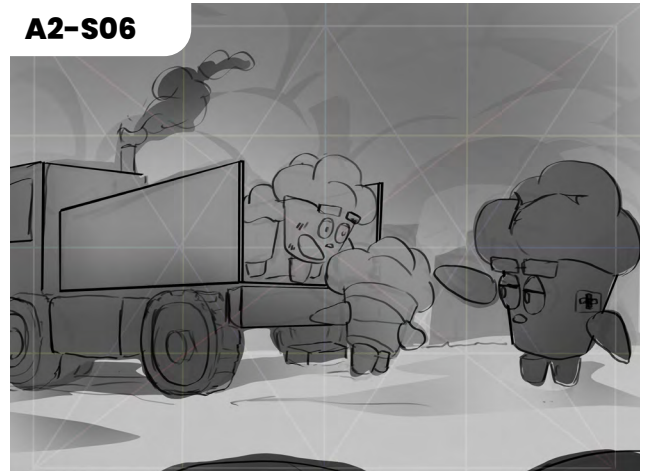

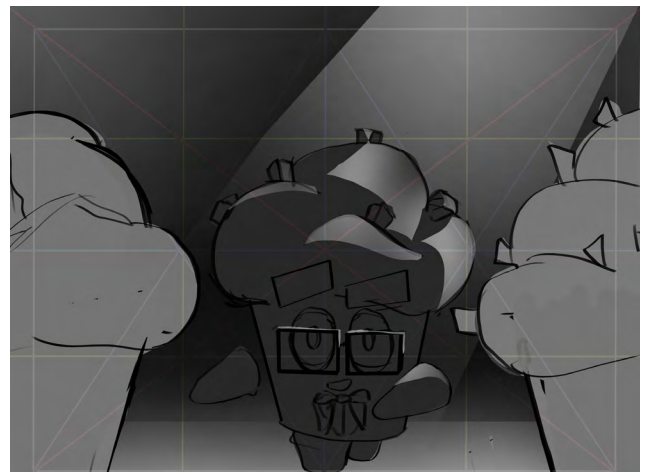
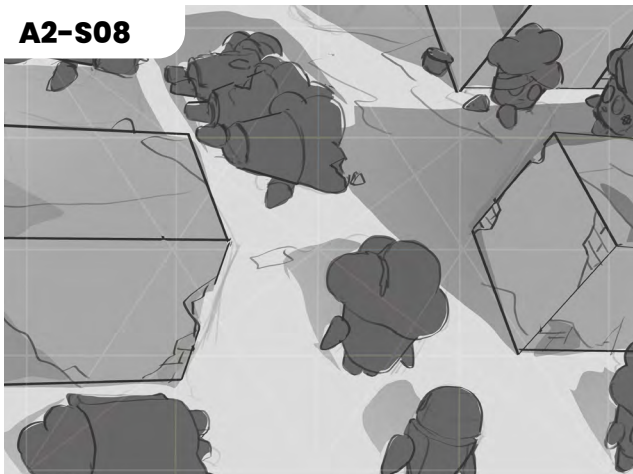

A2-S07

A2-S08

A2-S09

A2-S10

A2-S11

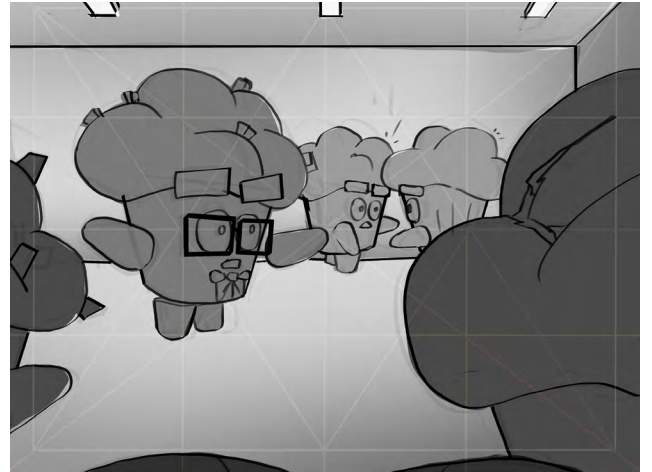
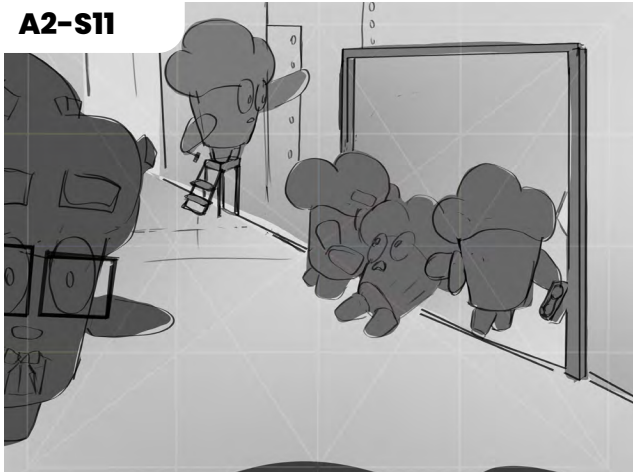

A2-S12



A2-S13



A2-S14

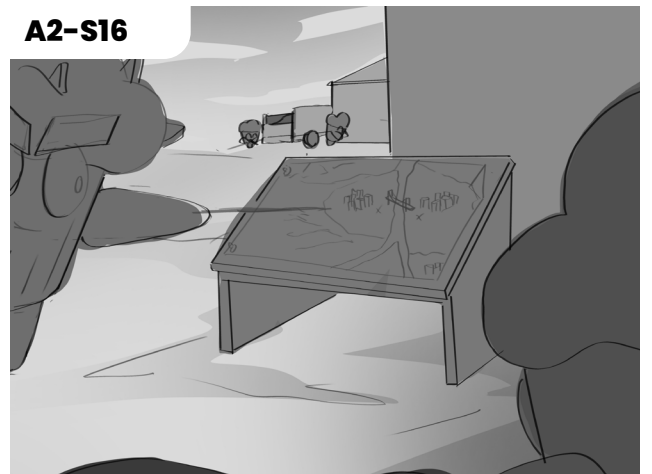
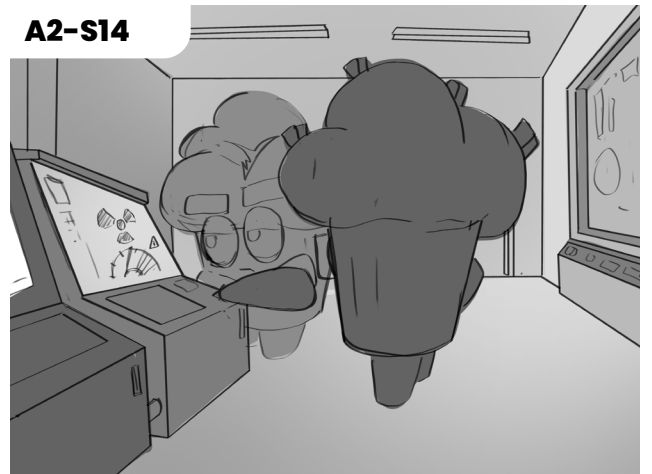

A2-S16

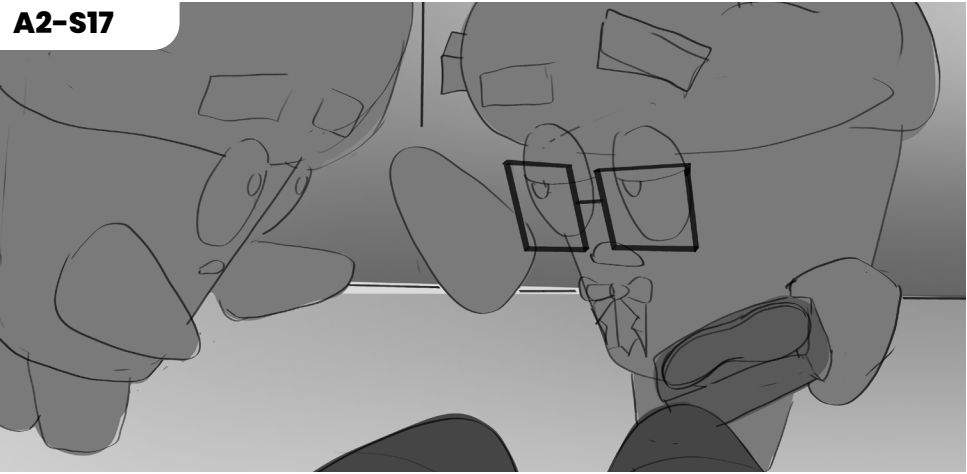

A2-S17

ACT 3.

A3-S01

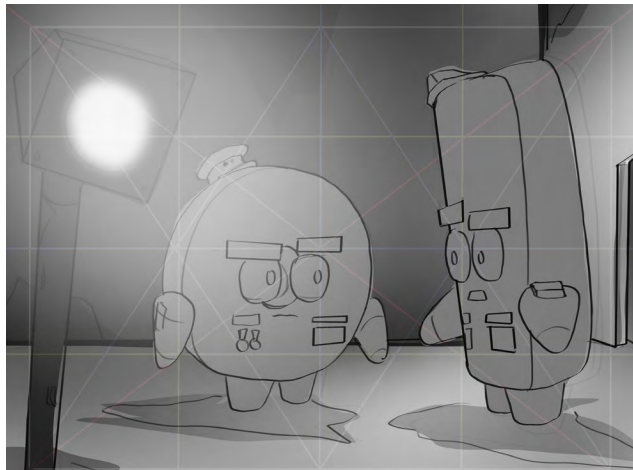
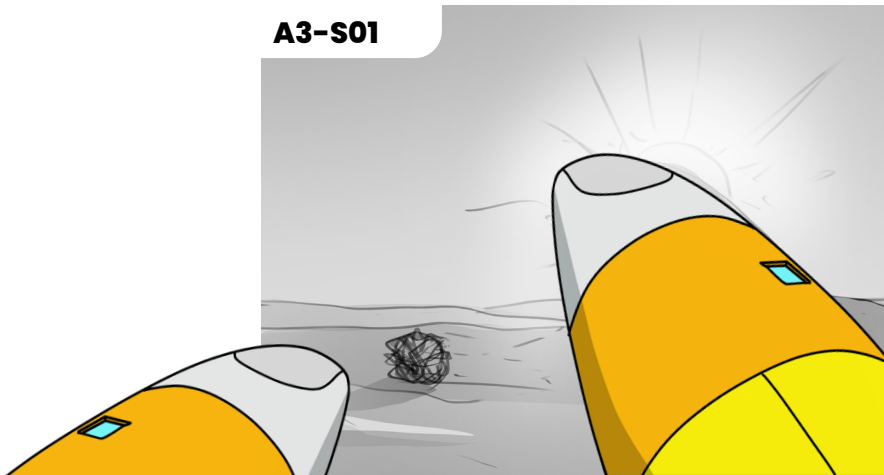

A3-S02

A3-S03



A3-S04



A3-S05

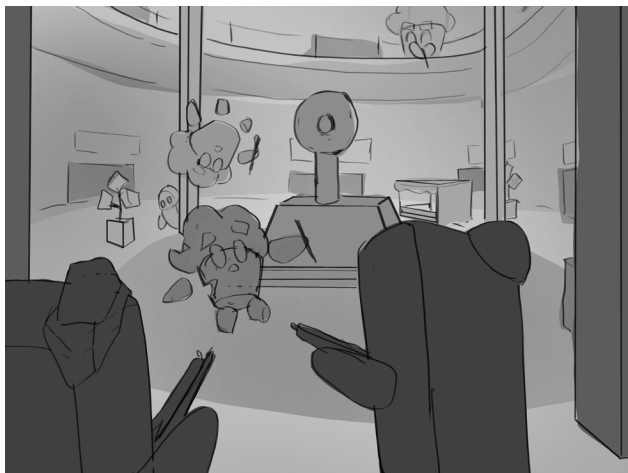

A3-S06





A3-S07



A3-S08

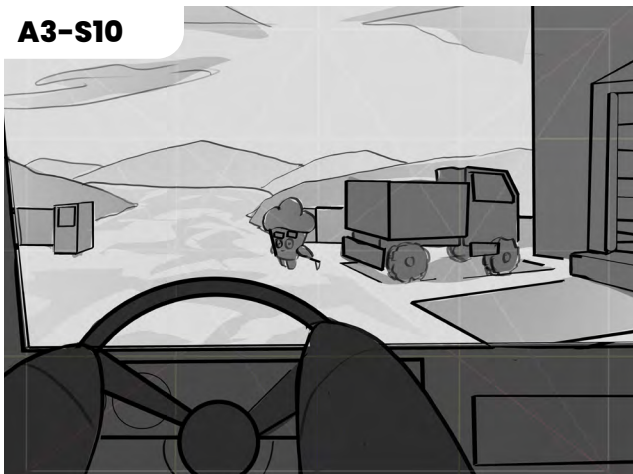
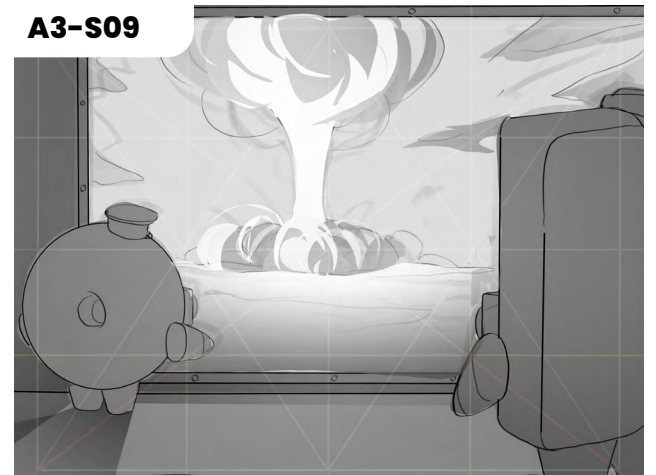

A3-S10

ACT 4. "Good Path"

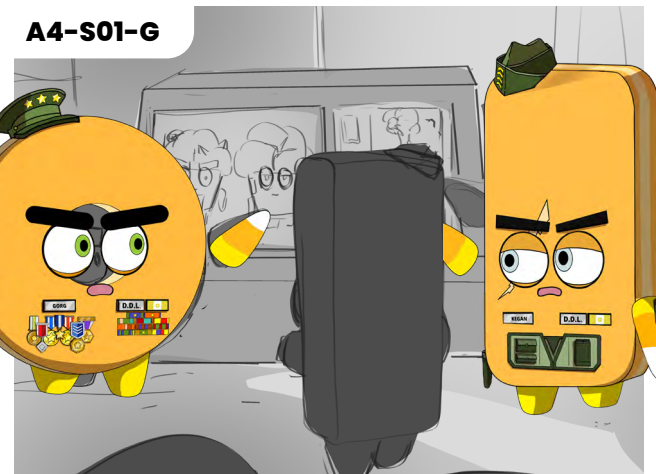

A4-S01-G

A4-S02-G



A4-S03-G

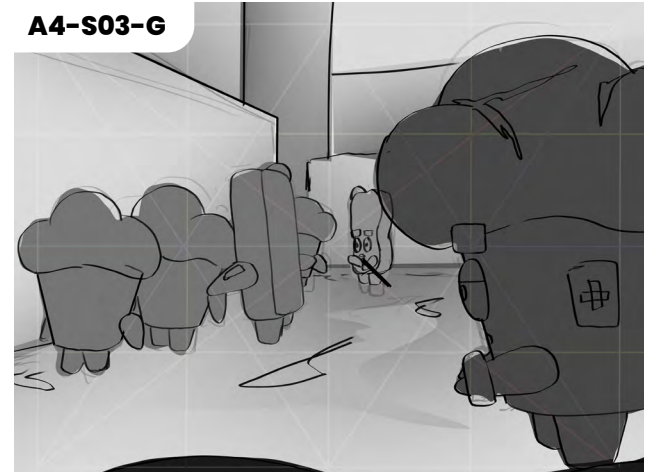

A4-S04-G



A4-S05-G



A4-S06-G

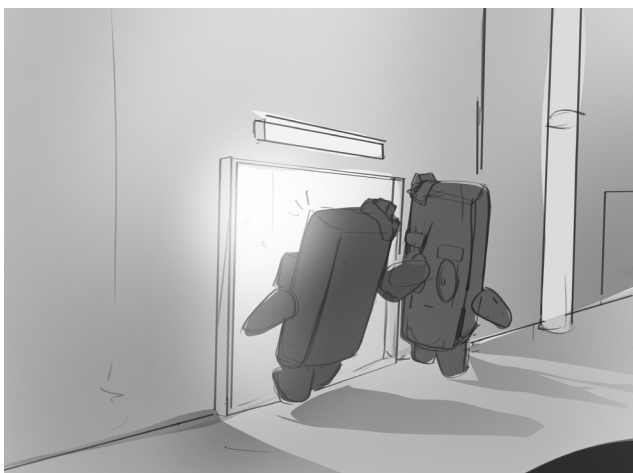
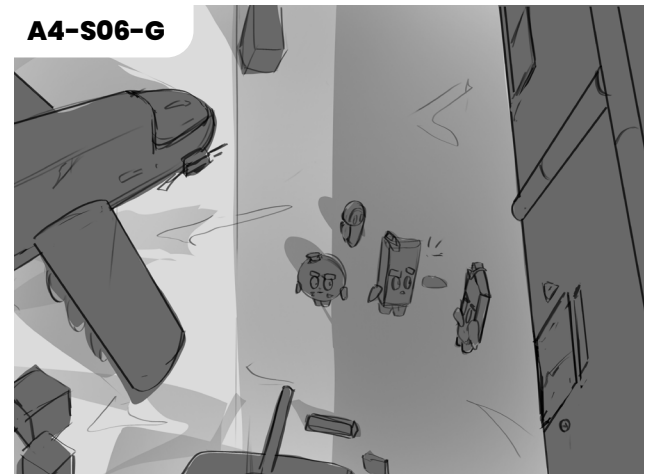

A4-S07-G



A4-S08-G



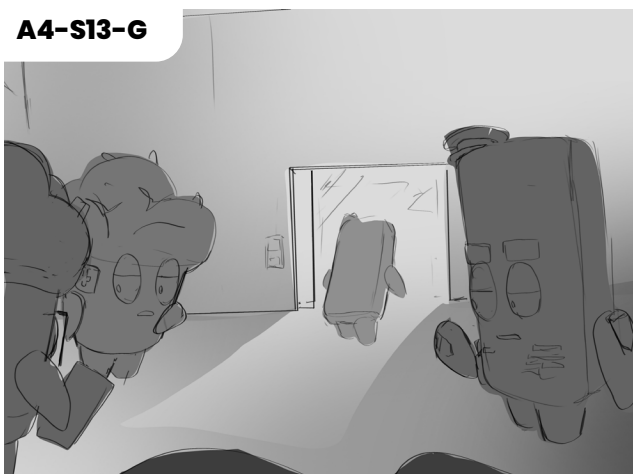
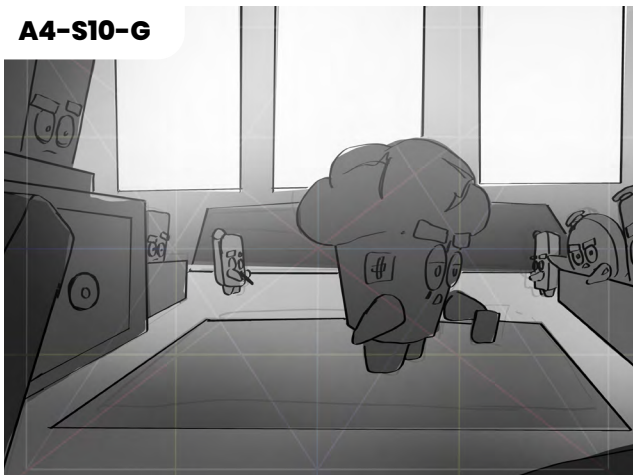
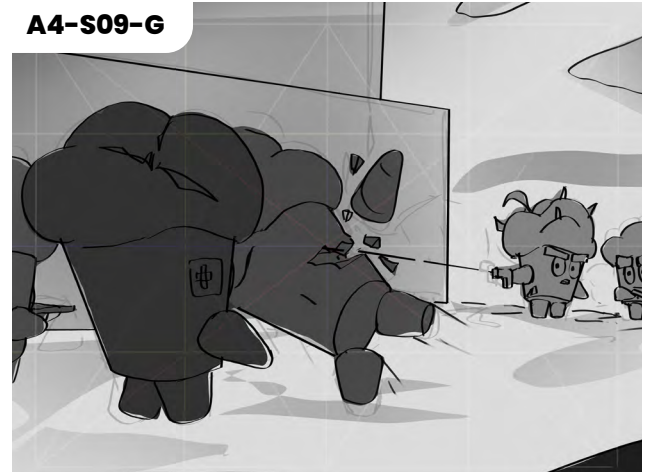
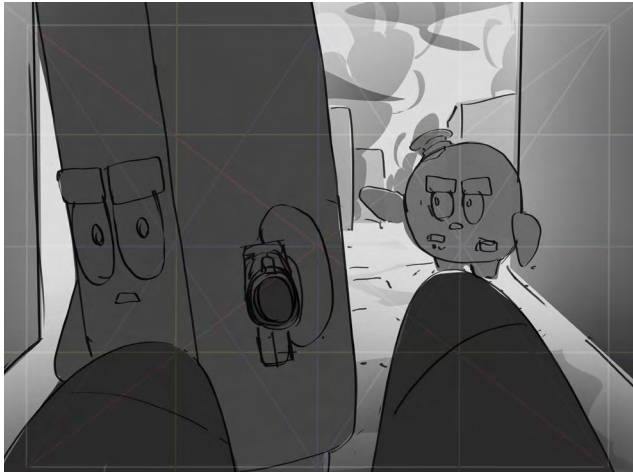



A4-S15-G

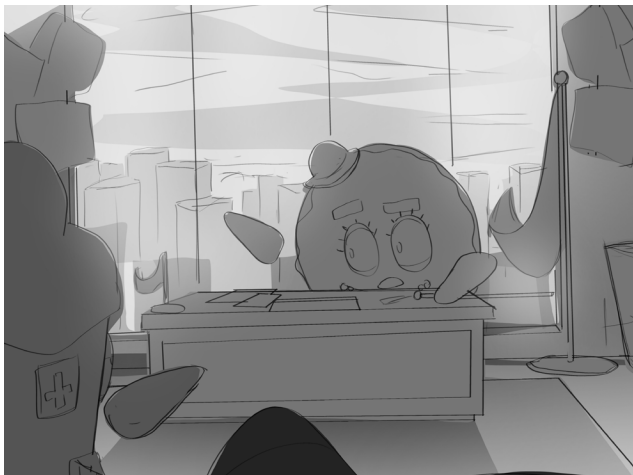
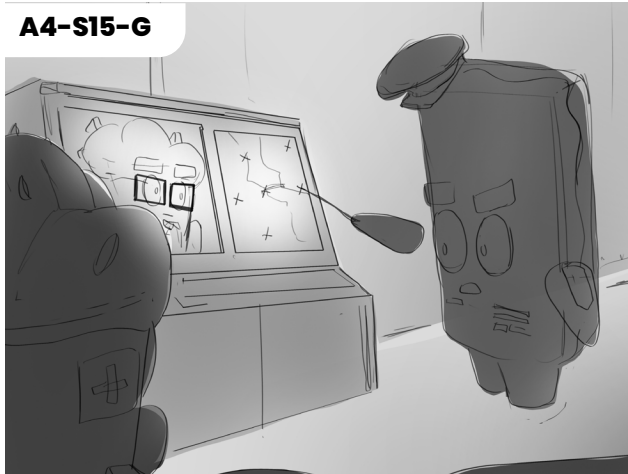

A4-S16-G

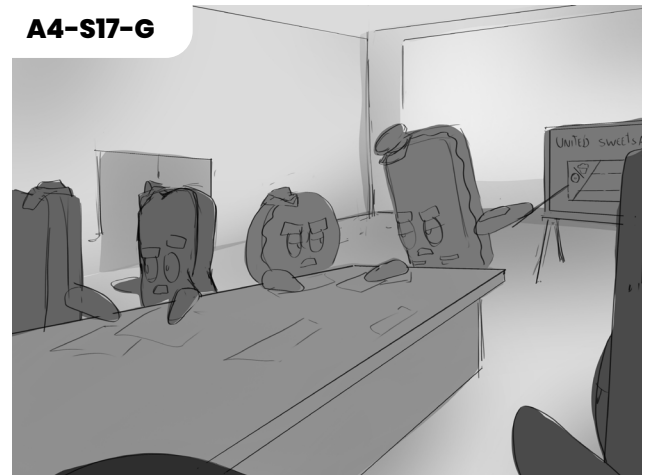

A4-S17-G



A4-S18-G

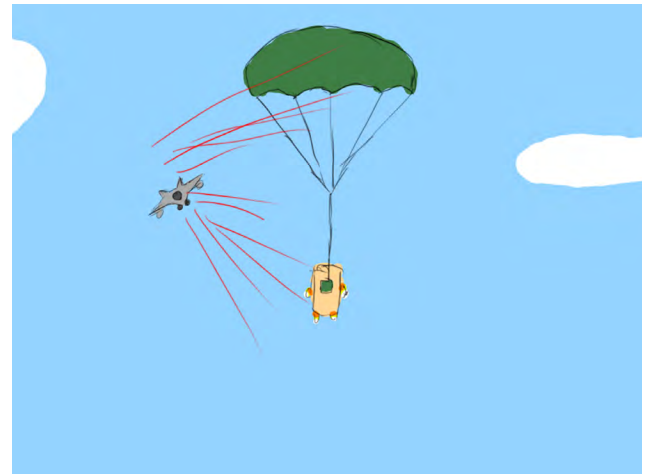

A4-S19-G

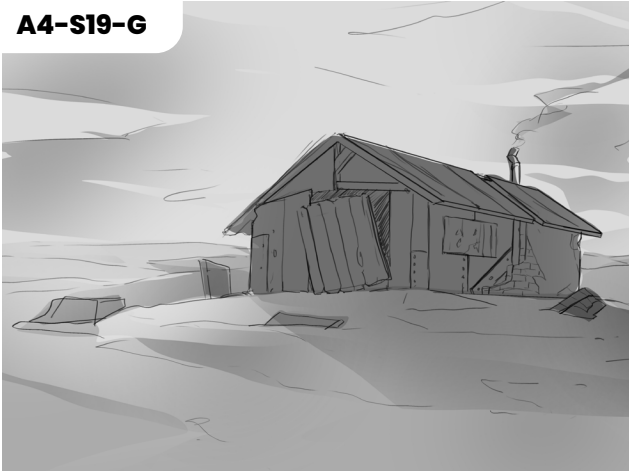

A4-S20-G



A4-S21-G

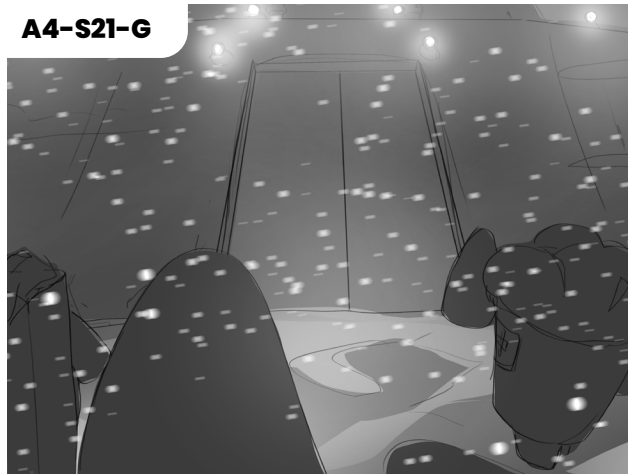

A4-S22-G

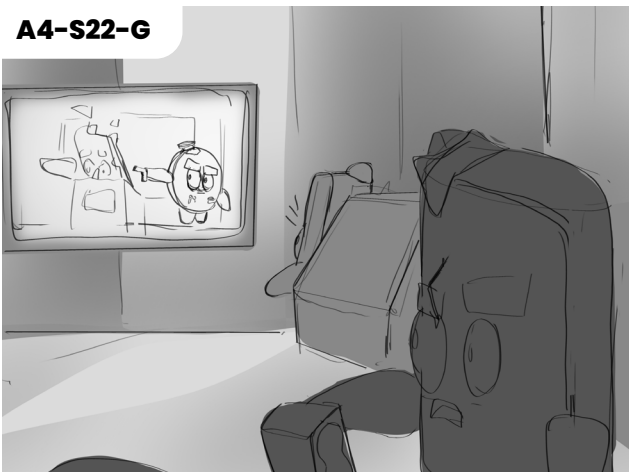

A4-S27-G

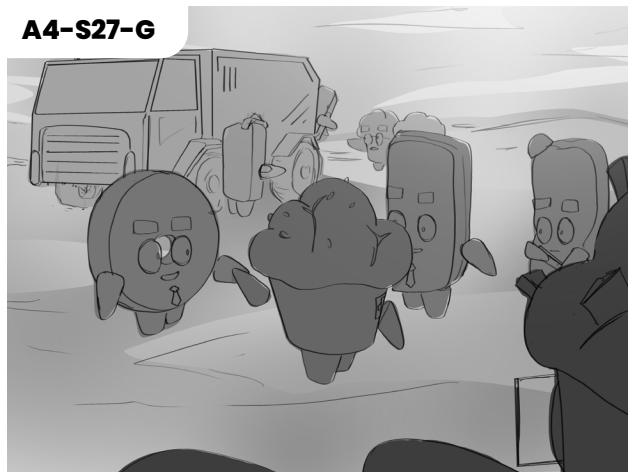

A4-S28-G



A4-S29-G



A4-S30-G

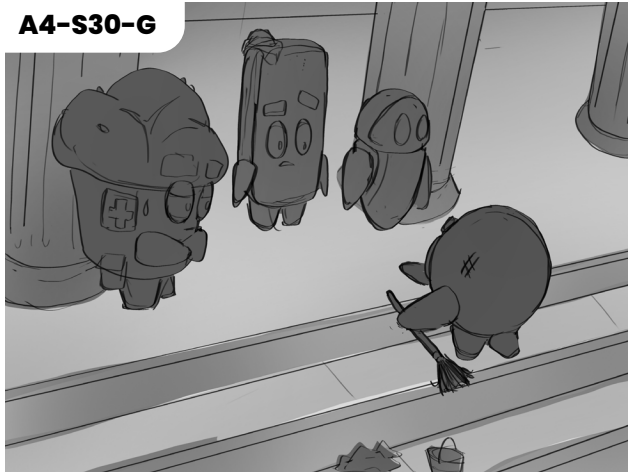

A4-S31-G

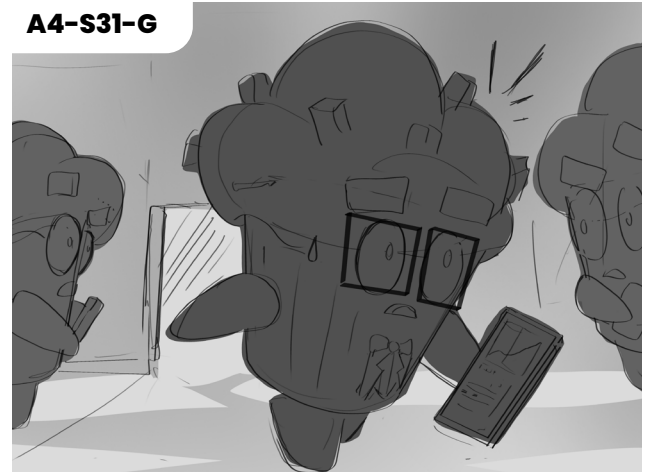

ACT 5.
"Good Path"

A5-S01-G

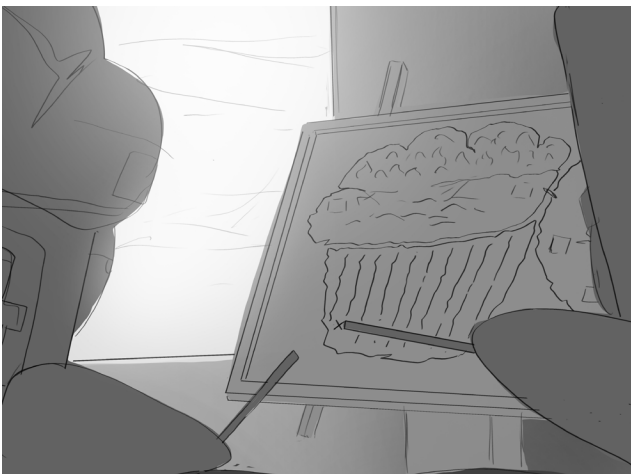
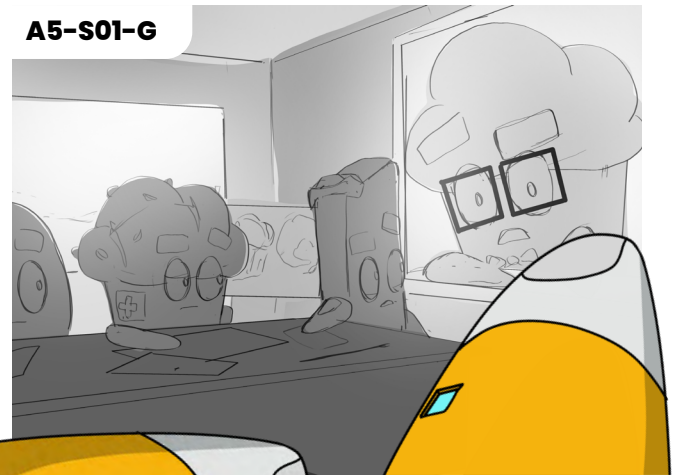

A5-S02-G

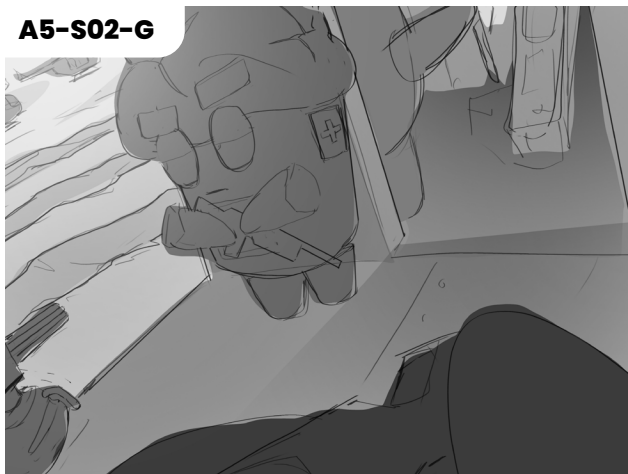

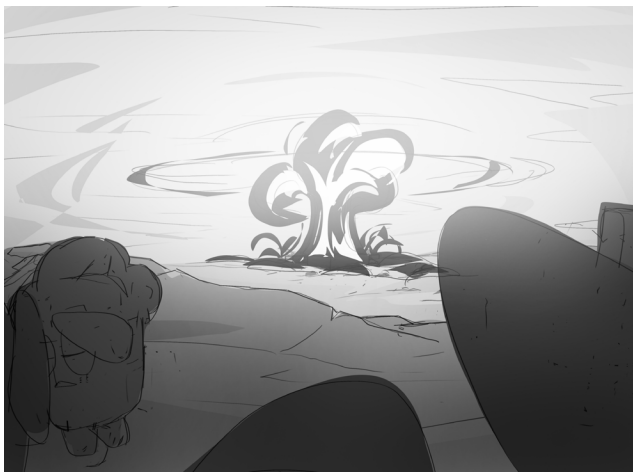
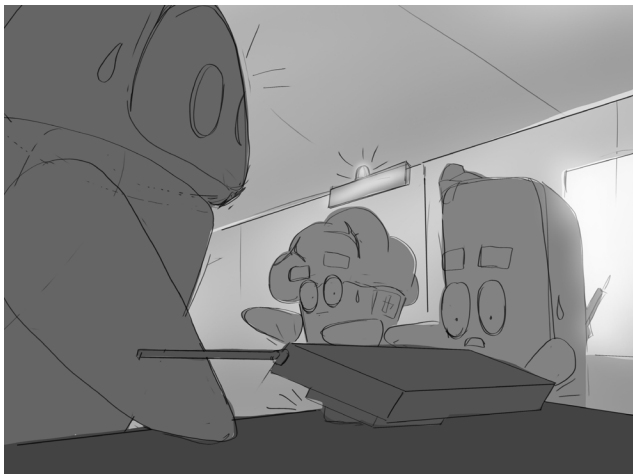
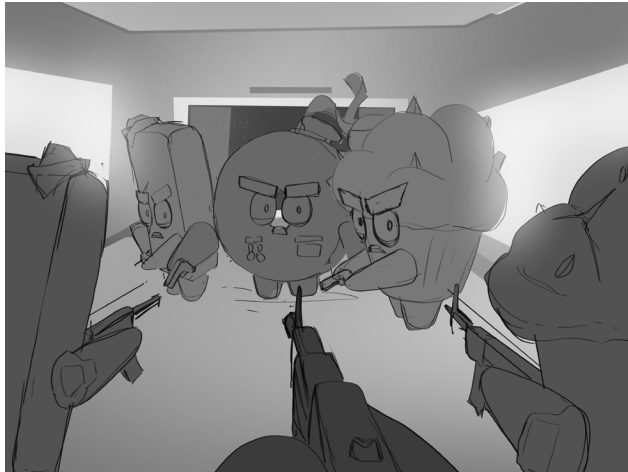

A5-S04-G

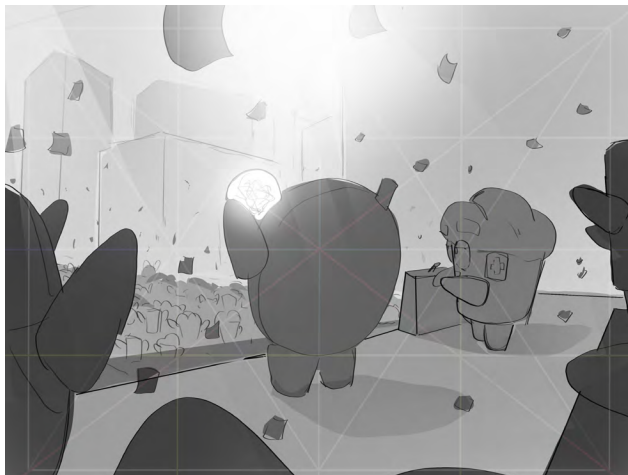
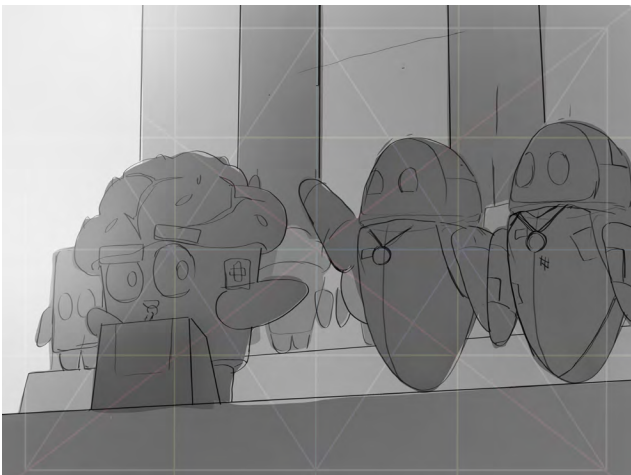
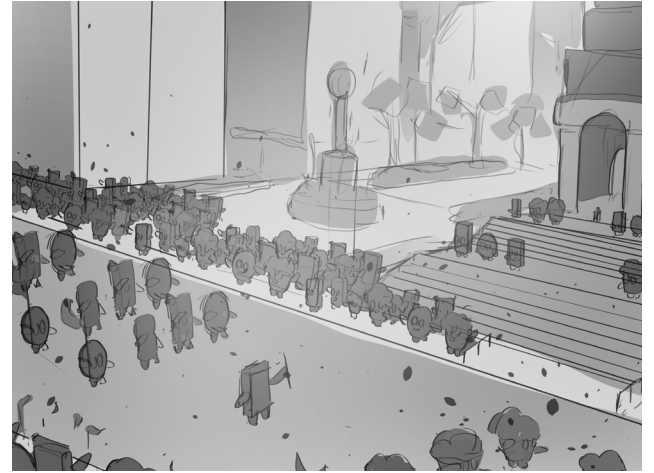
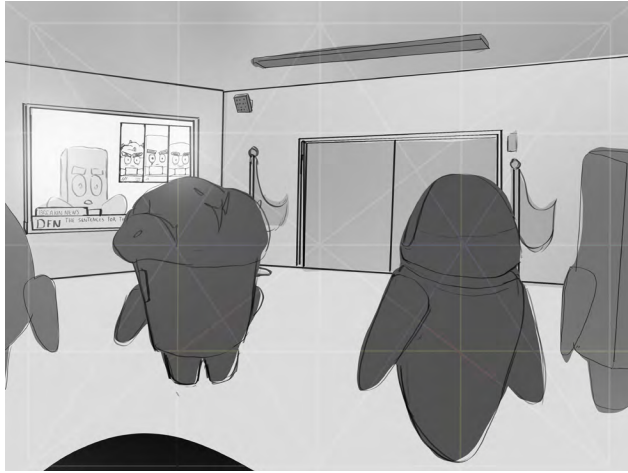
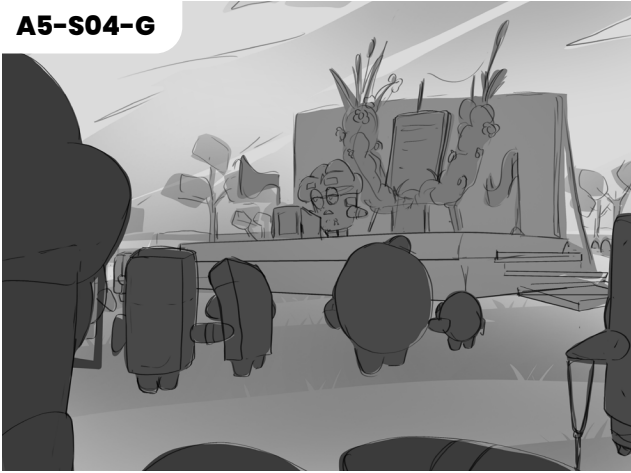

A4-S01-B

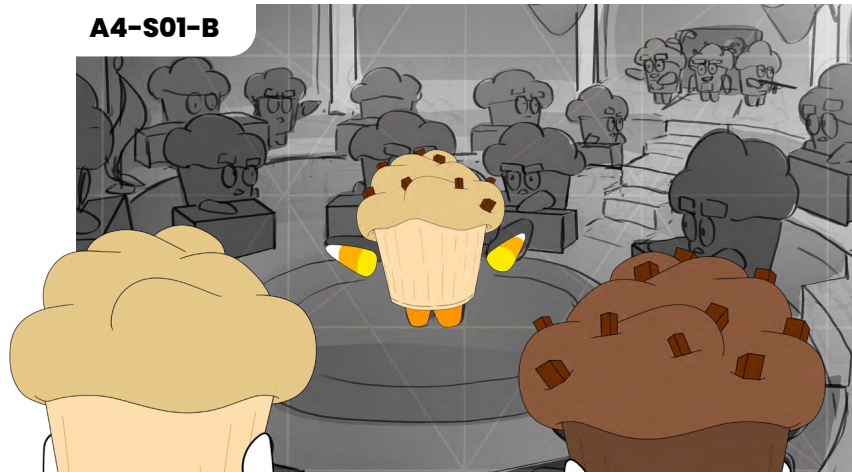

A4-S02-B



ACT 4.
"Bad Path"

A4-S03-B

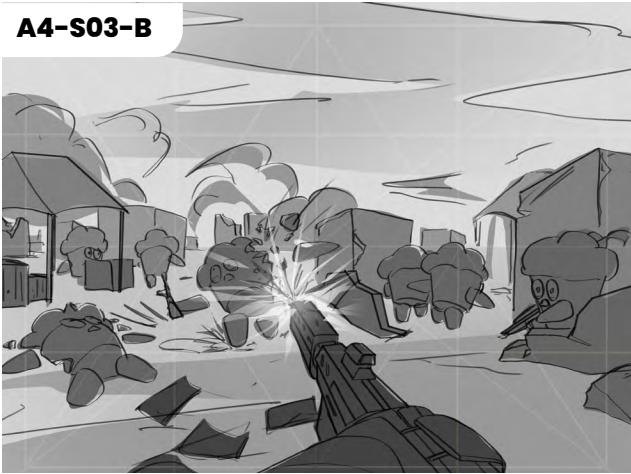

A4-S04-B

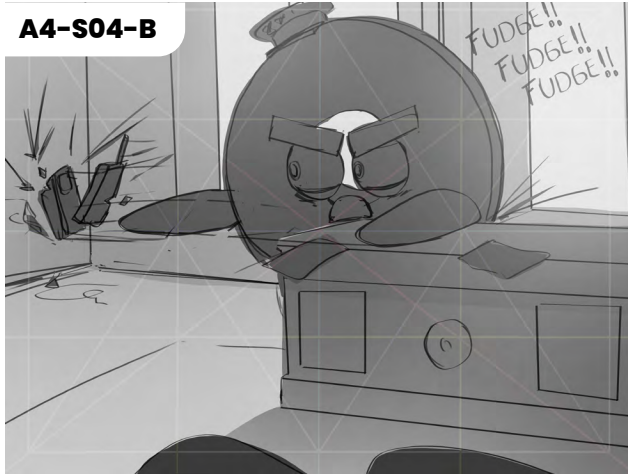

A4-S05-B

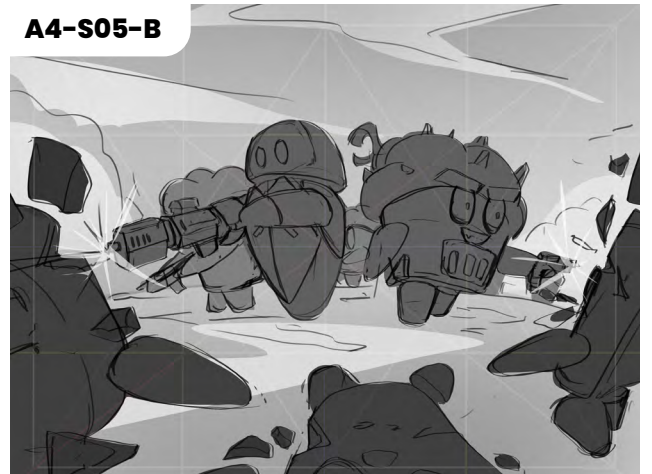

A4-S06-B

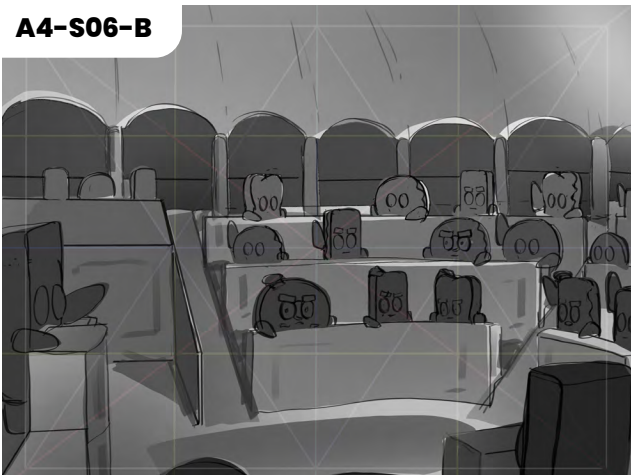

A4-S08-B

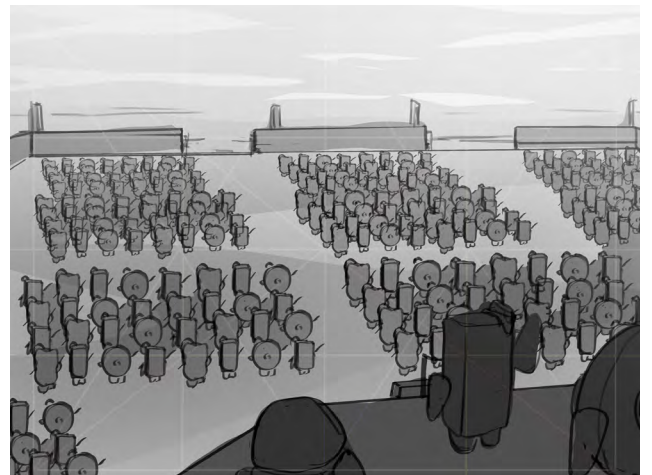
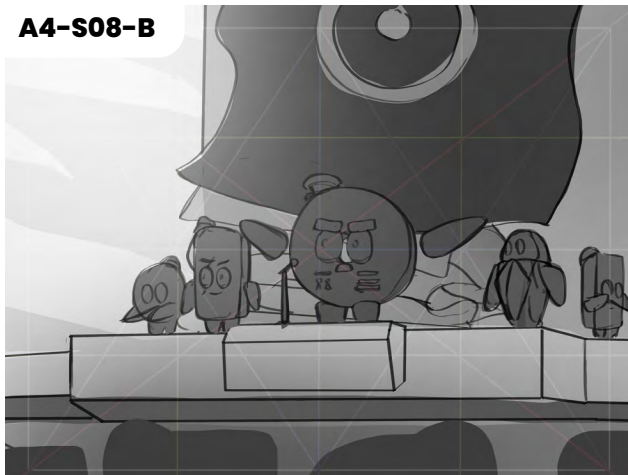

A4-S09-B



A4-S10-B

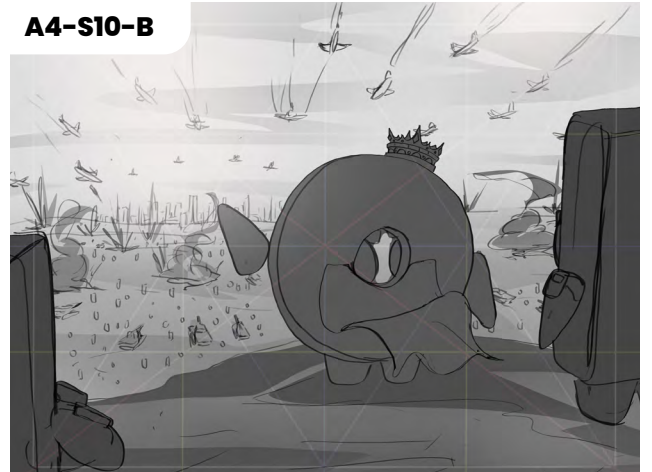

A4-S11-B



A4-S12-B

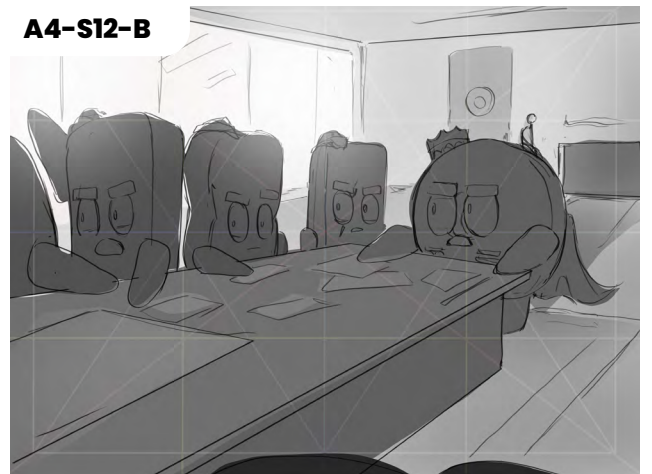

A4-S13-B

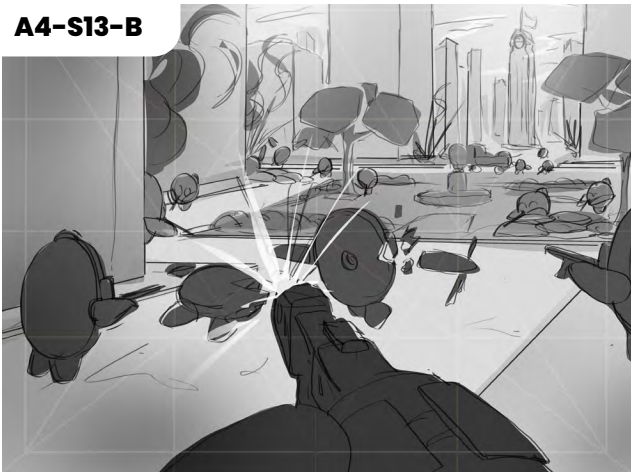

A4-S14-B

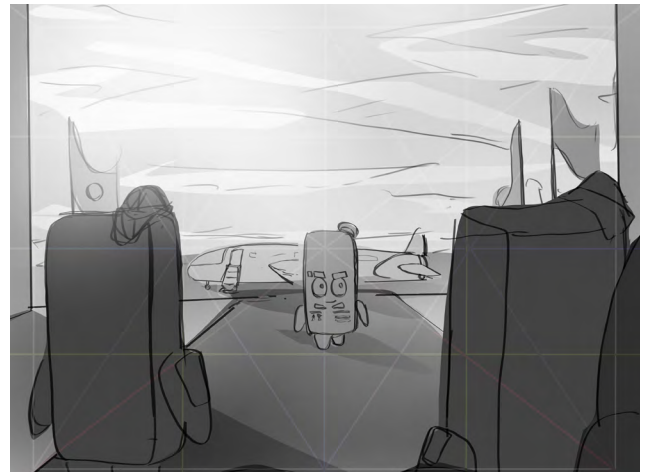
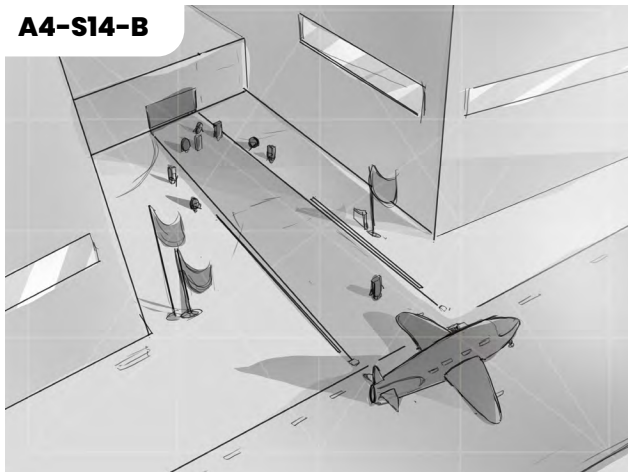

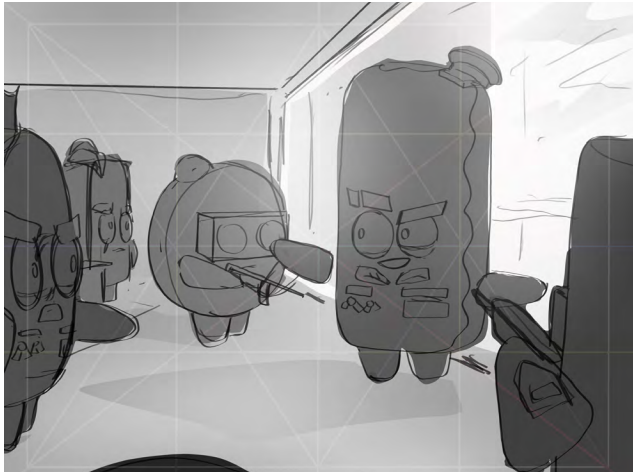

A4-S15-B

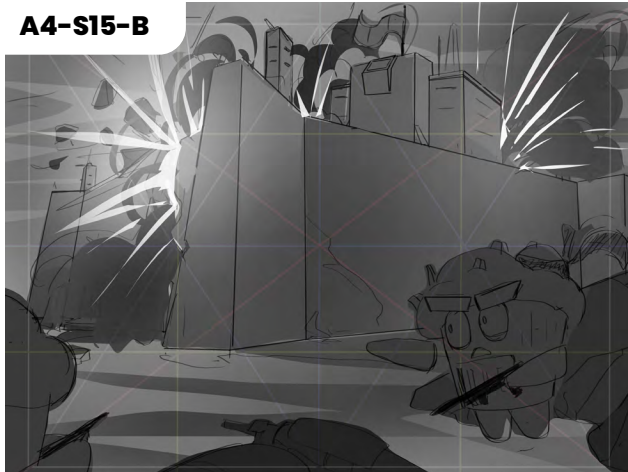

A4-S16-B

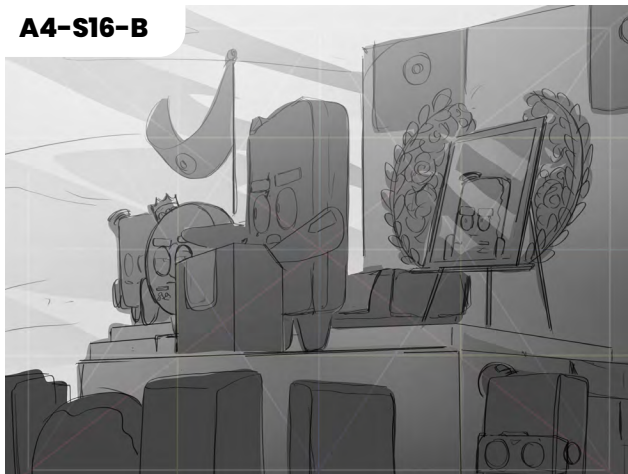

A4-S18-B

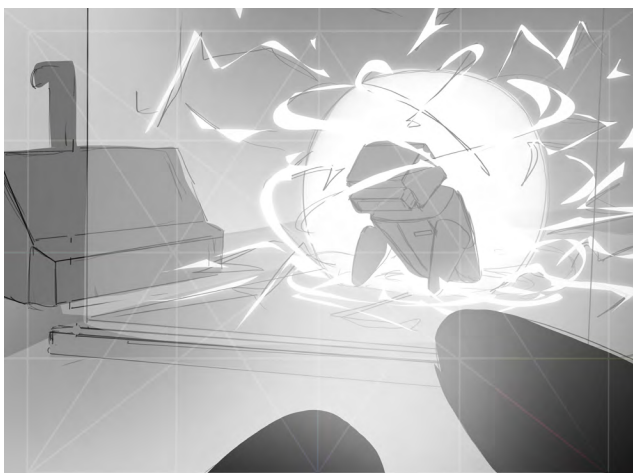
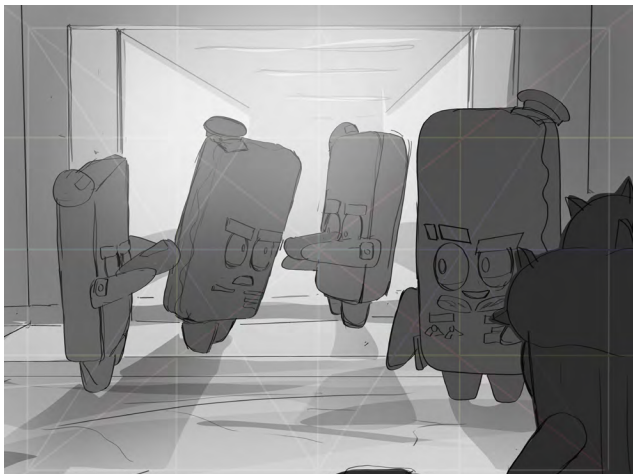
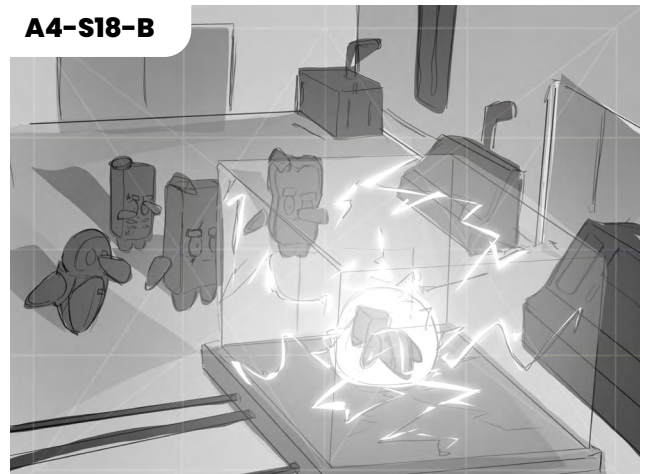

A4-S19-B

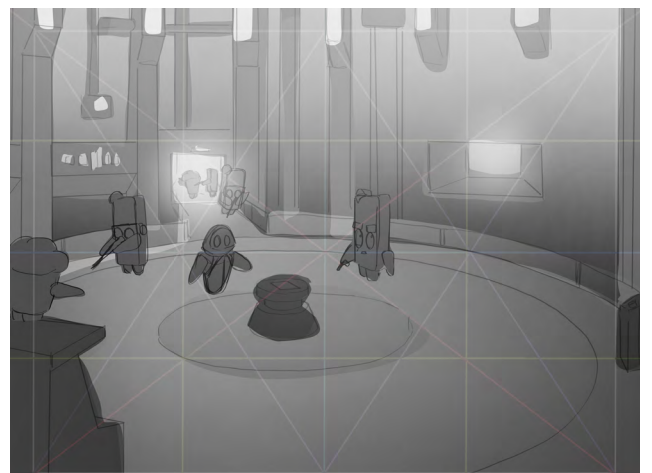
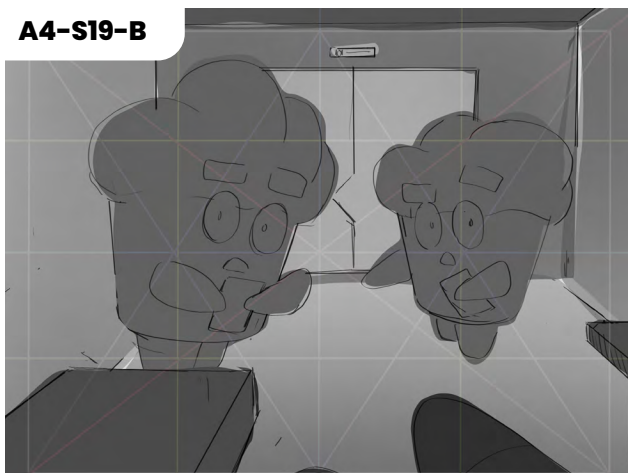

A4-S20-B



A4-S21-B

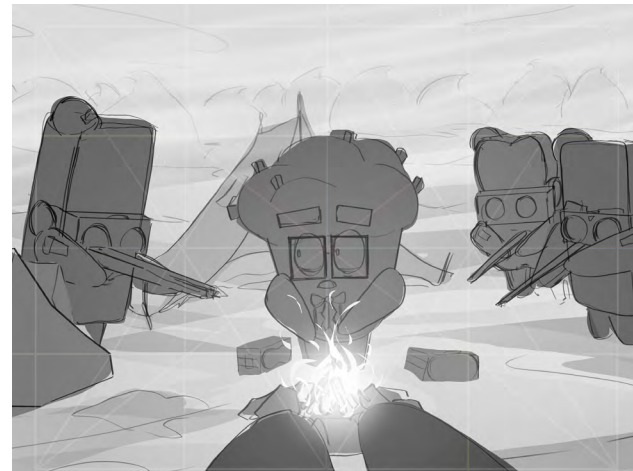

A4-S23-B

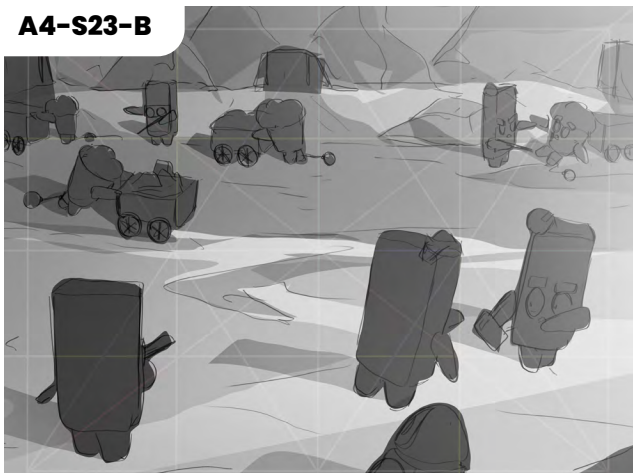

A4-S24-B

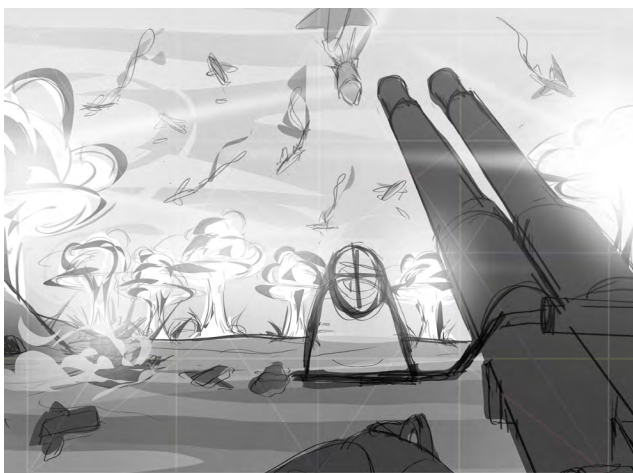
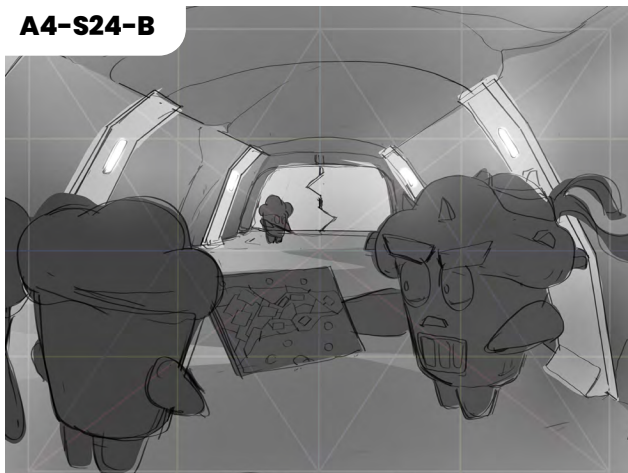

A4-S25-B

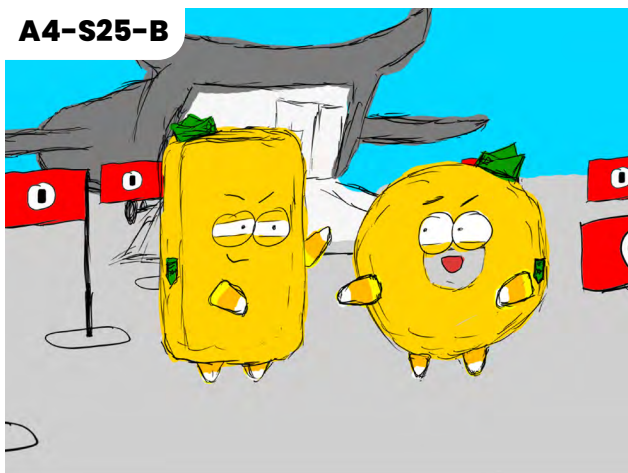



ACT 5.
"Bad Path"

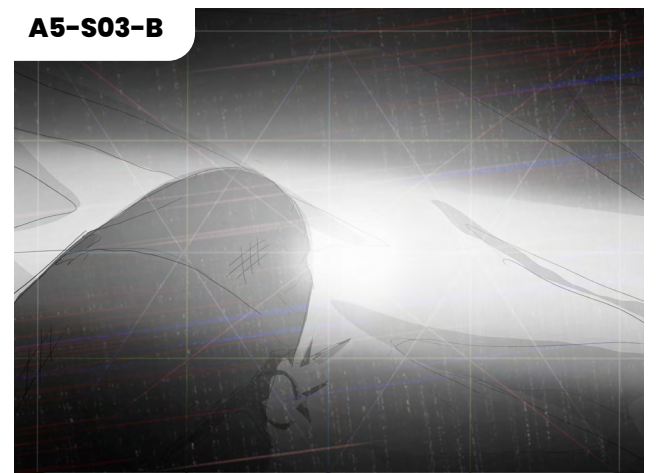
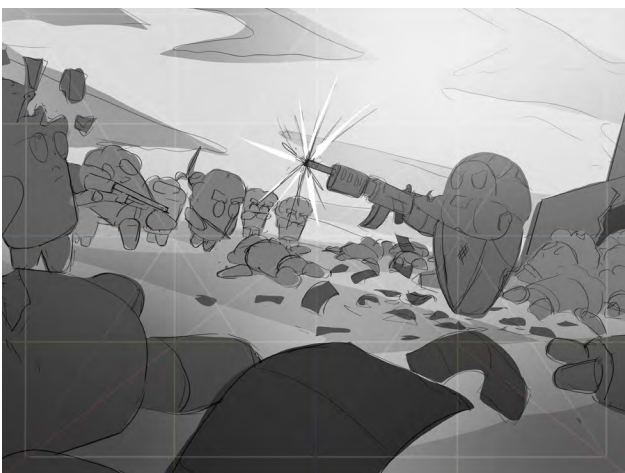
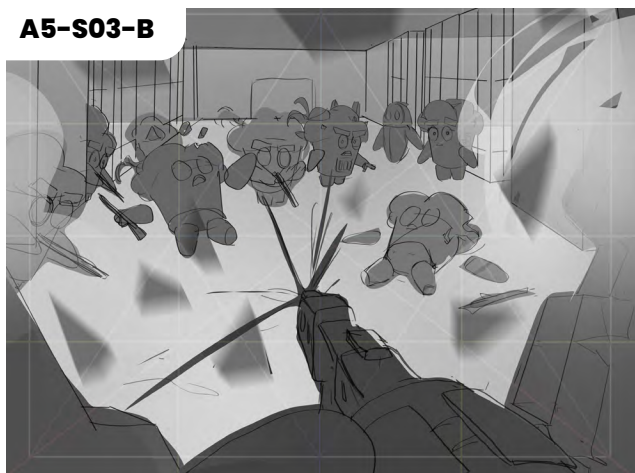
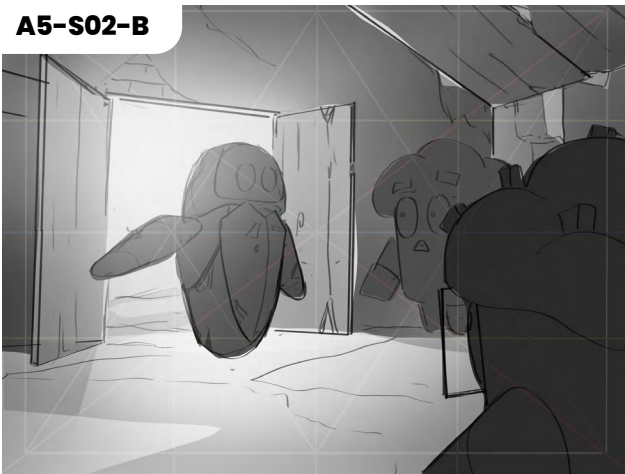
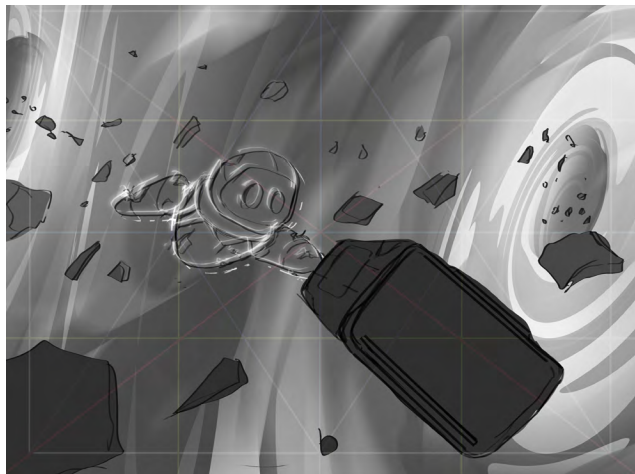

A5-S04-B

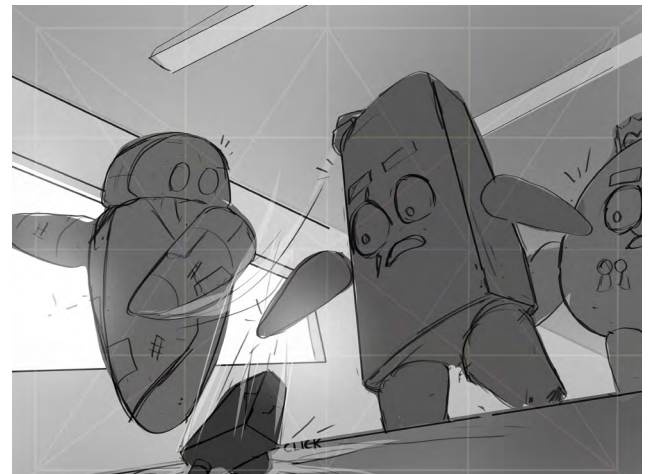
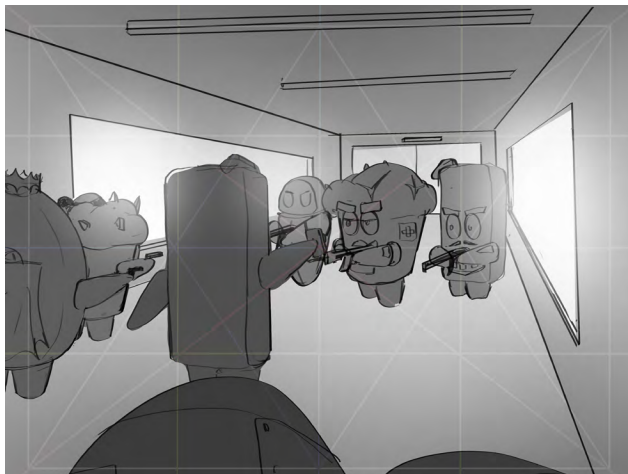
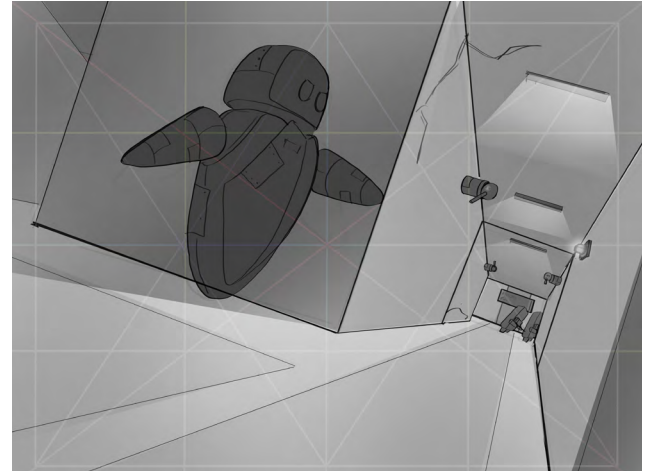
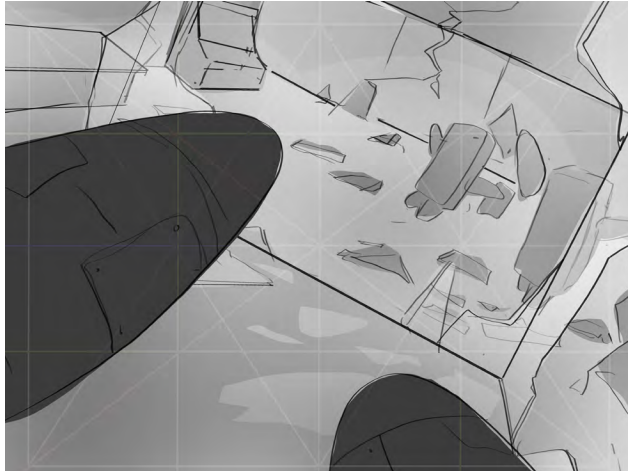
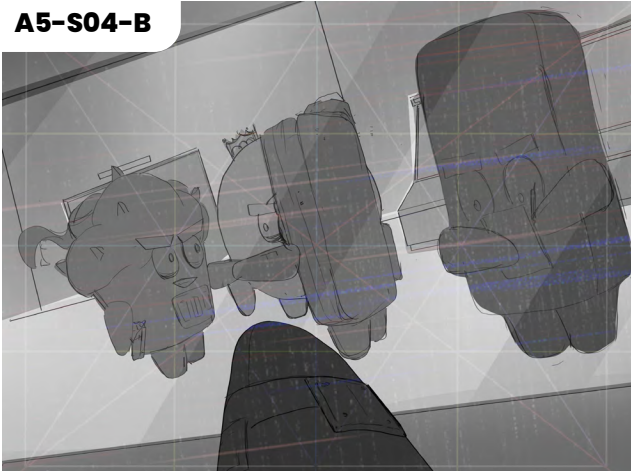

A5-S05-B

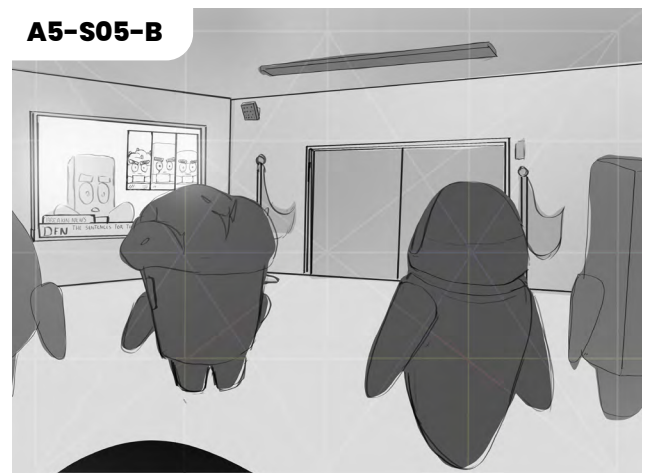

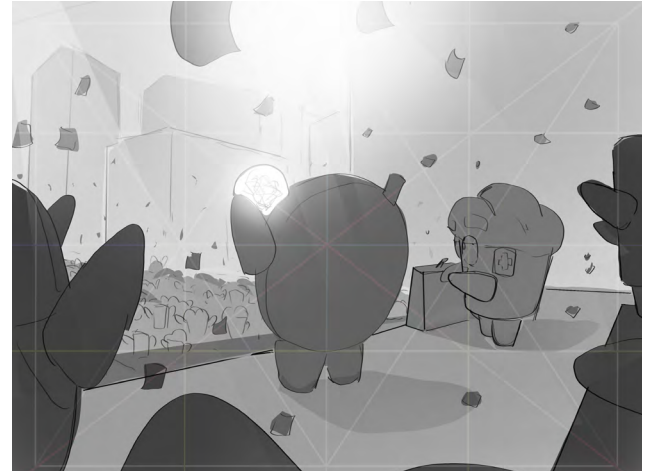
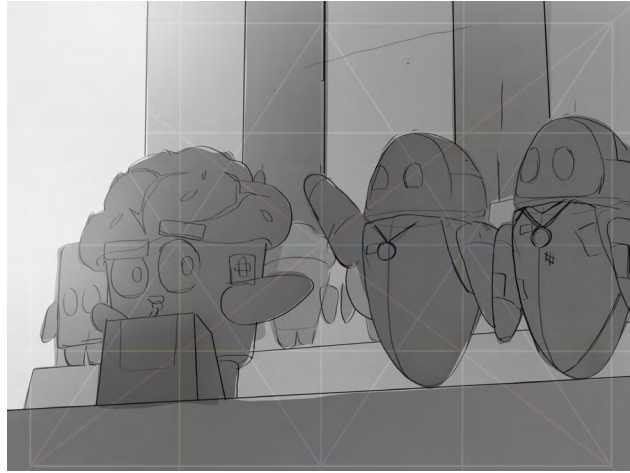
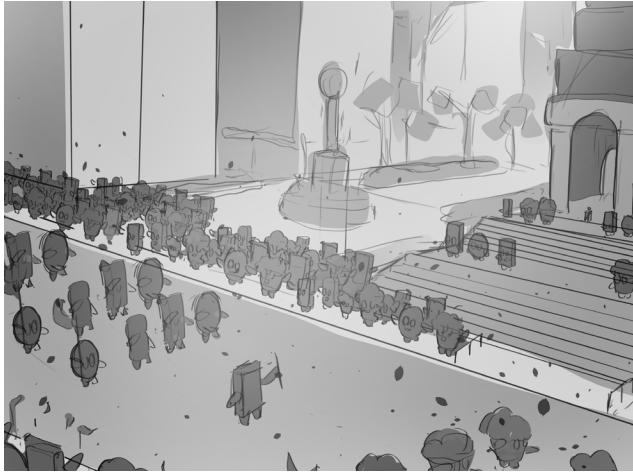

ANIMATIC
ACT 1 SCENE 5.

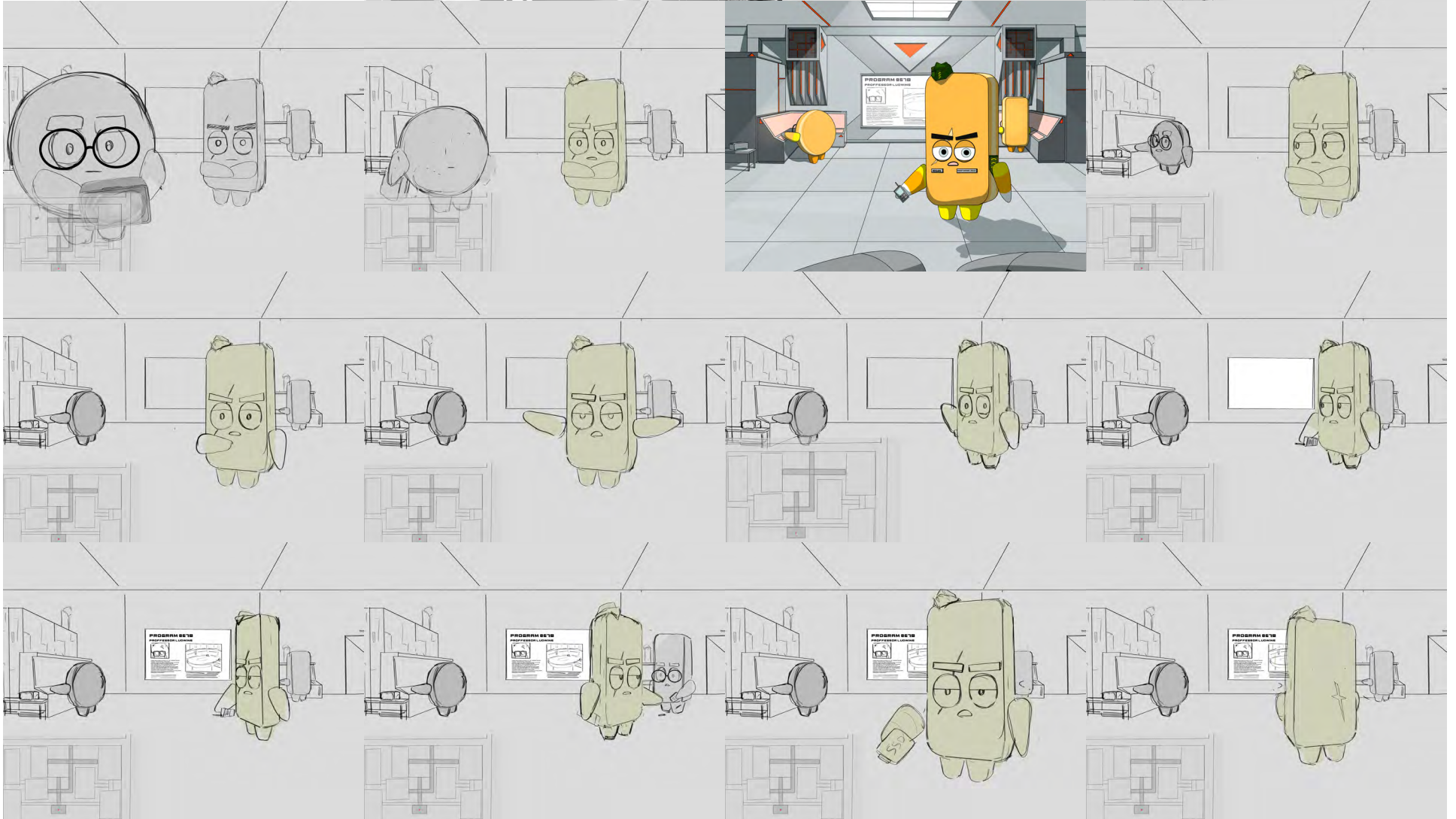
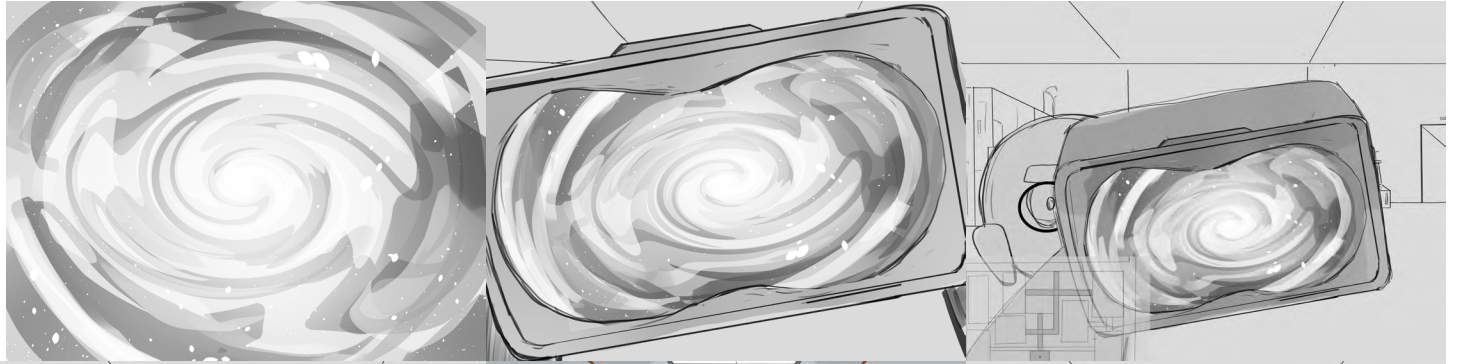

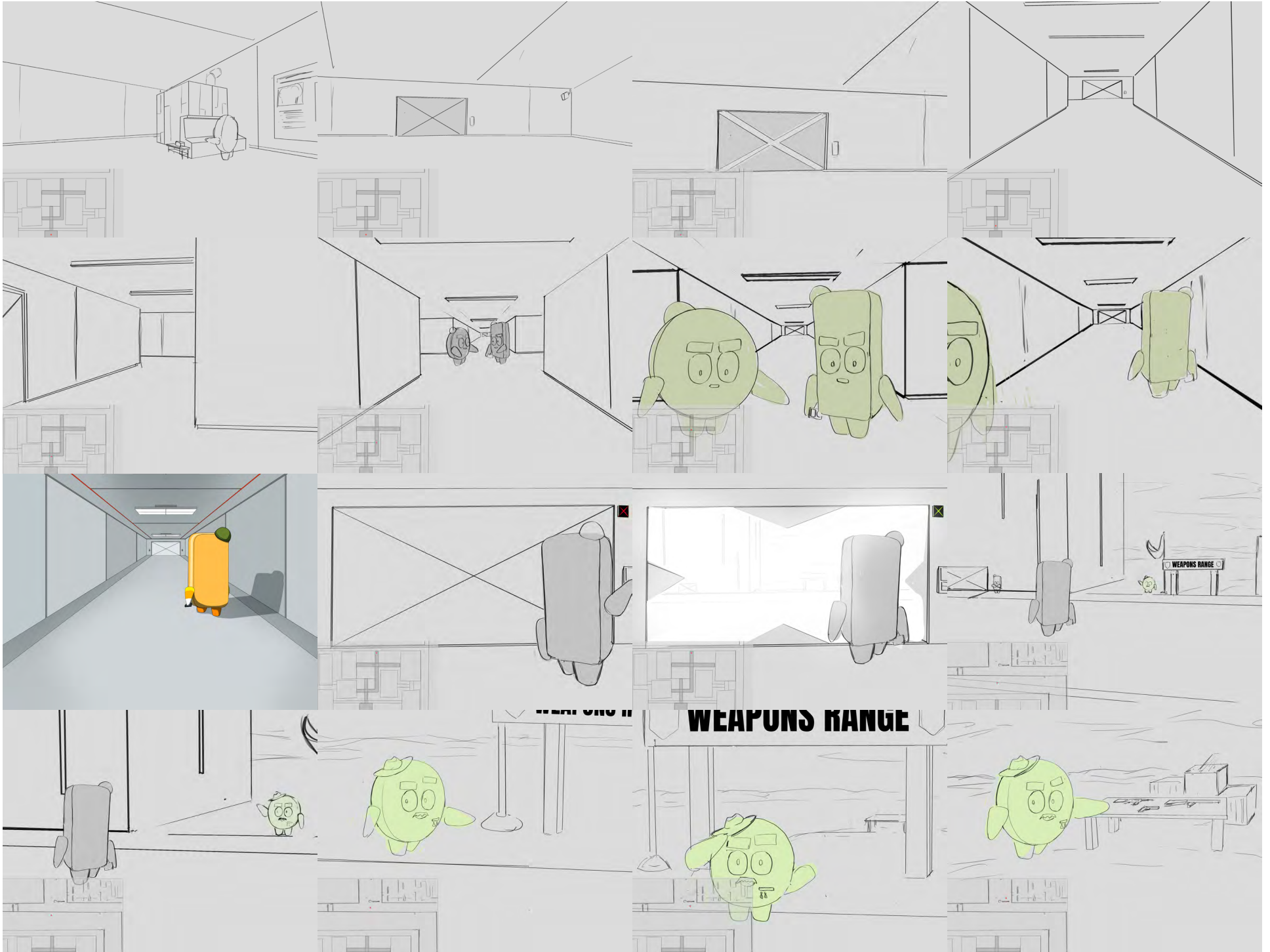

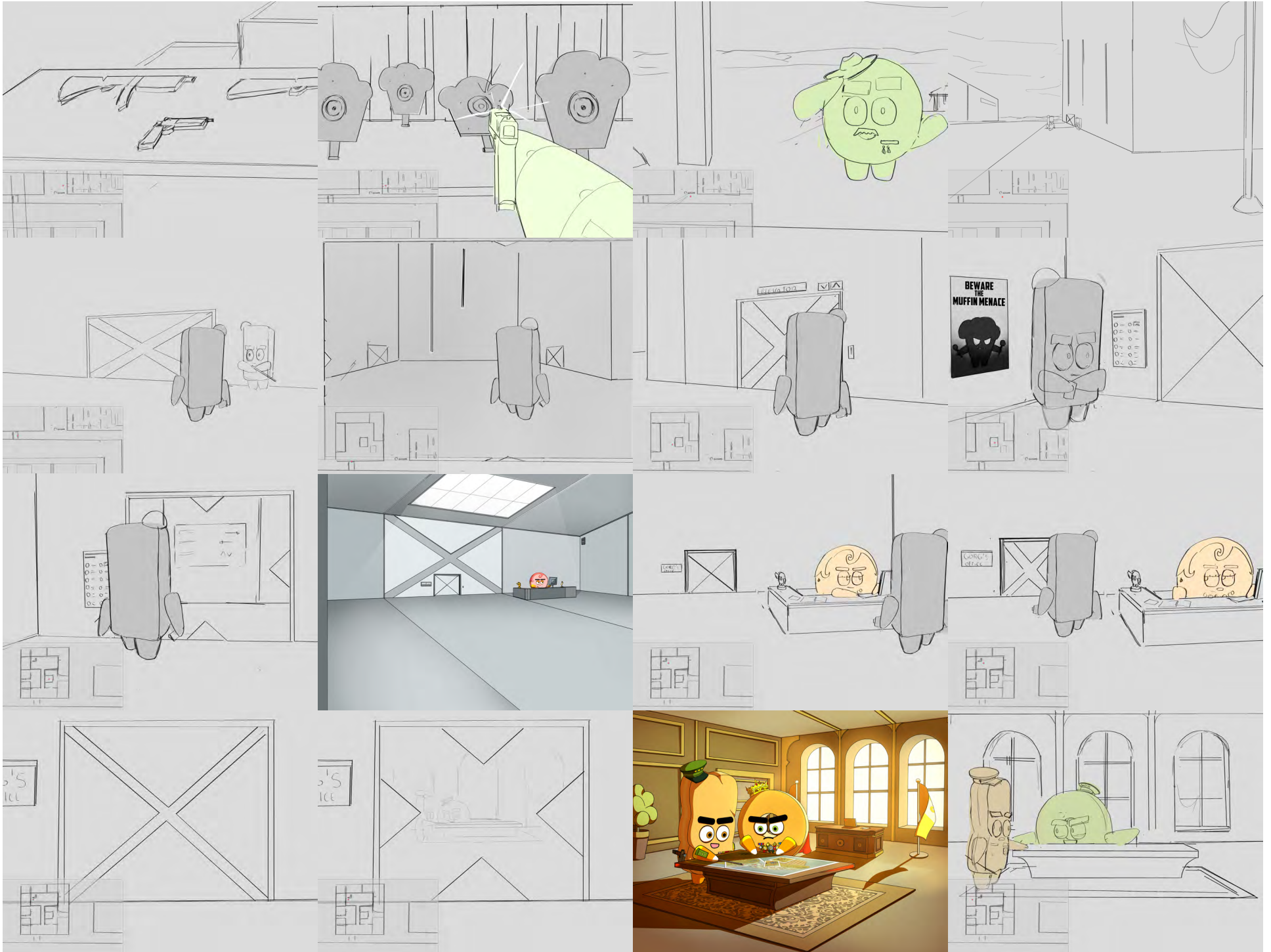

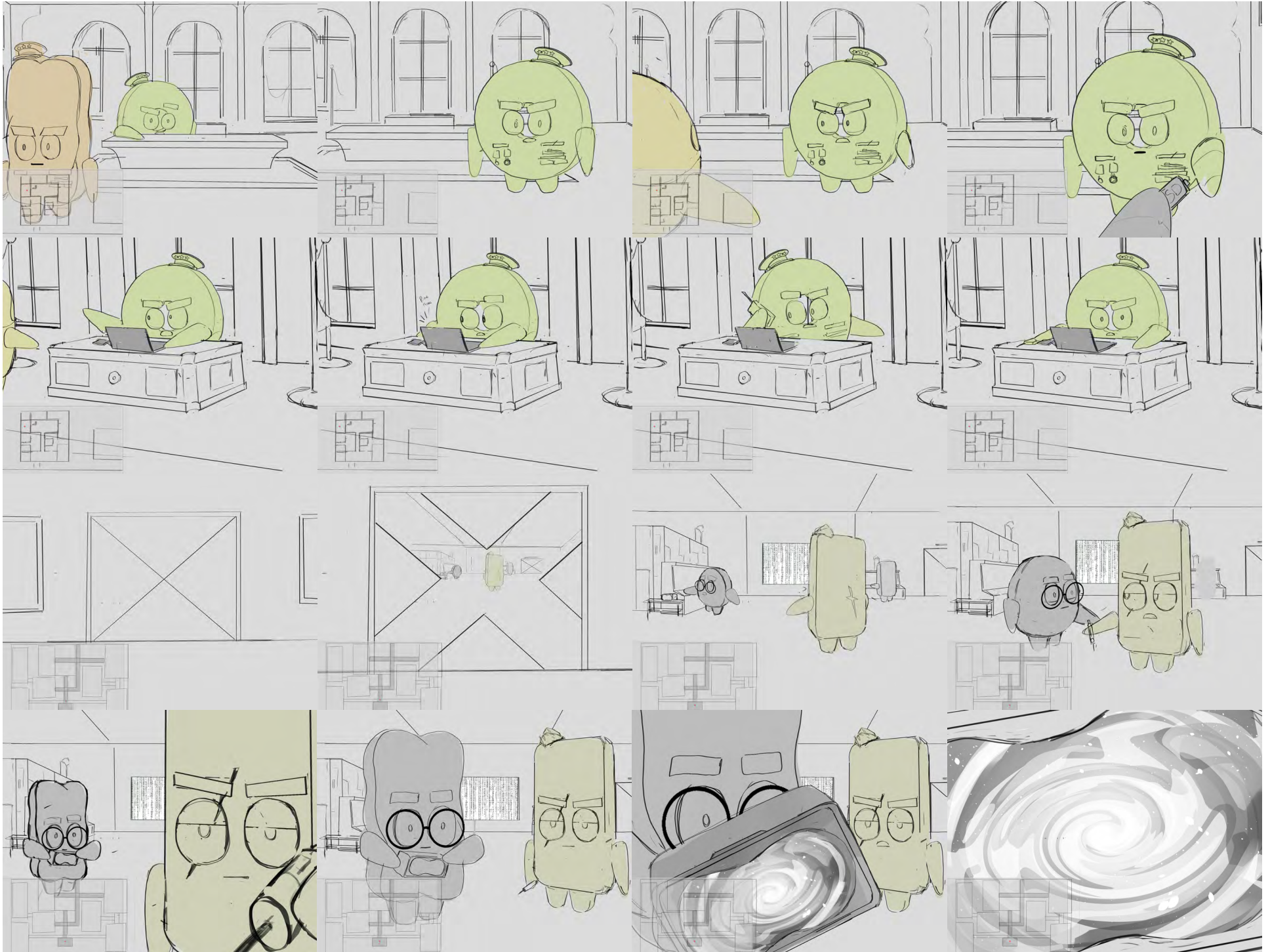

ANIMATIC
ACT 1 SCENE 6.



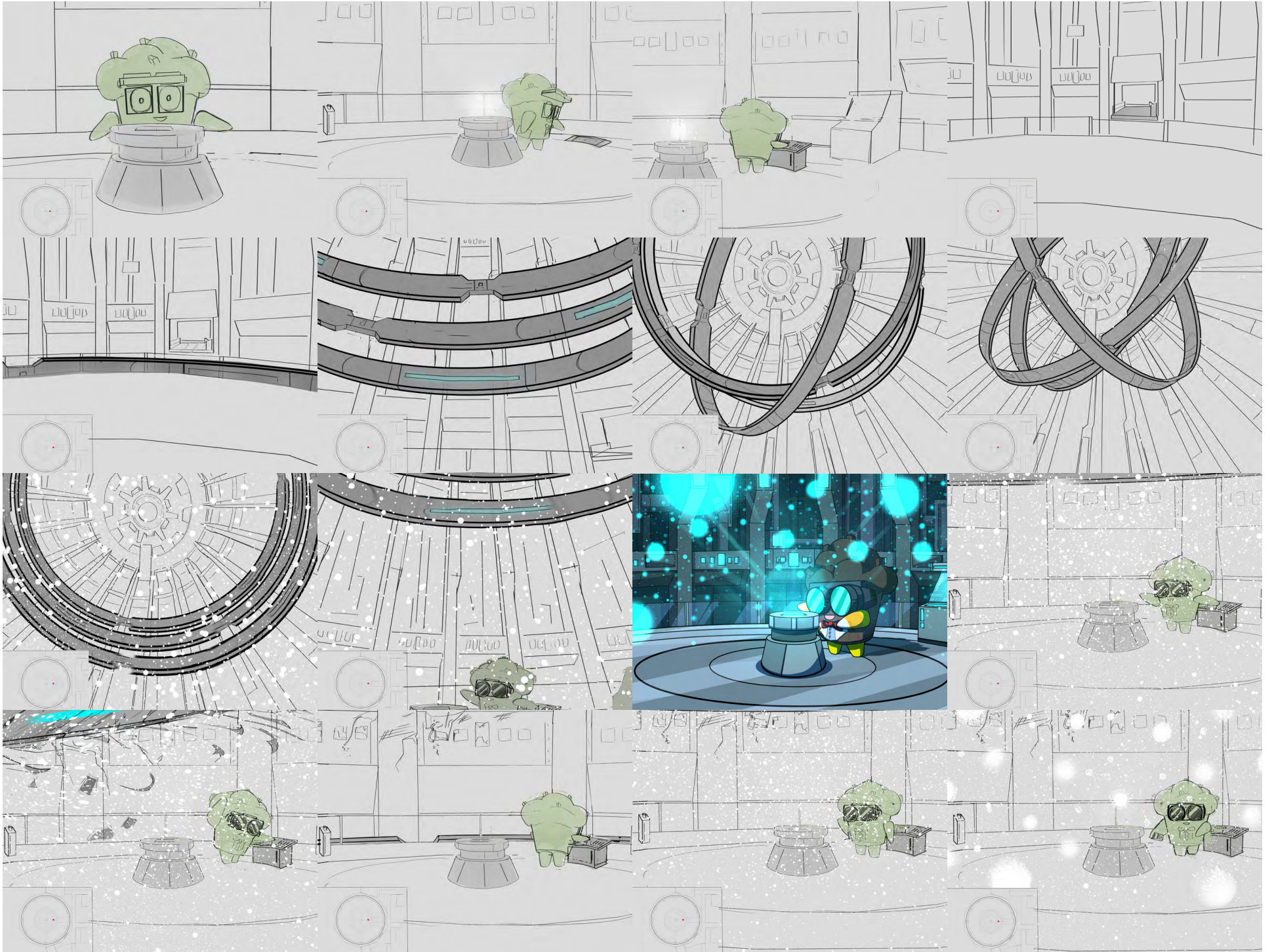







*"The best way to destroy an enemy
is to make him a friend."*

- Abraham Lincoln

CONCLUSION

In The Simulation™, we are not just building a game, but a world. A world filled with complexities, contrasting cultures, and unforgettable characters. A world that echoes the shades of our own, yet offers a distinct, immersive experience. The story we have crafted is not just of a war between Muffins and Donuts, but a tale of their struggles, their societies, and their individual characters, all set in a vivid and evolving environment.

We believe The Simulation™ is a game with immense potential. It combines unique narrative elements with innovative gameplay mechanics, setting the stage for an engaging and dynamic gaming experience. It provides players with a thought-provoking exploration of conflict, society, and individual agency, packaged within a world that blurs the lines between reality and simulation.

Our team is passionate, dedicated, and confident in our ability to bring this vision to life. But we understand that bringing The Simulation™ to its fullest potential is a collaborative effort. We are eager to work with new talented artists and industry leaders to help bring this game to players around the world.

***Thank you for your time and interest
in The Simulation™.***

The team behind The Simulation™ is small and highly focused. Each member contributes directly to the game's development, working closely to maintain a cohesive vision across story, design, art, and technology.

TEAM



Asim Deyaf
Creator

Hometown: Austin, Texas

Asim leads the creative direction of The Simulation™. He oversees game design, programming, narrative structure, and overall vision, guiding the project from concept through implementation.



Facundo Sosa (Haku)
2D Illustrator & Concept Artist

Hometown: Cordoba, Argentina

Haku defines the visual identity of The Simulation™ through concept art, illustration, and character design. His work establishes the tone, style, and personality of the game's world and characters.



Kurnia Indra
3D Artist

Hometown: Bandung, Indonesia

Kurnia creates 3D characters and assets, translating 2D concepts into optimized models designed to meet the performance demands of VR.



Amarchand Khorwal
Animator

Hometown: Rajasthan, India

Amar is a 2D and 3D animator with extensive experience across games, animation, and VR. He specializes in rigging and animation, contributing character motion and technical animation support throughout the project.



Ali Ayyaz
Producer

Hometown: Likes jumping time zones frequently

Ali oversees production and coordination on The Simulation™. Drawing on his extensive experience across all stages of game production, he actively contributes to game design, documentation, and level design, ensuring ideas move smoothly from concept to implementation.



Brendan Hutchins
Lead Developer

Hometown: Frisco, TX

Brendan leads Unity development for The Simulation™. He brings experience from multiple VR projects and is responsible for implementing systems, gameplay, and technical foundations across the game.



Contributors

Angel Esparza — 3D Artist

Hadley McMillan — 3D Artist

Isak Söderström — 3D Artist

Majd Abdo — 3D Artist

Hope Samson — 3D Artist

Pardeep Jaipal — 3D Rigger

Anas Javed — 3D Artist

Note: If you've contributed to this project and we've missed crediting you, please reach out. We're committed to acknowledging everyone's hard work.

THE SIMULATION™ — Development Book
Copyright © 2026 VR Sim Labs LLC. All rights reserved

Book Design & Layout
Facundo Sosa (Haku)

TEAM

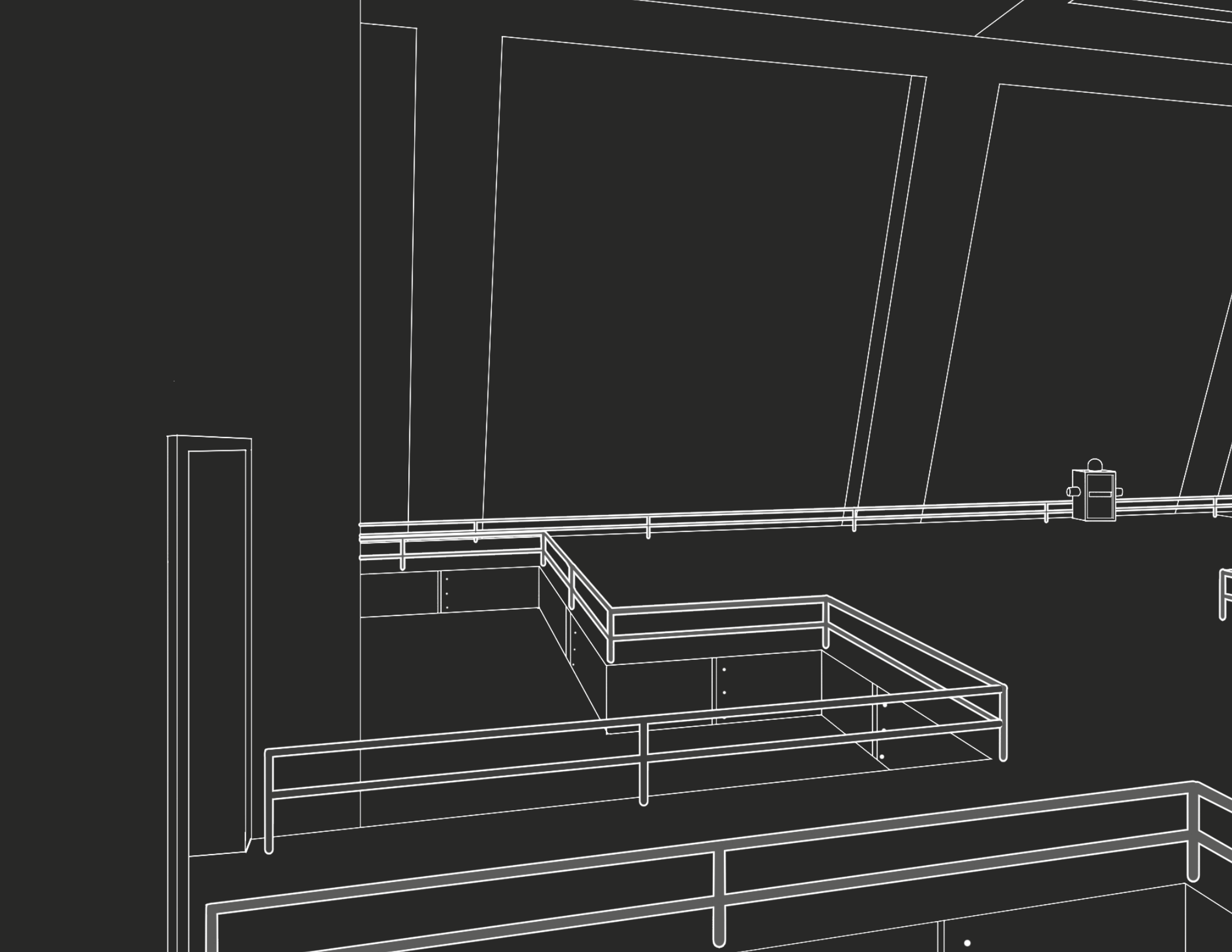

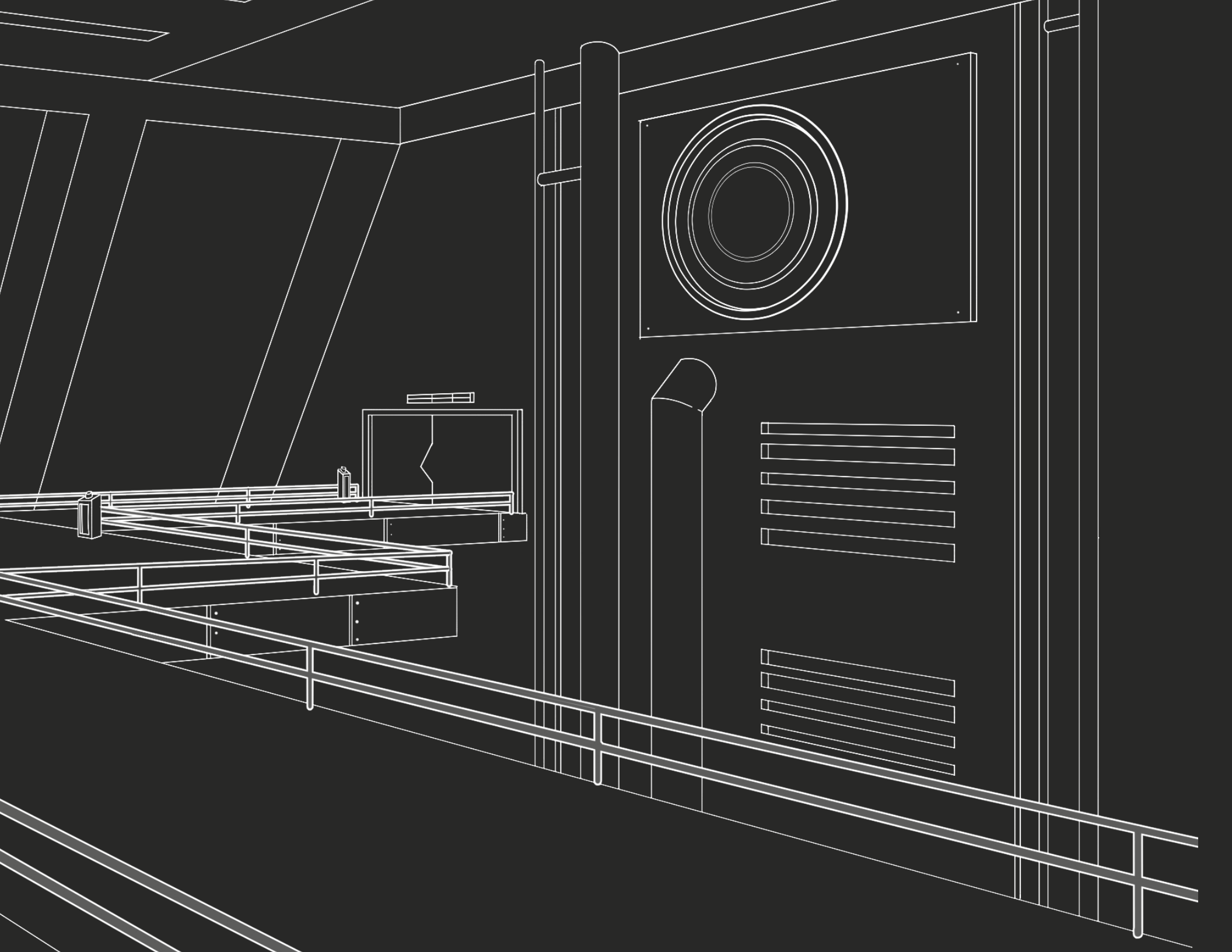



THE
SIMULATION™

© 2026 VR Sim Labs LLC. All rights reserved.

